

3 Pin XLR Male MIC Connector Nickel

PULSE



Specifications

No. of Contacts	: 3 Contacts
Gender	: Plug
Contact Resistance	: 3mΩ Max.
Insulator Resistance	: 5000MΩ Min.
Current Rating	: 3P/15A
Withstand Voltage	: 1500V AC

Diagram

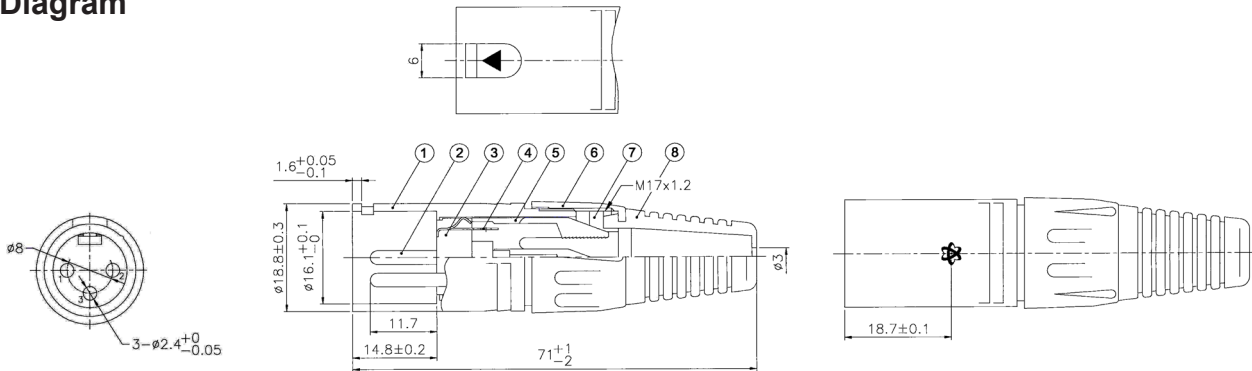

No.	Description	Material	Finish	Qty.
1	Die-Cast Shell	ZZnAL4-0	Nickel	1
2	Pin	H59-1	Silver	3
3	Insulator	PBT	Black	1
4	Terminal	H62	Tin	
5	Chuck	PA	White	
6	CAP	ZZnAL4-0	Black	
7	T-Ring	PP	White	
8	Boot	PVC	Black	

Part Number Table

Description	Part Number
3 Pin XLR Male Mic Connector, Nickel	PLS00214

Dimensions : Millimetres

Important Notice : This data sheet and its contents (the "Information") belong to the members of the AVNET group of companies (the "Group") or are licensed to it. No licence is granted for the use of it other than for information purposes in connection with the products to which it relates. No licence of any intellectual property rights is granted. The Information is subject to change without notice and replaces all data sheets previously supplied. The Information supplied is believed to be accurate but the Group assumes no responsibility for its accuracy or completeness, any error in or omission from it or for any use made of it. Users of this data sheet should check for themselves the Information and the suitability of the products for their purpose and not make any assumptions based on information included or omitted. Liability for loss or damage resulting from any reliance on the Information or use of it (including liability resulting from negligence or where the Group was aware of the possibility of such loss or damage arising) is excluded. This will not operate to limit or restrict the Group's liability for death or personal injury resulting from its negligence. PULSE is the registered trademark of Premier Farnell Limited 2019.

Newark.com/b/Pulse
Farnell.com/b/Pulse
sg.element14.com/b/pulse

PULSE