

Lieferzustand:
delivery condition:

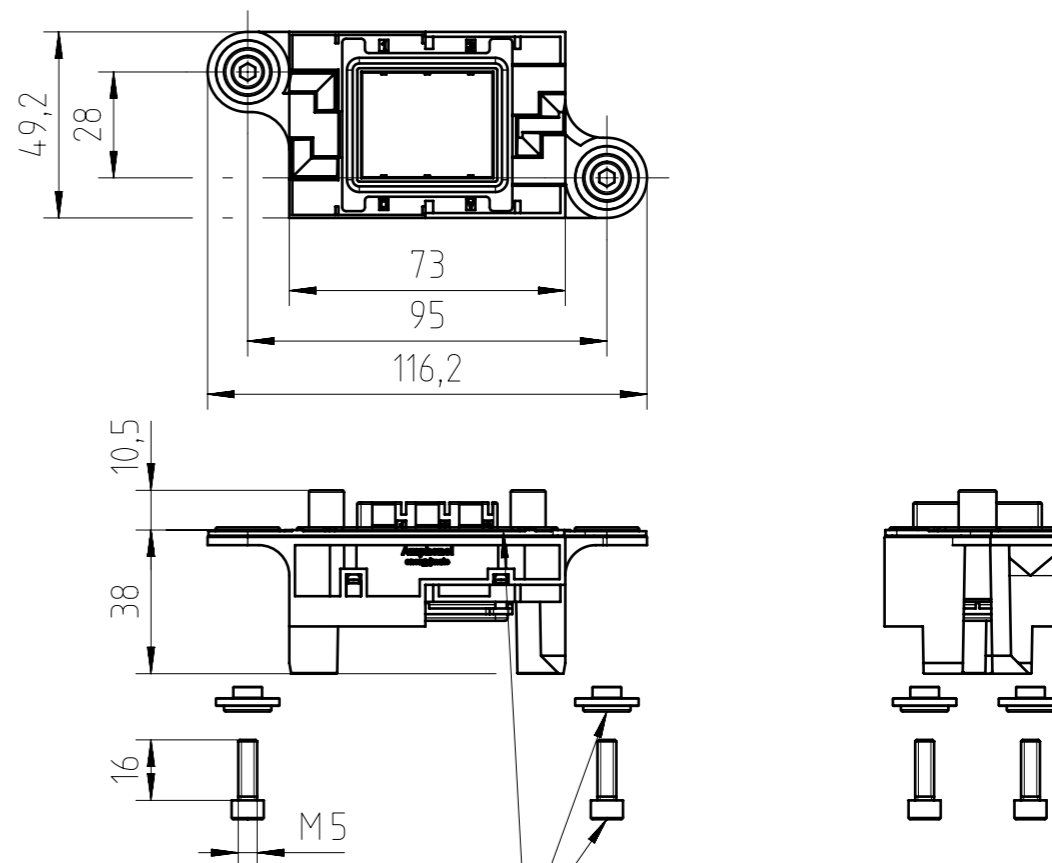

Schrauben, Scheiben und Dichtung lose beigelegt
bolts, washers and sealing attached loose

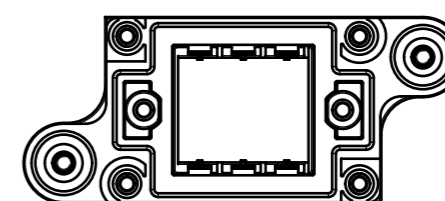

Hinweise zum Einbau siehe Seite 2
information for assembly see page 2

General Characteristics	Standard	Value
size		3 modules
tolerance compensation		both connectors floating: ±5mm one con. fix, other con. floating: ±2,5mm both connectors fixed: ±0mm
guiding range (suitable design of customers' devices to allow movement required)		one con. fix, other con. floating: up to ±7,5mm both connectors fixed: up to ±10mm
panel cut out		see page 2
protection class	IEC 60529	IP68 / IP69K (in mated condition)
Climatical Characteristics	Standard	Value
climatic category	IEC 60068-1	40 / 125 / 21
upper temperature	IEC 60512-11-9	+125°C
lower temperature	IEC 60512-11-10	-40°C
Mechanical Characteristics	Standard	Value
mechanical operation	IEC 60512-9-1	≥500 mating cycles
Materials	Standard	Value
module frame		PA-GF
flammability	UL 94	V-0
floating washers		steel Ni-plated
M5 bolts		steel Zn-plated
sealings		NBR

Alle technischen Daten wurden unter Laborbedingungen ermittelt und können im Praxisbetrieb abweichen. Es handelt sich bei den Angaben weder um Beschaffenheits- noch um Haltbarkeitsgarantien. Beim Gebrauch von Fremdkontakten wird für abweichende Eigenschaften keine Haftung übernommen.
All technical data have been measured in a laboratory environment and can be different during practical usage of the product. Any product information is for descriptive usage only and not legally binding, particularly the information does not constitute or provide any legal guarantees ("Beschaffenheitsgarantie" or "Haltbarkeitsgarantie"). By using contacts from other manufacturers the liability of the part is not assumed.

Gewicht (errechnet) / Calc WT: 76,9 kg		Zul. Abw./Tolerances:		Maßstab / Scale: 1:2	A3	
Prüfmaß / Testdimension		ISO 2768-mH		CUSTOMER DRAWING		
Teileindex / Partindexnumber:		DIN / ISO 13715		energymate 3 Module		
Bagatelle change:		Gez. 10.12.2020		energymate 3 modules		
		Drawn PWOELFFLE				
		Status Released				
		Gepr. 16.12.2020				
		Checked MBERTSCH				
		Amphenol Tuchel Industrial GmbH		M C146 N23 002 G8		Blatt / Sheet 1
01	202000172	15.12.2020	PWÖLF			2 Bl.
Index	Änderung / Description	Datum / Date	Name	Ers. f. / Replacement for: M-SK 202000172 312		

Coping of this document and giving it to others and the use or communication of the contents thereof, are forbidden without express authority. Offenders are liable to the payment of damages. All rights are reserved in the event of the grant of a patent or the registration of the utility model or design.
 Weitergabe sowie Vervielfältigung dieser Unterlage, Verwertung und Mitteilung ihres Inhalts nicht gestattet, soweit nicht ausdrücklich zugestanden. Zuwiderhandlungen verpflichten zu Schadenersatz. Alle Rechte für den Fall der Patenterteilung oder Gebrauchsmuster-Eintragung vorbehalten.

FAI2020-004474
NXM-V01

Montageausschnitt feste Lagerung /
panel cut-out fixed assembly :

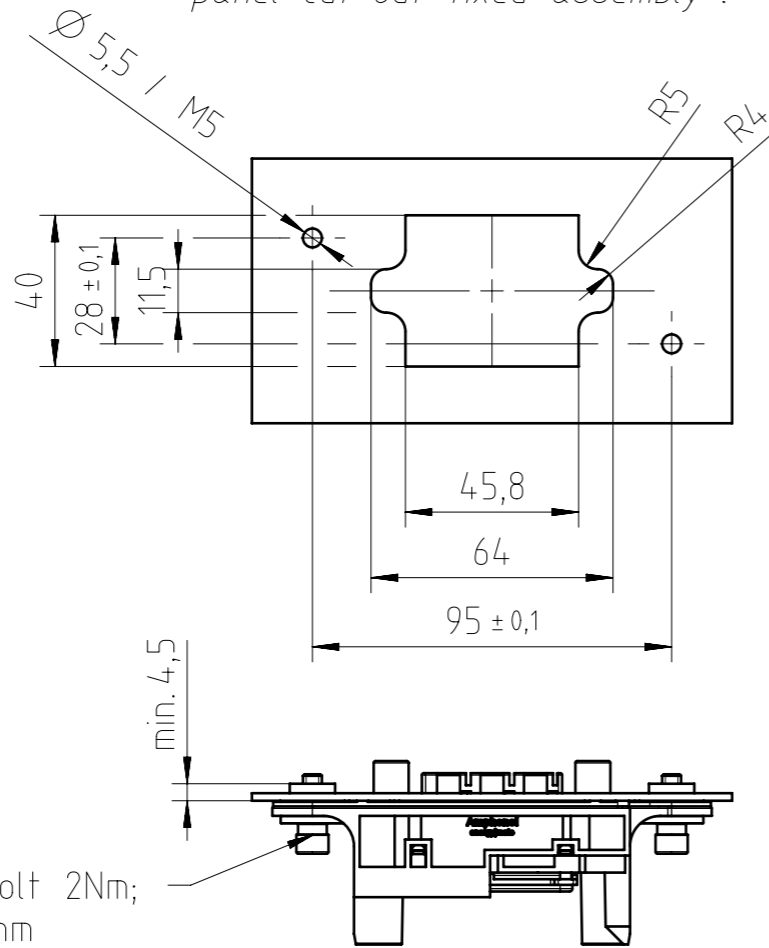

Anziehdrehmoment M5 bolt 2Nm;
Einschraubtiefe min 4,5mm
tightening torque M5 bolt 2Nm;
screw-in depth min. 4,5mm

Gesteckter Zustand /
mated condition :

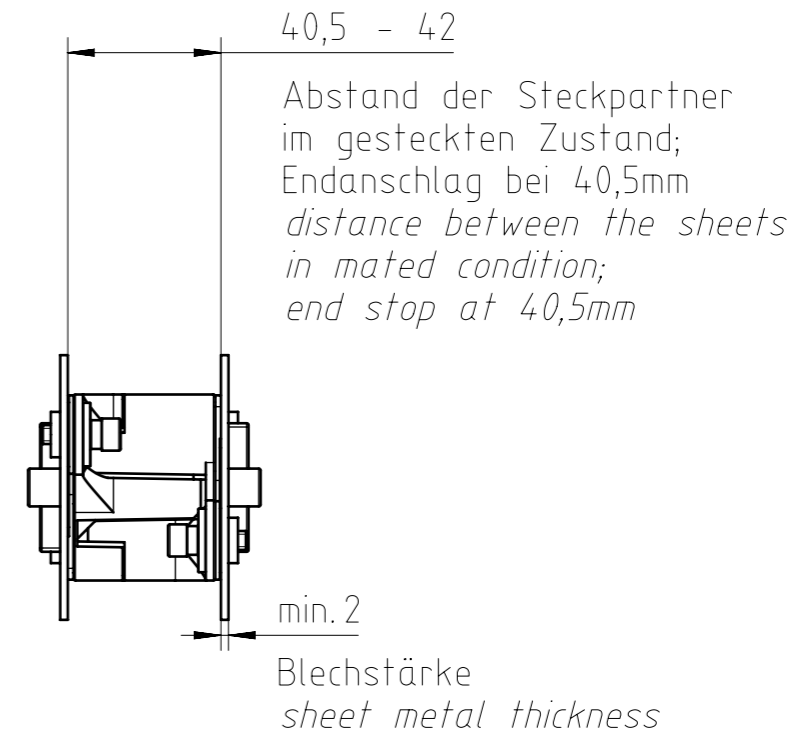

- Zugentlastung erforderlich um Kräfte durch die Verkabelung auf den Steckverbinder zu verhindern
- zulässige Materialien für Montageblech:
 - Stahl (Ø 5,5 + Stahl-Mutter / M5)
 - Al-Legierungen ausgehärtet (Ø 5,5 + Stahl-Mutter)
- Montageblech Ebenheit: 0,1
- strain-relief necessary to avoid cable forces to the connector
- approved materials for sheet metal:
 - steel (Ø 5,5 + steel hex nut / M5)
 - aluminium-alloys hardened (Ø 5,5 + steel hex nut)
- sheet metal flatness: 0,1

Gewicht (errechnet) / Calc WT: 76,9 kg		Zul. Abw./Tolerances:		Maßstab / Scale : 1:2	A3	
Prüfmaß / Testdimension		ISO 2768-mH		CUSTOMER DRAWING		
Teileindex / Partindexnumber:		DIN / ISO 13715		energymate 3 Module		
Bagatelle change:		Gez. 10.12.2020		energymate 3 modules		
		Drawn PWOELFFLE				
		Status Released				
		Gepr. 16.12.2020				
		Checked MBERTSCH				
		Amphenol Tuchel Industrial GmbH		M C146 N23 002 G8		Blatt / Sheet 2
01	202000172	15.12.2020	PWÖLF	Ers. f. / Replacement for : M-SK 202000172 312		2 Bl.
Index	Änderung / Description	Datum / Date	Name			

Copying of this document and giving it to others and the use or communication of the contents thereof, are forbidden without express authority. Offenders are liable to the payment of damages. All rights are reserved in the event of the grant of a patent or the registration of the utility model or design.

Weitergabe sowie Vervielfältigung dieser Unterlage, Verwertung und Mitteilung ihres Inhalts nicht gestattet, soweit nicht ausdrücklich zugestanden. Zuwiderhandlungen verpflichten zu Schadenersatz. Alle Rechte für den Fall der Patenterteilung oder Gebrauchsmuster-Eintragung vorbehalten.

FAI2020-004474