

For mating dimensions see MIL-DTL-38999 Series III

Reference MIL-STD-1560 for insert arrangement details. For non-MS arrangements consult Amphenol.

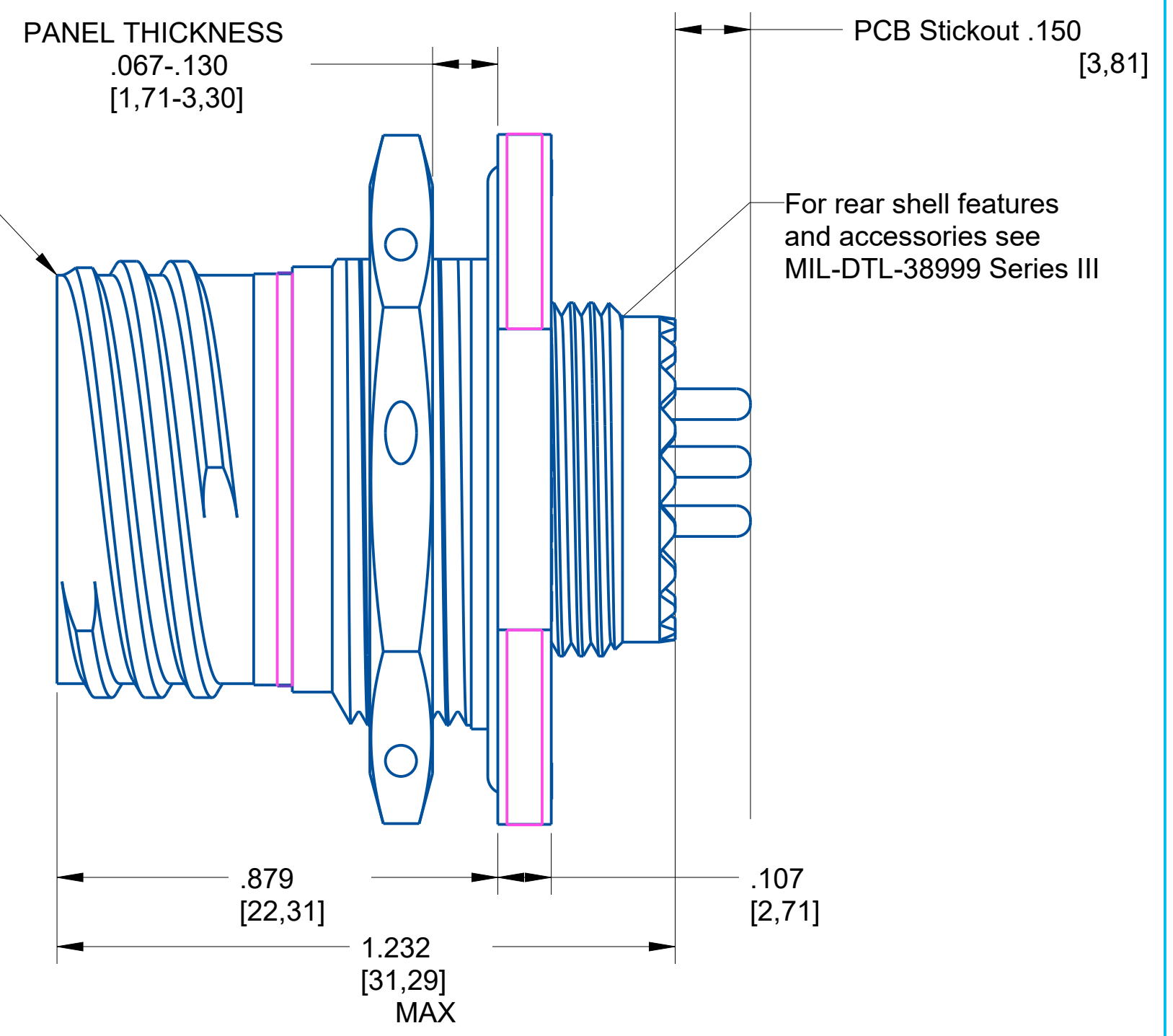

NOTE:
 -DRAWING NOT TO SCALE
 -DIMENSIONS SUBJECT TO CHANGE
 -DIMENSIONS ARE IN INCHES [MM]
 PROPERTY OF AMPHENOL AEROSPACE. ALL RIGHTS RESERVED.

Meets applicable requirements of MIL-DTL-38999
 Base Material: Aluminum
 Plating: AP-93

AMPHENOL CORPORATION <small>40-60 DELAWARE AVENUE SIDNEY, N.Y. 13838</small>			
RECEPTACLE Electrical Connector TVS07			U
SIZE C	CAGE CODE 77820	CODED NUMBER TVS07DS-13-4P(P15)	REV X1
SHEET 1 OF 1			

Insert Arrangement

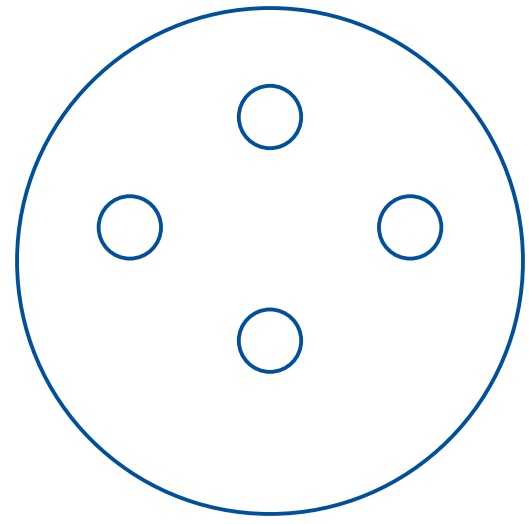

No. of Contacts	4
Contact Size	16
Wire Size	20, 18, 16

Shell Size	13
Arrangement	4
Service Rating	I
Test Current	13 AMPS

NOTE:
 -DRAWING NOT TO SCALE
 -DIMENSIONS SUBJECT TO CHANGE
 -DIMENSIONS ARE IN INCHES [MM]

PROPERTY OF AMPHENOL AEROSPACE. ALL RIGHTS RESERVED.

AMPHENOL CORPORATION <small>40-60 DELAWARE AVENUE SIDNEY, N.Y. 13838</small>			
RECEPTACLE Electrical Connector TVS07			U
<small>SIZE</small> C	<small>CAGE CODE</small> 77820	<small>CODED NUMBER</small> TVS07DS-13-4P(P15)	<small>REV</small> X1
SHEET 1 OF 1			