

QUINT4-UPS/1AC/1AC/500VA/USB

Uninterruptible power supply

Data sheet
108985_en_00

© PHOENIX CONTACT 2020-09-09



1 Description

The QUINT-UPS uninterruptible power supply (UPS) is used to ensure that power for critical electrical loads continues to be supplied in the event of disturbances in the power supply network, e.g., due to mains breakdown or failure.

In doing so, the UPS switches to battery operation without interruption so that connected loads continue to be consistently supplied.

When mains power is restored, the UPS automatically returns to normal operation. The connected loads are again supplied via the power supply network and the battery is charged.

- Offline topology VFD-SS-311
- Comprehensive signaling
- Integrated USB interface
- High efficiency
- PC mode for safely shutting down industrial PCs, for example

Technical data (short form)

Nominal input voltage range	100 V AC ... 240 V AC
Input voltage range	90 V AC ... 264 V AC
Frequency range	45 Hz ... 65 Hz
Current consumption (100% load , Charger active)	6.9 A (100 V AC) / 2.86 A (240 V AC)
Nominal output voltage (U _N)	120 V AC / 230 V AC
Nominal output current (I _N) (100% load)	4.17 A (120 V AC) / 2.17 A (230 V AC)
Efficiency (100 % load, with charged energy storage)	> 97 %
MTBF (IEC 61709, SN 29500)	445469 h (40 °C)
Ambient temperature (operation)	-25 °C ... 60 °C (> 50 °C: 2,5 % / K)
Dimensions W/H/D	180 mm / 130 mm / 125 mm
Weight	2.5 kg
Battery technology	VRLA, VRLA-WTR, LI-ION
Nominal voltage (Energy storage)	24 V DC
Nominal capacity range	3.4 Ah ... 190 Ah (5x 38 Ah)



Make sure you always use the latest documentation.
It can be downloaded from the product at phoenixcontact.net/products.

2 Table of contents

1 Description 1

2 Table of contents 2

3 Ordering data 4

4 Technical data 6

5 Safety regulations and installation notes 13

 5.1 Symbols used 13

 5.2 Important safety and warning instructions 13

6 Design 15

 6.1 Function elements 15

 6.2 Device dimensions and keep-out areas 16

 6.3 Block diagram 17

7 Mounting and removing 18

 7.1 Convection 18

 7.2 Normal mounting position 18

 7.3 Mounting the UPS 18

 7.4 Removing the UPS 19

 7.5 Wall mounting 19

8 Device connection 21

 8.1 Network types 21

 8.2 Connection parameters 21

9 Device connection terminal blocks 22

 9.1 AC input 22

 9.2 AC output 22

 9.3 Battery DC 22

 9.4 Connection terminal block signaling 23

10 Interface 23

 10.1 USB mini type B 23

11 Installation of individual components 24

12 Device operation 25

 12.1 Setting the operating mode 25

 12.2 Remote 27

 12.3 Battery start (Bat.-Start 120 V / Bat.-Start 230 V) 28

13 Method of operation 29

 13.1 Operating modes 29

 13.2 Device start 29

 13.3 Switching behavior 29

 13.4 IQ technology 30

 13.5 Battery management 30

14	Signaling	31
14.1	LED indicators and signal outputs	32
14.2	Signal outputs	33
14.3	Signal inputs	33
14.4	LED bar graph display / Bat. LED	34
15	Derating.....	35
15.1	Ambient temperature	35
15.2	Installation height.....	35

3 Ordering data

Description	Type	Order No.	Pcs./Pkt.
QUINT UPS, IQ Technology, DIN rail mounting, USB (Modbus/RTU), input: 120 V AC / 230 V AC, output: 120 V AC / 230 V AC / 500 VA.	QUINT4-UPS/1AC/1AC/500VA/USB	1067327	1
Accessories	Type	Order No.	Pcs./Pkt.
Used for communication between an industrial PC and Phoenix Contact devices with USB-Mini-B connection.	MINI-SCREW-USB-DATACABLE	2908217	1
Fuse, nominal current: 10 A, length: 31.8 mm, diameter: 6.35 mm	FUSE 10A/400V GRL	2908358	1
2-piece universal wall adapter for securely mounting the device in the event of strong vibrations. The profiles that are screwed onto the side of the device are screwed directly onto the mounting surface. The universal wall adapter is attached on the left/right.	UWA 130	2901664	1
Universal wall adapter for securely mounting the device in the event of strong vibrations. The device is screwed directly onto the mounting surface. The universal wall adapter is attached on the top/bottom.	UWA 182/52	2938235	1
Energy storage device, lead AGM, VRLA technology, 24 V DC, 3.4 Ah, tool-free battery replacement, automatic detection, and communication with QUINT UPS-IQ	UPS-BAT/VRLA/24DC/3.4AH	2320306	1
Energy storage device, lead AGM, VRLA technology, 24 V DC, 7.2 Ah, tool-free battery replacement, automatic detection, and communication with QUINT UPS-IQ	UPS-BAT/VRLA/24DC/7.2AH	2320319	1
Energy storage device, lead AGM, VRLA technology, 24 V DC, 12 Ah, tool-free battery replacement, automatic detection, and communication with QUINT UPS-IQ	UPS-BAT/VRLA/24DC/12AH	2320322	1
Energy storage, lead AGM, VRLA technology, 24 V DC, 20 Ah, automatic detection and communication with QUINT UPS-IQ	UPS-BAT/VRLA/24DC/20AH	1109004	1
Energy storage device, lead AGM, VRLA technology, 24 V DC, 38 Ah, automatic detection, and communication with QUINT UPS-IQ	UPS-BAT/VRLA/24DC/38AH	2320335	1
Energy storage device, lead AGM, VRLA technology, 24 V DC, 13 Ah, tool-free battery replacement, automatic detection, and communication with QUINT UPS-IQ	UPS-BAT/VRLA-WTR/24DC/13AH	2320416	1
Energy storage device, lead AGM, VRLA technology, 24 V DC, 26 Ah, tool-free battery replacement, automatic detection, and communication with QUINT UPS-IQ	UPS-BAT/VRLA-WTR/24DC/26AH	2320429	1
Energy storage device, LI-ION technology, 24 V DC, 120 Wh, for ambient temperatures of -20°C ... 60°C, automatic detection and communication with QUINT UPS-IQ	UPS-BAT/LI-ION/24DC/120WH	2320351	1

Accessories	Type	Order No.	Pcs./Pkt.
Energy storage device, LI-ION technology, 24 V DC, 924 Wh, for ambient temperatures of -25 °C ... 60 °C, automatic detection and communication with QUINT UPS-IQ	UPS-BAT/LI-ION/24DC/924WH	2908232	1
Type 2/3 surge protection, consisting of protective plug and base element, with integrated status indicator and remote signaling for single-phase power supply networks. Nominal voltage 120 V AC/DC.	PLT-SEC-T3-120-FM-UT	2907918	5
Type 2/3 surge protection, consisting of protective plug and base element with screw connection. For single-phase power supply network with integrated status indicator and remote signaling. Nominal voltage 230 V AC/DC.	PLT-SEC-T3-230-FM-UT	2907919	5



Our range of accessories is being continually extended, our current range can be found in the download area.

4 Technical data

Input data	
Nominal input voltage range	100 V AC ... 240 V AC
Input voltage range	90 V AC ... 264 V AC
Frequency range	45 Hz ... 65 Hz
Current consumption (100% load , Charger active)	6.9 A (100 V AC) / 2.86 A (240 V AC)
Max. permissible backup fuse	25 A
Current consumption Battery operation	19 A (24 V DC)

Input connection data	
Connection method	Screw connection
Conductor cross section, rigid	0.2 mm ² ... 6 mm ²
Conductor cross section, flexible	0.2 mm ² ... 4 mm ²
Conductor cross section flexible, with ferrule with plastic sleeve	0.2 mm ² ... 4 mm ²
Conductor cross section flexible, with ferrule without plastic sleeve	0.2 mm ² ... 4 mm ²
Conductor cross section AWG/kcmil	30 ... 10
Stripping length	8 mm
Tightening torque	0.5 Nm ... 0.6 Nm

General output data	
Apparent power	500 VA
Real power	400 W
Power factor (cos phi)	0.8
Nominal output current (I _N) (100% load)	4.17 A (120 V AC) / 2.17 A (230 V AC)
Switch-over time	< 10 ms
Classification in accordance with IEC 62040-3	VFD-SS-311

Output data Normal operation	
Nominal output voltage (U _N)	120 V AC / 230 V AC
Nominal output frequency	60 Hz ±5 Hz / 50 Hz ±5 Hz
Fuse, internal	10 A / 400 V / gRL
Overload capability	in accordance with internal fuse
Efficiency (100 % load, with charged energy storage)	> 97 %

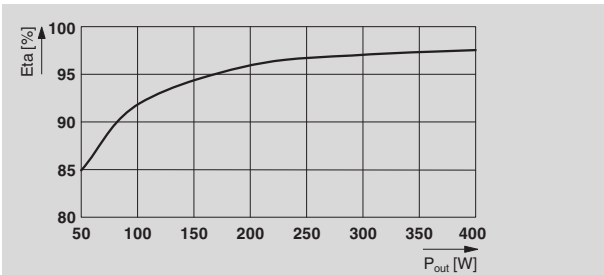

Normal operation power dissipation	120 V AC	230 V AC
No load	typ. 9 W	typ. 10 W
Nominal load	typ. 10 W	typ. 11 W

Output data Battery operation	
Nominal output voltage (U_N)	120 V AC $\pm 2\%$ / 230 V AC $\pm 2\%$
Nominal output frequency	60 Hz / 50 Hz
Output frequency tolerance	$\pm 5\%$ (grid-guided) , $\pm 0.5\%$ (self-guided)
Form of output voltage	Pure sine
Crest factor	2.8
Total harmonic distortion factor (THD)	< 3 % (linear load) , < 8 % (non-linear load)
Overload capability	105 % (Permanent) 120 % / 150 % (20 s / 5 s, then shutdown)
Electronic current limitation	> 2,5 x I_N (> 200 ms)
Efficiency (100% load)	~ 87 %

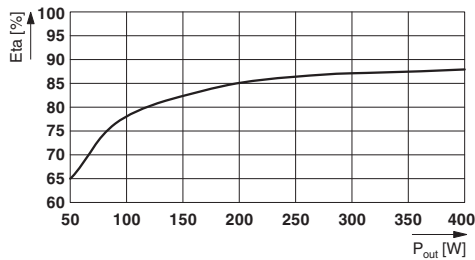

Battery operation power dissipation	120 V AC	230 V AC
No load	approx. 23 W	approx. 24 W
Nominal load	approx. 57 W	approx. 54 W

Output connection data	
Connection method	Screw connection
Conductor cross section, rigid	0.2 mm ² ... 6 mm ²
Conductor cross section, flexible	0.2 mm ² ... 4 mm ²
Conductor cross section flexible, with ferrule with plastic sleeve	0.2 mm ² ... 4 mm ²
Conductor cross section flexible, with ferrule without plastic sleeve	0.2 mm ² ... 4 mm ²
Conductor cross section AWG/kcmil	30 ... 10
Stripping length	8 mm
Tightening torque	0.5 Nm ... 0.6 Nm

Energy storage

Battery technology	VRLA, VRLA-WTR, LI-ION (see section: Ordering data)
Nominal voltage	24 V DC
End-of-charge voltage	24 V DC ... 31 V DC (temperature compensated)
Charge characteristic curve	IU ₀ U
Deep discharge protection	20 V DC ... 24 V DC (can be parameterized)
Nominal capacity range	3.4 Ah ... 190 Ah (5x 38 Ah)
Charging voltage	max. 31 V DC
Charge current	max. 5 A
Permissible backup fuse	50 A

Energy storage connection data

Connection method	Screw connection
Conductor cross section, rigid	0.2 mm ² ... 6 mm ²
Conductor cross section, flexible	0.2 mm ² ... 4 mm ²
Conductor cross section flexible, with ferrule with plastic sleeve	0.2 mm ² ... 4 mm ²
Conductor cross section flexible, with ferrule without plastic sleeve	0.2 mm ² ... 4 mm ²
Conductor cross section AWG/kcmil	30 ... 10
Stripping length	8 mm
Tightening torque	0.5 Nm ... 0.6 Nm

Status and diagnostic indicator / signal output Alarm

Connection labeling	3.1
Switching output	Transistor output, active
Output voltage	24 V
Continuous load current	≤ 20 mA
LED status indicator	red

Status and diagnostic indicator / signal output Battery mode

Connection labeling	3.2
Switching output	Transistor output, active
Output voltage	24 V
Continuous load current	≤ 20 mA
LED status indicator	yellow

Status and diagnostic indicator / signal output AC OK

Connection labeling	3.3
Switching output	Transistor output, active
Output voltage	24 V
Continuous load current	≤ 20 mA
LED status indicator	green

Status and diagnostic indicator / signal output Ready	
Connection labeling	3.4
Switching output	Transistor output, active
Output voltage	24 V
Continuous load current	≤ 20 mA
Status and diagnostic indicator / signal output P>P_n	
Connection labeling	3.5
Switching output	Transistor output, active
Output voltage	24 V
Continuous load current	≤ 20 mA
Battery-operated start (Bat.-Start)	
Connection labeling	3.6, 3.7
Low signal	Connection to SGnd with < 2.7 kΩ
High signal	Open (> 200 kΩ between bat. start and SGnd)
Remote control Remote	
Connection labeling	3.8
Low signal	Connection to SGnd with < 2.7 kΩ
High signal	Open (> 35 kΩ between remote and SGnd)
Digital control input (configurable)	
Low active digital control inputs	
Signal ground SGnd	
Connection labeling	3.9
Function	Signal ground
Reference potential	For signal inputs and signal outputs
Signal connection data	
Connection method	Screw connection
Conductor cross section, rigid	0.2 mm ² ... 1.5 mm ²
Conductor cross section, flexible	0.2 mm ² ... 1.5 mm ²
Conductor cross section flexible, with ferrule with plastic sleeve	0.2 mm ² ... 1.5 mm ²
Conductor cross section flexible, with ferrule without plastic sleeve	0.2 mm ² ... 1.5 mm ²
Conductor cross section AWG/kcmil	30 ... 12
Stripping length	8 mm
Tightening torque	0.5 Nm ... 0.6 Nm
Data interface	
Connection labeling	5.1
Interface designation	USB (Modbus/RTU)
USB classification	MINI-USB Type B
USB standard	USB 2.0
Locking	Screw
Electrical isolation	yes

Device combinations

Connection in parallel	no
Connection in series	no

General data

Overvoltage category	II
MTBF (IEC 61709, SN 29500)	445469 h (40 °C)
Degree of protection	IP20
Class of protection	I
Dimensions (W/H/D)	180 mm / 130 mm / 125 mm
Weight	2.5 kg

Ambient conditions

Ambient temperature (operation)	-25 °C ... 60 °C
Derating (Output power)	> 50 °C: 2,5 % / K
Ambient temperature (storage/transport)	-40 °C ... 85 °C
Humidity at 25 °C, non-condensing	≤ 95 %
Installation height	≤ 3000 m
Derating (Output power)	> 2,000 m: 0.6 % / 100 m
Degree of pollution	3 (≤ 130 V AC) / 2 (> 200 V AC)
Vibration (operation)	5 Hz ... 100 Hz, 0.7g (EN 60068-2-6)
Shock	20g in all directions (EN 60068-2-27)

Standards

Uninterruptible power supply systems	EN 62040-1
--------------------------------------	------------

Approvals

UL	UL/C-UL Recognized UL 1778
----	----------------------------



Current approvals/permissions for the product can be found in the download area under phoenixcontact.net/products

Electromagnetic compatibility / Conformance with EMC Directive 2014/30/EU

Noise emission in accordance with EN 62040-2

Conducted noise emission	EN 62040-02 (Class C2)
Noise emission	EN 62040-02 (Class C2)
Harmonic currents	EN 61000-3-2 (Class A)
Flicker	EN 61000-3-3

Immunity in accordance with EN 62040-2

CE basic standard	EN 62040-2 requirement	Tested
Electrostatic discharge EN 61000-4-2		
Housing contact discharge	± 6 kV	± 6 kV
Housing air discharge	± 8 kV	± 8 kV
Comments	Criterion B	Criterion A
Electromagnetic HF field EN 61000-4-3		
Frequency range	80 MHz ... 1 GHz	80 MHz ... 6 GHz
Test field strength	10 V/m	10 V/m
Comments	Criterion A	Criterion A
Fast transients (burst) EN 61000-4-4		
Input	± 2 kV	± 2 kV
DC input	± 1 kV	± 2 kV
Output	± 1 kV	± 2 kV
Signal	± 2 kV	± 2 kV
Signal USB	--	± 2 kV
Comments	Criterion B	Criterion A (B for USB)
Surge voltage load (surge) EN 61000-4-5		
Input/Output	± 1 kV (symmetrical) ± 2 kV (asymmetrical)	± 1 kV (symmetrical) ± 2 kV (asymmetrical)
Signal	1 kV (asymmetrical)	1 kV (asymmetrical)
Comments	Criterion B	Criterion A
Conducted interference EN 61000-4-6		
Frequency range	0.15 MHz ... 80 MHz	0.15 MHz ... 80 MHz
Signal	10 V	1 kV (asymmetrical)
Comments	Criterion A	Criterion A
Power frequency magnetic field EN 61000-4-8		
Frequency	50 Hz	50 Hz
Signal	30 A/m	30 A/m
Comments	Criterion A	Criterion A

Key

Criterion A Normal operating behavior within the specified limits.

Criterion B Temporary impairment to operational behavior that is corrected by the device itself.



All technical specifications are nominal and refer to a room temperature of 25 °C and 70% relative humidity at 2000 m above sea level.

5 Safety regulations and installation notes

5.1 Symbols used

Instructions and dangers are labeled with the corresponding symbols in this installation note.



This is the safety alert symbol. It is used to alert you to potential personal injury hazards. Obey all safety measures that follow this symbol to avoid possible personal injuries.

There are different categories of personal injury that are indicated by a signal word.



WARNING

This indicates a hazardous situation which, if not avoided, could result in death or serious injury.



CAUTION

This indicates a hazardous situation which, if not avoided, could result in minor or moderate injury.

The following symbols are used to indicate potential damage, malfunctions, or more detailed sources of information.



NOTE

This symbol together with the signal word NOTE and the accompanying text alert the reader to a situation which may cause damage or malfunction to the device, hardware/software, or surrounding property.



This symbol and the accompanying text provide the reader with additional information or refer to detailed sources of information.



This indicates that the device can be hot and should not be touched without taking care.



This symbol and the accompanying text provide additional information on the correct disposal of used batteries.



This symbol and the accompanying text provide additional information on recycling.

5.2 Important safety and warning instructions



WARNING: Danger to life by electric shock!

- Only skilled persons may install, start up, and operate the device.
- For indoor use only.
- Never carry out work when voltage is present.
- Establish connection correctly and ensure protection against electric shock.
- Connect the protective conductor device terminal block  with ground.
- Operation of the device is only permitted in mains network systems with grounded neutral conductor. This mainly complies with the TN-C-S mains network type. National regulations must be observed.
- The incoming neutral conductor must be earthed at the source and must never be disconnected.
- Ensure that the primary-side wiring and secondary-side wiring are the correct size and have sufficient fuse protection.
- Cover termination area after installation in order to avoid accidental contact with live parts (e. g., installation in control cabinet).
- This unit receives power from more than one source - disconnect the input power source and the energy storage to de-energize this unit before servicing.
- Keep flames, embers or sparks away from the module.
- When connecting the batteries, observe the polarity and do not short circuit the pole terminals.
- Provide a switch/circuit breaker close to the device at the AC input, AC output and at the battery terminals, which are labeled as the disconnecting device for this device.
- Do not disconnect the fuse and / or battery connection under hazardous location conditions.



WARNING EXPLOSION HAZARD - Do not disconnect equipment unless power has been removed or the area is known to be non-hazardous.



CAUTION: Hot surface

Depending on the ambient temperature and the load, the housing of the uninterruptible power supply can become very hot (T > 65 °C).



NOTE

- Observe the national safety and accident prevention regulations.
- Assembly and electrical installation must correspond to the state of the art.
- The uninterruptible power supply is a built-in device. The protection class IP20 of the device is meant to be applied in a clean and dry environment.
- The device must be installed in a control cabinet that can be locked and only opened by specialist staff.
- Use in a CONTROLLED ENVIRONMENT - the unit is intended for installation in a temperature-regulated, indoor area that is relatively free of conductive contaminants.
- Depending on the ambient temperature and load on the uninterruptible power supply, the housing can become hot.
- Observe the mechanical and thermal limits of the device.
- Ensure sufficient convection. The minimum distance (above/below) is shown in the relevant figure.
- Ensure that the location is sufficiently ventilated.
- Mount the device horizontally (standard mounting position).
- Use copper cables with an operating temperature of >75°C (ambient temperature<55°C) and > 90°C (ambient temperature< 75°C).
- For the connection parameters, such as the required stripping length for wiring with and without ferrule, refer to the technical data.
- To reduce the risk of fire, connect only to a circuit provided with the following maximum branch circuit overcurrent protection in accordance with the National Electrical Code, ANSI/NFPA 70.
- To reduce the risk of fire, replace only with same type and rating of fuse.
- The uninterruptible power supply is maintenance-free. Repairs may only be carried out by the manufacturer. The warranty no longer applies if the housing is opened.
- The uninterruptible power supply may only be used for its intended use.
- Improper use invalidates the device protection.



More follows

- The switching outputs are active outputs according to SELV. These may only be operated on permitted SELV circuits.
- This equipment is an open-type device meant to be installed in an enclosure suitable for the environment that is only accessible with the use of a tool.
- This QUINT UPS is compatible with a large number of Phoenix Contact energy storage systems. The use of VRLA energy storage systems from other manufacturers is possible in principle, but has not been tested.
- Save these instructions – This data sheet contains important safety notes that should be followed during installation and maintenance of the UPS and batteries. For details on the battery, see manufacturer’s installation manual for battery installation and maintenance.

6 Design

6.1 Function elements

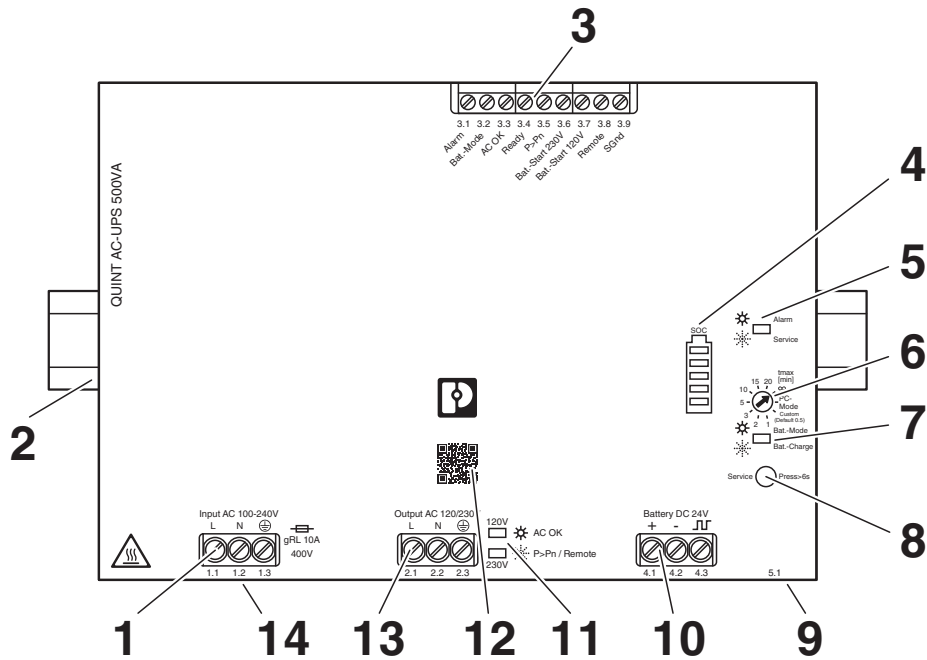

Figure 1 Position of the function elements

Key

No.	Designation
1	Input voltage connection terminal blocks: Input AC L/N/⊕
2	Universal DIN rail adapter (rear of housing)
3	Signaling connection terminal blocks
4	LED status indicator for battery charge state
5	LED status indicator Alarm / Service
6	Rotary selector switch for setting the buffer time t_{max} [min]
7	LED status indicator Bat. Mode / Bat. Charge
8	Service key for battery replacement
9	Communication interface (device underside)
10	Connection terminal blocks battery: +/- /signal
11	LED status indicator AC OK / $P > P_n$ / remote
12	QR code web link
13	Output voltage connection terminal blocks: Output AC L/N/⊕
14	Input fuse

6.2 Device dimensions and keep-out areas

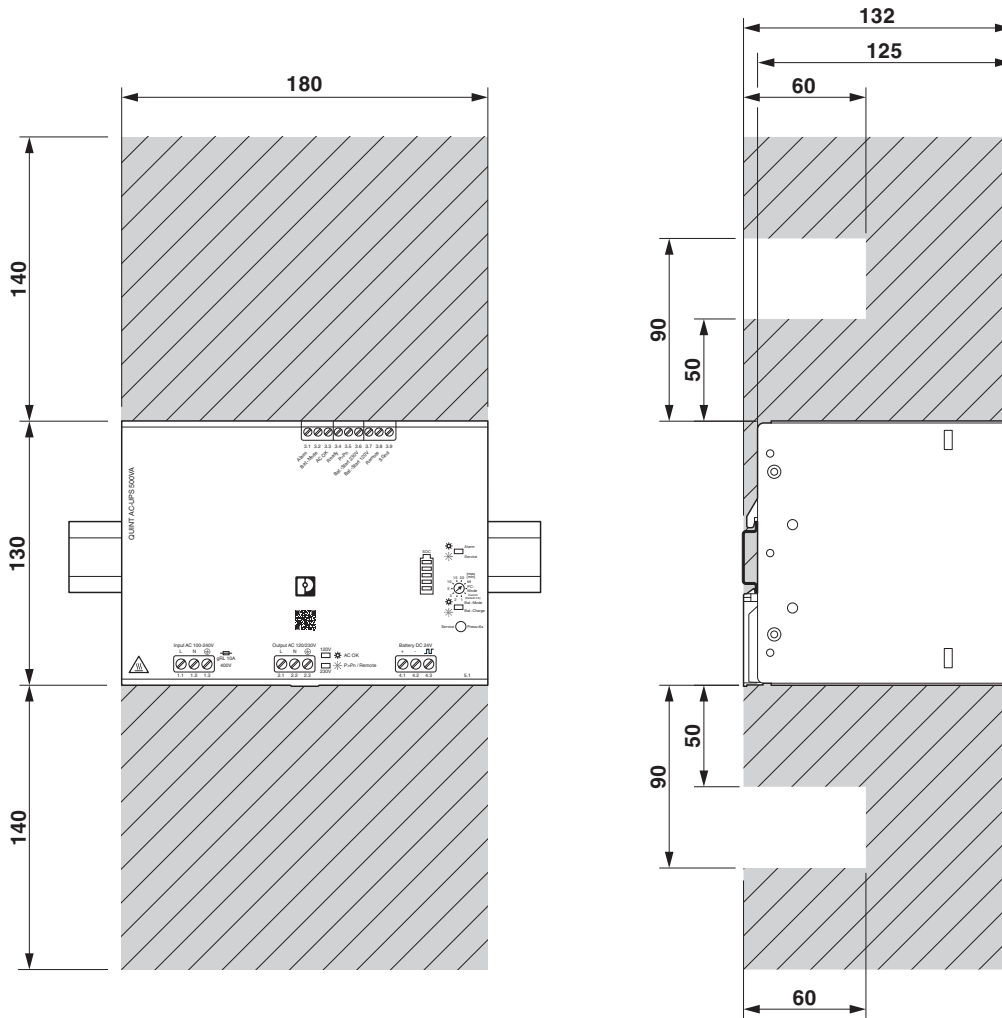

Figure 2 Device dimensions and keep-out areas

6.3 Block diagram

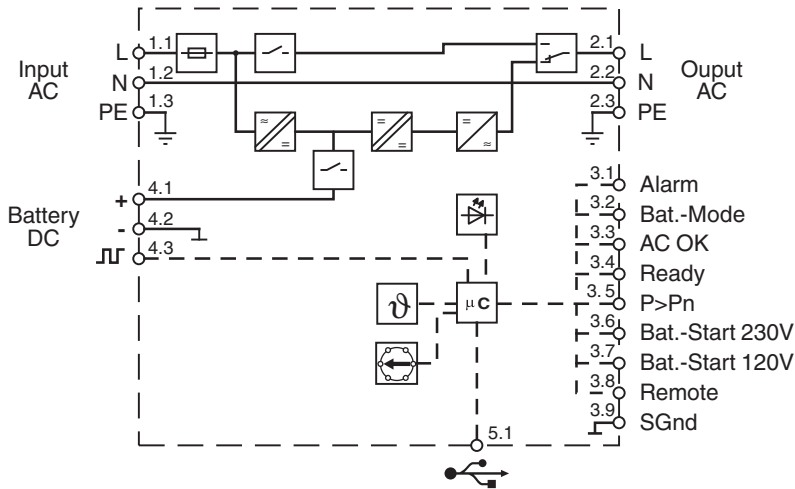











Figure 3 Block diagram

Key

Element	Designation
	Fuse
	Switch
	Changeover switch
	Rectifier with electrical isolation
	DC/DC converter with electrical isolation
	Inverter
	Microcontroller
	LED
	Temperature sensor
	Rotary selector switch

7 Mounting and removing



NOTE

The device must be installed in a control cabinet that can be locked and only opened by specialist staff.

7.1 Convection



CAUTION: Hot surface

Depending on the ambient temperature and the load, the housing of the uninterruptible power supply can become very hot ($T > 65\text{ °C}$).



NOTE: enable convection

To ensure sufficient convection, maintain an adequate minimum clearance between the UPS and above/below the installed devices. For information on the required minimum clearances, refer to the “Keep-out areas” section.

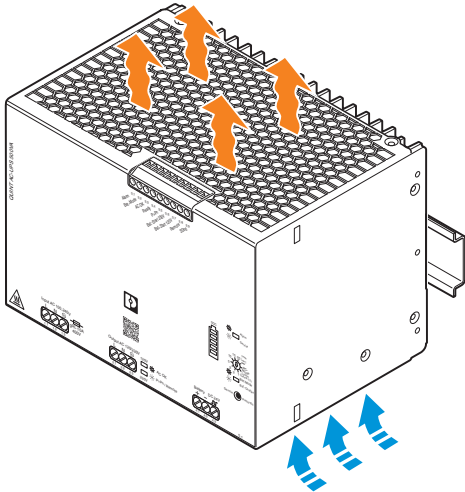

Figure 4 Convection

7.2 Normal mounting position



The device can be snapped onto all DIN rails according to EN 60715 and should only be mounted in the normal mounting position.

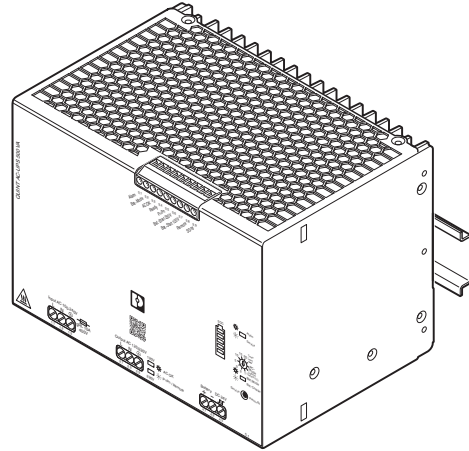

Figure 5 Normal mounting position

7.3 Mounting the UPS

Proceed as follows to mount the device:

1. In the normal mounting position the device is mounted on the DIN rail from above. Make sure that the universal DIN rail adapter is in the correct position behind the DIN rail (A).
2. Then press the device down until the universal DIN rail adapter audibly latches into place (B).
3. Check that the device is securely attached to the DIN rail.

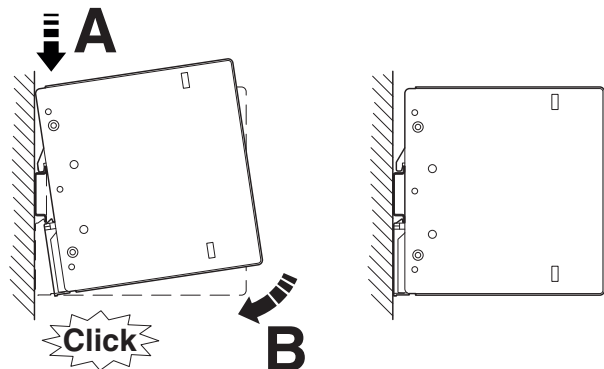

Figure 6 Snapping onto the DIN rail

7.4 Removing the UPS

Proceed as follows to remove the device:

1. Take a suitable screwdriver and insert this into the lock hole on the universal DIN rail adapter (A).
2. Release the lock by lifting the screwdriver (B).
3. Carefully swivel the device forward (C) so that the lock slides back into the starting position.
4. Then separate the device from the DIN rail (D).

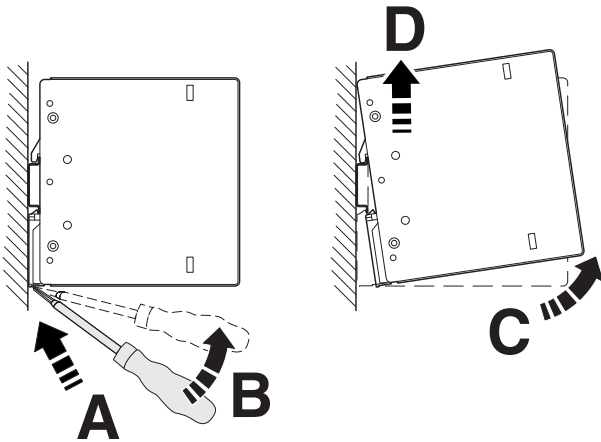

Figure 7 Removing from the DIN rail

7.5 Wall mounting

The UWA 182/52 universal wall adapter (Order No. 2938235) or UWA 130 universal wall adapter (Order No. 2901664) is used to attach the device directly to the mounting surface.

The use of the universal wall adapter is recommended under extreme ambient conditions, e.g., strong vibrations. Thanks to the tight screw connection between the uninterruptible power supply and the universal wall adapter or the actual mounting surface, an extremely high level of mechanical stability is ensured.



The maximum tightening torque of the Torx screw (Torx® T10) is 0.9 Nm.

Make sure you use suitable mounting material when attaching to the mounting surface.

7.5.1 Mounting the UWA 182/52 universal wall adapter



The UWA 182/52 universal wall adapter (Order No. 2938235) is attached to the device by means of the Torx screws of the universal DIN rail adapter.

Proceed as follows to disassemble the universal DIN rail adapter that comes pre-mounted:

1. Remove the screws for the universal DIN rail adapter using a suitable screwdriver (Torx 10).
2. Remove the universal DIN rail adapter from the rear of the uninterruptible power supply.
3. Position the universal wall adapter in such a way that the keyholes or oval tapers face up. The mounting surface for the device is the raised section of the universal wall adapter.
4. Insert the Torx screws into the appropriate hole pattern on the universal wall adapter so that the necessary mounting holes of the device can be accessed.
5. Screw the universal wall adapter onto the device.

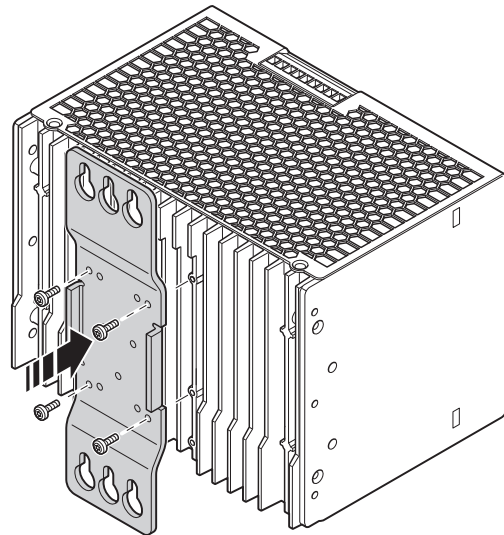

Figure 8 Mounting the UWA 182/52 universal wall adapter

7.5.2 Mounting the UWA 130 2-piece universal wall adapter



The UWA 130 universal wall adapter (Order No. 2901664) is attached to the device using the Torx screws provided.

Proceed as follows to disassemble the universal DIN rail adapter that comes pre-mounted:

1. Remove the screws for the universal DIN rail adapter using a suitable screwdriver (Torx 10).
2. Remove the universal DIN rail adapter from the rear of the uninterruptible power supply.
3. Position the two-piece universal wall adapter on the right and left side of the housing.
4. Insert the Torx screws into the appropriate hole pattern on the universal wall adapter so that the necessary mounting holes of the device can be accessed.
5. Screw the two-piece universal wall adapter onto the device.

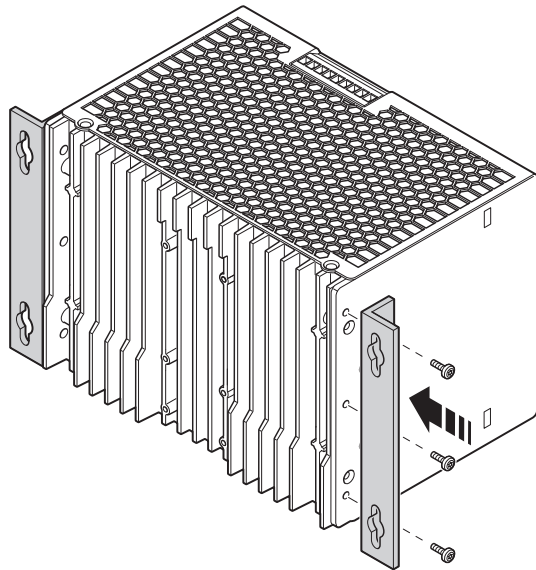

Figure 9 Mounting the UWA 130 universal wall adapter

8 Device connection

8.1 Network types



WARNING

Operation of the device is only permitted in supply system configurations with grounded neutral conductor.

This mainly complies with the TN-C-S supply system configuration. National regulations must be observed.



WARNING

The incoming neutral conductor must be earthed at the source and must never be disconnected.

8.2 Connection parameters





		 [mm ²]	 [mm ²]	 [mm ²]	 [mm ²]	AWG (Cu)	 [mm]	 [Nm]	[lb in]
Input AC 1.1...1.3	Screw	0.2-6	0.2-4	0.2-4	0.2-4	30-10	8	0.5-0.6	5-7
Output AC 2.1...2.3		0.2-6	0.2-4	0.2-4	0.2-4	30-10	8	0.5-0.6	5-7
Battery DC 4.1...4.3		0.2-6	0.2-4	0.2-4	0.2-4	30-10	8	0.5-0.6	5-7
Signals 3.1...3.9		0.2-1.5	0.2-1.5	0.2-1.5	0.2-1.5	30-12	8	0.5-0.6	5-7

Figure 10 Connection parameters

9 Device connection terminal blocks

9.1 AC input

The supply voltage is connected via the following connection terminal blocks: Input AC 100 - 240 V.

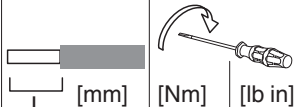
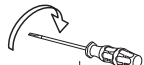
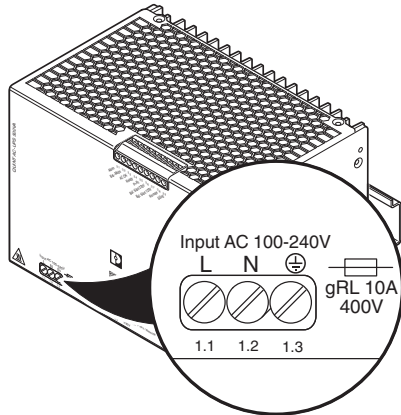

Figure 11 Input voltage connection terminal blocks: Input AC L/N/⊕ (1.1...1.3)

9.1.1 Protection of the primary side

It must be possible to switch the device off using a suitable disconnection device outside the power supply. The protection on the primary side, for example, is suitable for this (see section: Technical data).

The device's internal bypass fuse protects it, especially when it starts. This fuse is accessible from the outside and, if necessary, can be replaced.

Additional fuses inside the device protect it. Additional device protection is not required.



If an internal fuse trips, this is due to a device fault. In this case, the device must be inspected in the factory. Opening the device or repairing it yourself is prohibited.

9.2 AC output

Buffered output voltage is connected via connection terminal blocks: Output AC 120 / 230 V.

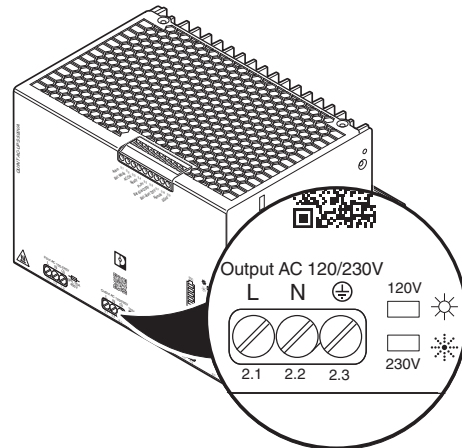

Figure 12 Output voltage connection terminal blocks: Output AC L/N/⊕ (2.1...2.3)

9.2.1 Protection of the secondary side

In normal operation, the UPS output is protected by the device's internal bypass fuse.

In battery operation, the UPS is resistant to electronic short circuit and idling.

Ensure that all output cables are dimensioned appropriately for the maximum output current or have separate protection.

9.3 Battery DC

The battery is connected via the following connection terminal blocks: Battery DC 24 V.

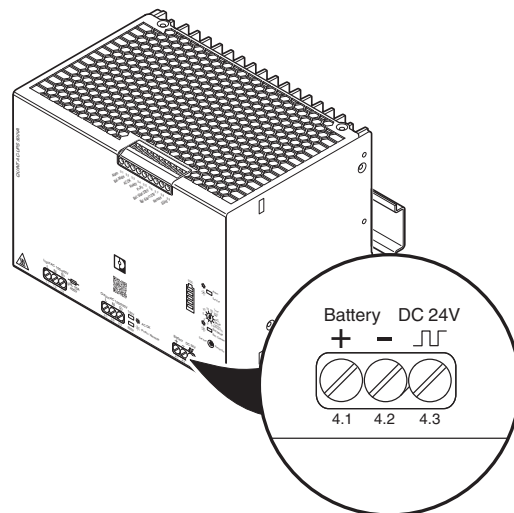

Figure 13 Battery connection terminal blocks: Battery DC +/-/Signal (4.1...4.3)

9.4 Connection terminal block signaling

The uninterruptible power supply has the signal outputs:

- Alarm (can be inverted via software)
- Bat. Mode (can be inverted and parameterized via software)
- AC OK (can be inverted and parameterized via software)
- Ready (can be inverted and parameterized via software)
- $P > P_n$ (can be inverted and parameterized via software)

The uninterruptible power supply also features the signal inputs:

- Remote
- Bat.-Start 120 V
- Bat.-Start 230 V

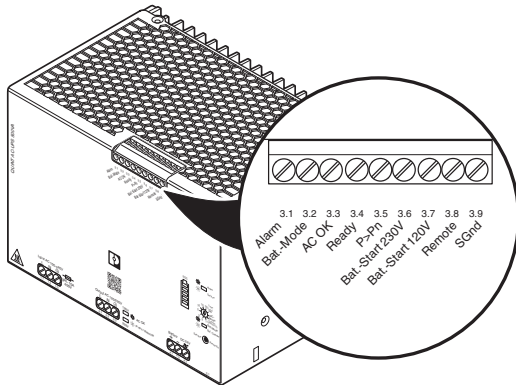

Figure 14 Connection terminal block signaling (3.1...3.9)

10 Interface

10.1 USB mini type B

The uninterruptible power supply is equipped with a USB Mini type B interface for data transmission.

A data cable is required for communicating with a PC or a higher-level controller.

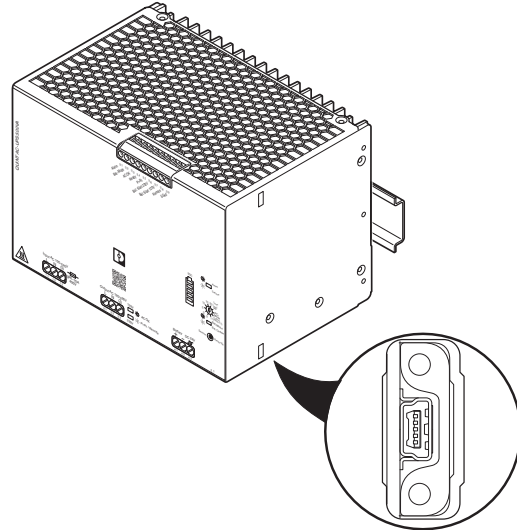

Figure 15 Service USB interface Mini type B (device bottom) (5.1)

10.1.1 MINI-SCREW-USB-DATACABLE

The uninterruptible power supply unit is connected to the USB PC connection with data cable MINI-SCREW-USB-DATACABLE (Order No. 2908217) via USB interface mini type B.

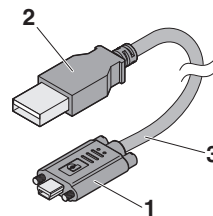

Figure 16 MINI-SCREW-USB-DATACABLE

No.	Designation
1	Mini type B USB connector with screw connection
2	USB plug type A
3	Cable length: 3 m

11 Installation of individual components



WARNING

Provide a switch/circuit breaker close to the device at the AC input, AC output and at the battery terminals, which are labeled as the disconnecting device for this device.

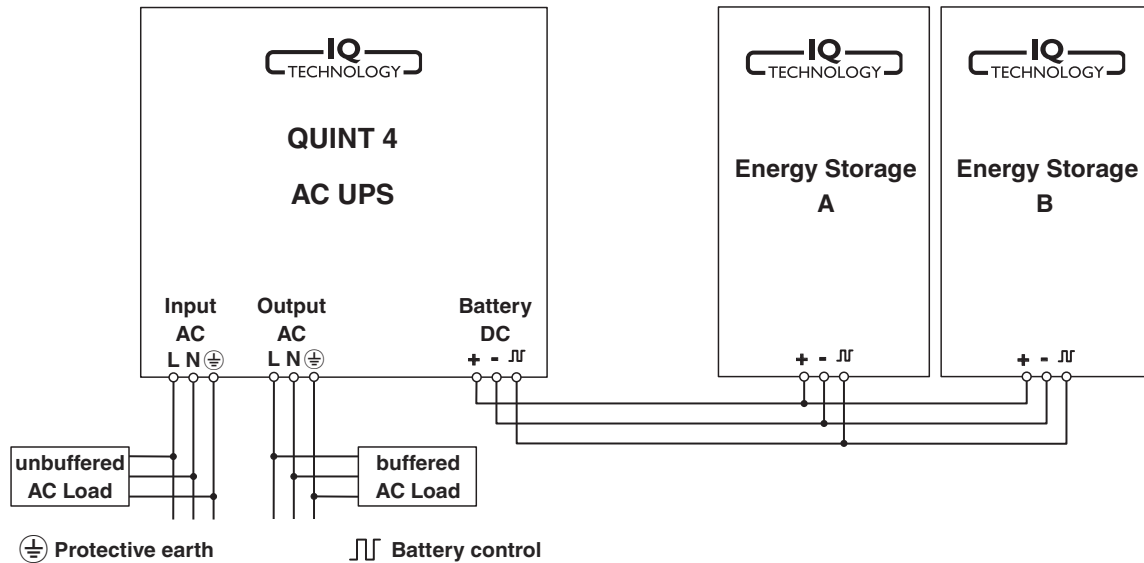

Figure 17 Schematic design



The image is a schematic representation of the design and does not contain all parts.

12 Device operation

Basic settings for commissioning can be made directly on the device using the rotary selection switch. Advanced settings can be made via the POWER MANAGEMENT SUITE software.



The latest software version is to be found in the product download area.

12.1 Setting the operating mode

You can set the following functions via the rotary selector switch on the front of the device:

- Buffer period
- PC mode

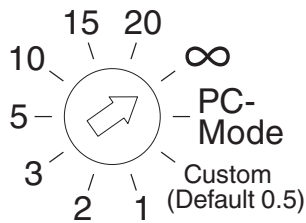

Figure 18 Rotary selector switch



Use a suitable screwdriver to set the rotary selector switch.

12.1.1 Buffer time

Rotary selector switch setting	Meaning
1, 2, 3, 5, 10, 15, 20	The UPS switches off after the set buffer time.
Custom (default 0.5)	The UPS switches off after the individual buffer time set via the POWER MANAGEMENT SUITE software. If a buffer time is not set, the UPS shuts down after 30 seconds.
∞ (unlimited, delivery state)	Buffering with the total stored energy. An alarm is generated as soon as the voltage of the energy storage falls below 20.4 V (default).

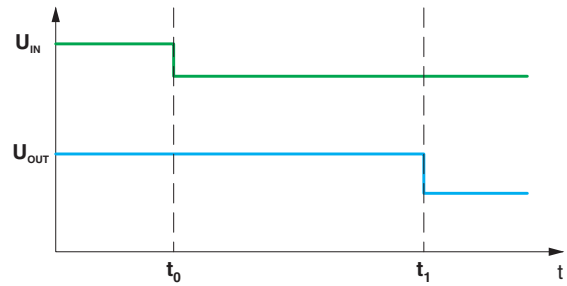

t_0 : mains power failure

t_1 : after the preset buffer time has expired, the output is switched off

12.1.2 PC mode

In PC mode, you can individually parameterize the chronological sequence of the UPS functions using the POWER MANAGEMENT SUITE software.

To access the PC mode of the UPS, set the rotary selector switch to PC mode.



The following components are required for the PC mode function:

Data cable MINI-SCREW-USB-DATACABLE (Order No. 2908217)

POWER MANAGEMENT SUITE software (Order No. tba)

In the event of a mains failure, one PC can continue to work, perform a controlled shutdown, and restart automatically.

1. Delay time

If the mains supply is not restored during the delay time, the PC is shut down.

2. Program start

After the delay time has expired, it is possible to start a program.

3. PC shutdown

The time required for PC shutdown is set here.

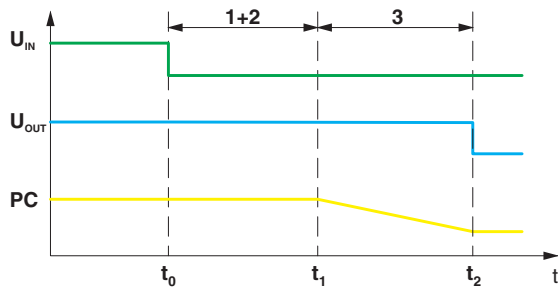

t_0 : mains power failure
 t_1 : delay time and program runtime have expired, PC will be shut down
 t_2 : the PC has shut down, the output will be switched off

4. PC no-load time

Only if the PC is shut down and the mains supply is restored in the meantime is the output voltage interrupted for the reset time and the PC then started automatically.

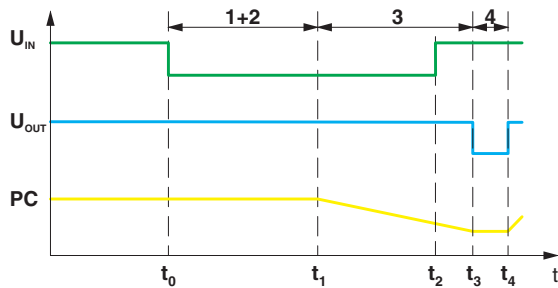

t_0 : mains power failure
 t_1 : delay time and program runtime have expired, PC will be shut down
 t_2 : mains restored while PC is shutting down
 t_3 : the PC has shut down and the output will be switched off, PC no-load time starts
 t_4 : the PC no-load time has expired, PC is starting back up

12.1.3 Service mode

When working in a system, it may be necessary to switch the uninterruptible power supply unit over to service mode.



Figure 19 Service mode buttons



In this operating mode, DC battery connection terminal blocks are deactivated using software. The active signal output is always activated when the unit is switched over to service mode.

Energy storage device replacement



WARNING

When connecting the batteries take note of the polarity.

Do not short circuit the pole terminals.

The batteries are maintenance free and may not be opened.



NOTE

When replacing batteries, always use new batteries from the same production batch.

When replacing batteries, you should always replace all of the batteries in use.



When storing the battery modules, observe the latest startup date and recharge the batteries if necessary. The batteries may only be recharged using the uninterruptible power supply.

To replace the energy storage device, proceed as follows:

1. Press and hold down the Service Mode button more than 6 s.
2. Remove the fuses.
3. Remove the cabling of the battery blocks.
4. Remove the batteries.
5. Install the new batteries.
6. Connect the cabling of the battery blocks.
7. Insert the fuses.
8. Exit Service mode.
 - a) With acknowledgment of the battery replacement: Press and hold down the Service Mode button for more than 6 s (the LED bar graph flashes 6 times and the red LED goes out). Acknowledge the battery replacement to confirm it. Assuming that there are new batteries, the SOH (State of Health) and SOC (State of Charge) are recalculated.
 - b) Without acknowledgment of the battery replacement: Press and hold down the Service Mode button for more than 1 s and less than 6 s (the red LED goes out).
9. Set the buffer time or PC mode.

Notes on disposal



Do not dispose of the UPS and battery modules in household waste! They should be disposed of according to the currently applicable national regulations.



You can return used batteries and accumulators to Phoenix Contact or the manufacturer.

12.2 Remote

You can use the Remote signal terminal to:

1. Deactivate and exit battery operation.
2. Perform controlled shutdown of the PC in normal operation and battery operation.
3. Perform controlled shutdown of the PC in battery operation.
4. Switch the UPS output off or on.

To perform these steps, you must connect the Remote signal terminal to the SGnd signal terminal.

1. Remote deactivates battery operation

You can deactivate battery operation using this function. This function is always active when a buffer time has been preset.

This function is the default setting in PC mode.

In normal operation, the remote signal is indicated by the flashing green LED (see section: Signaling).

In the event of mains failure, battery operation is not started.

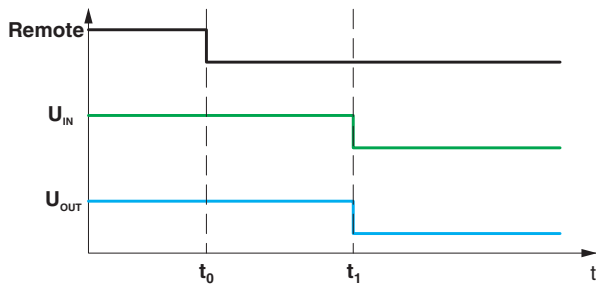

t_0 : Remote signal is set in normal operation

t_1 : no input voltage, output will be switched off

If the Remote signal is set in battery operation, battery operation is exited immediately. The UPS output is switched off. This procedure cannot be reversed. The UPS is only activated once the input voltage is applied.

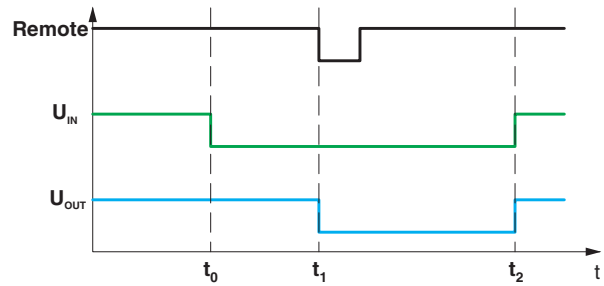

t_0 : no input voltage

t_1 : remote signal is set in battery operation, output will be switched off

t_2 : input voltage restored, output will be switched on

2. Remote starts undelayed PC-Shutdown

You can shut down the PC immediately via the POWER MANAGEMENT SUITE software.

This setting only applies in PC mode.

The remote signal is indicated by the flashing green LED (see section: Signaling).

The PC shuts down, and the delay time under Item 1 is skipped (see PC mode section).

Once the PC has shut down, the UPS output is switched off. When input voltage is present, the connected energy storage devices remain charged and the system is ready to use. When you reset the Remote signal, the UPS output is switched on again.

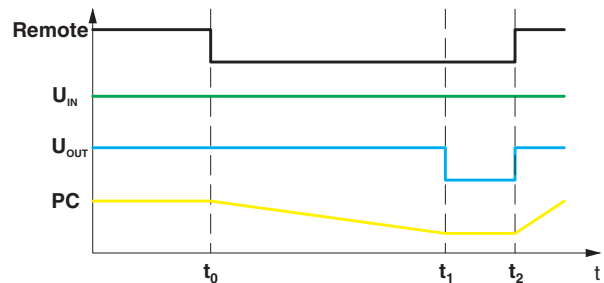

t_0 : Remote signal is set during normal operation; PC is shut down

t_1 : PC has shut down, output will be switched off

t_2 : remote signal will be reset, output will be switched back on



Once the PC has shut down in battery operation, the uninterruptible power supply output is switched off. This procedure cannot be reversed. The uninterruptible power supply is not activated until the input voltage is applied.

3. Remote starts immediate PC shutdown only in battery operation

You can shut down the PC immediately upon going into battery operation using the POWER MANAGEMENT SUITE software.

This setting only applies in PC mode.

The remote signal is indicated by the flashing green LED (see section: Signaling).

If the remote signal is set in normal operation, the PC is shut down when battery operation is entered. The delay time under Item 1 is skipped (see section: "PC mode").



Once the PC has shut down in battery operation, the uninterruptible power supply output is switched off. This procedure cannot be reversed. The uninterruptible power supply is not activated until the input voltage is applied.

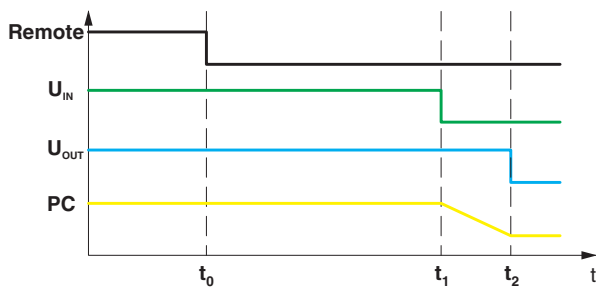

- t_0 : Remote signal is set in normal operation
- t_1 : no input voltage, PC shutdown begins immediately
- t_2 : the PC has shut down, the output will be switched off

4. Remote switches the output off/on

With this function, you can switch the UPS output off or on in normal operation.

This function is only possible when a buffer time has been set.

In PC operation, you cannot use this function.

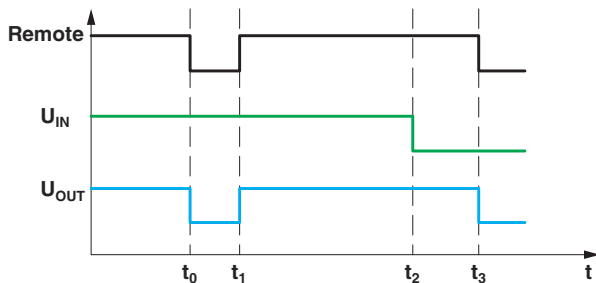

- t_0 : Remote signal is set in normal operation; output is switched off

t_1 : Remote signal is reset in normal operation, output is switched back on

t_2 : Mains failure

t_3 : The remote signal is set in battery operation, output is switched off

If the Remote signal is set in battery operation, battery operation is exited immediately. The UPS output is switched off. This procedure cannot be reversed. The UPS is only activated once the input voltage is applied.

12.3 Battery start (Bat.-Start 120 V / Bat.-Start 230 V)

You can use the signal terminal Bat.-Start 120 V or Bat.-Start 230 V to start the UPS without supply voltage on the input side and create an autonomous supply for the load. To do this, you must connect the signal terminal Bat.-Start 120 V or Bat.-Start 230 V to the SGnd signal terminal.

- Bat.-Start 120 V: The output voltage is 120 V / 60 Hz
- Bat.-Start 230 V: The output voltage is 230 V / 50 Hz

The maximum duration of the autonomous supply for the load depends on the charging state of the battery.

The signaling corresponds to the signaling for battery operation (see Signaling section).

To exit autonomous operation, you must disconnect the signal terminal Bat.-Start 120 V or Bat.-Start 230 V and the SGnd signal terminal.

If PC Mode operating mode is set, then in this case the PC shuts down immediately (see section Remote starts immediate PC shutdown).



Do not connect the communication line during a battery start, even for Phoenix Contact battery types.

An alarm is always generated when connecting a communication line to a non-initialized battery.

This does not negatively impact the supply to the connected load.

13 Method of operation

13.1 Operating modes

The uninterruptible power supply always functions in one of the two following operating modes:

Normal operation

The input voltage and frequency are in the valid range. The connected load is supplied with input voltage directly due to the offline topology of the UPS (see section: Block diagram).

Battery operation

The input voltage or the frequency is not in the valid range. The connected load is supplied from the battery via the internal UPS inverter (see section: Block diagram).

If the input voltage or frequency exits the valid range (as a rule, mains failure but also grid interruption or fluctuations), the UPS switches from normal to battery operation without interruption.



For this UPS, “without interruption” means that after 10 ms after a detected mains failure at the latest, 100% of the output voltage is present again.

If the input voltage or frequency returns to the valid range, the UPS switches from battery to normal operation without interruption.

13.2 Device start

When a valid input voltage is applied, the device starts. During the subsequent LED test, all LEDs on the front of the device are switched on for a short time. Next, the internal UPS inverter is synchronized with the input voltage and the UPS output is switched on.

The UPS always functions in one of two voltage ranges with one of two nominal frequencies:

- 100 V or 200 V range
- 50 Hz or 60 Hz

You can use the POWER MANAGEMENT SUITE software to set one of the following nominal voltages or nominal frequencies per voltage range:

- 100 V range:
100 V, 110 V, 120 V (= default), or 130 V
50 Hz or 60 Hz (= default)
- 200 V range:
200 V, 210 V, 220 V, 230 V (= default), or 240 V
50 Hz (= default) or 60 Hz

The UPS automatically detects whether the input voltage is in the 100-V or 200-V range and functions in accordance with the default values for the respective nominal voltage or nominal frequency.

13.3 Switching behavior

13.3.1 Switchover due to voltage changes

The percentages in the following table apply for switching from normal operation to battery operation. To switch from battery operation to normal operation and when switching on the UPS output when the device starts for the first time, you must subtract 5% hysteresis from the percentage values.

Valid input voltages

Voltage range [V]	Nominal voltage [V]	Lower limit [%]	Upper limit [%]	Lower switching threshold [V]	Upper switching threshold [V]
100 V	100	10	20	90	120
	110	15	20	94	132
	120	20	20	96	144
	130	20	20	104	156
200 V	200	20	20	160	240
	210	20	20	168	252
	220	20	20	176	264
	230	20	15	184	264
	240	20	10	192	264

Example:

Upon device start in 230 V nominal voltage operation, the UPS switches on the output in the range between 196 V...253 V or from battery operation to normal operation. Outside the 184 V...264 V range, the UPS switches from normal operation to battery operation.

13.3.2 Switchover due to changes in frequency

The frequency values in the following table apply for switching from normal operation to battery operation. To switch from battery operation to normal operation and when switching on the UPS output when the device starts for the first time, you must subtract a 2.5 Hz hysteresis from the values.

Valid input frequencies

Nominal frequency [Hz]	Lower switching threshold [Hz]	Upper switching threshold [Hz]
50 Hz	45 Hz	55 Hz
60 Hz	55 Hz	65 Hz

Example:

Upon device start in 60 V nominal frequency operation, the UPS switches on the output in the range between 57.5 V...62.5 V or from battery operation to normal operation.

Outside the 55 V...65 V range, the UPS switches from normal operation to battery operation.

In normal operation (= grid-managed), the internal UPS inverter follows the input frequency up to +/- 5% with reference to the nominal frequency. If the input frequency is outside these limits when switching from normal operation to battery operation, the output voltage frequency is either +/- 5% of the nominal frequency at the time battery operation begins. This depends on the direction in which the frequency varies.

As battery operation continues, the frequency of the output voltage will adjust to the nominal frequency within a few seconds (= automatic).

13.4 IQ technology

IQ Technology is an intelligent battery management system. In order to use IQ Technology, one of the following Phoenix Contact IQ battery types must be implemented:

- UPS-BAT/VRLA/24DC/...
- UPS-BAT/VRLA-WTR/24DC/...
- UPS-BAT/LI-ION/24DC/...

The respective battery type is connected to the uninterruptible power supply via three connecting cables. One cable each is connected to the plus (+) and minus (-) contacts for power transmission. A data cable is provided for communication.

The communication between the UPS and battery reveals the UPS of the battery type and the number of connected batteries. This uninterruptible power supply can use this information to calculate and configure the following parameters:

- SOC (State of Charge): current charging state and remaining runtime of the battery is always available.
- SOH (State of Health): displays the remaining battery life and warns of failures at an early stage.
- Optimal charging: the optimally set charging characteristics maximize the remaining service life of the battery and ensure the fastest possible recharge time and a high availability.

The batteries of the aforementioned type must first be fully charged (initialized) in order to determine the SOC and SOH. After this initial charging process, all IQ Technology functions are available.

13.5 Battery management

The uninterruptible power supply works with a 24 V battery system. You can connect a maximum of five batteries of the same type to the UPS.

The following table shows the charging times for different battery capacity levels:

Battery type	Battery capacity	Number of batteries	Charging time (approx.) [h]
UPS-BAT/VRLA/24DC/...	3.4AH	1	4
	7.2AH	1	4
	12AH	1	4
	20AH	1	6
	38AH	1	12
	38AH	2	23
UPS-BAT/VRLA-WTR/24DC/...	13AH	1	4
	26AH	1	8
	26AH	2	16
UPS-BAT/LI-ION/24DC/...	120WH	1	2
	120WH	2	4
	924WH	1	11
	924WH	2	22

Figure 20 Battery charging times for various battery capacities

The battery charger for the uninterruptible power supply operates according to the IUoU charge curve.

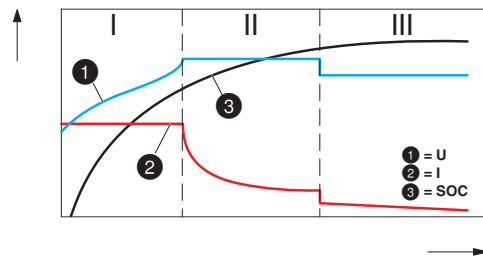

Figure 21 Charging characteristic

- Segment I: Base charge with a constant charging current until the end-of-charge equalization voltage is reached at the battery.
- Segment II: Charging with an end-of-charge equalization voltage until the charging current is reduced to a specific value.
- Segment III: Trickle charging with a constant trickle end-of-charge voltage to prevent self-discharge.

When using the Phoenix Contact IQ energy storage devices, all the necessary charging parameters are set automatically.

When using standard energy storage devices (not IQ Technology), you can set the following charging parameters using the POWER MANAGEMENT SUITE software:

Parameter	Area	Default
Nominal capacity	3,4 ... 190 Ah	-
Initial charging current	0.2" ... 5 A	1.2 A
Absorption charging end voltage	25 ... 30 V	28 V
Float charging end voltage	25 ... 30 V	27,6 V
Temperature compensation (of the charging voltages)	0 mV / K ... - 200 mV / K	-42 mV / K
End-of-discharge voltage	20 ... 24 V	20,4 V



When using Phoenix Contact IQ battery types, the configurable parameters are ignored. The values from the IQ battery types are used to configure the charger.

If segment III (see figure: Charging characteristic) is not achieved within a specific period, an alarm is generated (alarm: maximum charging time exceeded). The uninterruptible power supply uses the charging parameters to calculate the permitted time.

14 Signaling

Various LED indicators are available for visual function monitoring of the uninterruptible power supply. Active signal outputs can be used to forward this data to a higher-level control system.

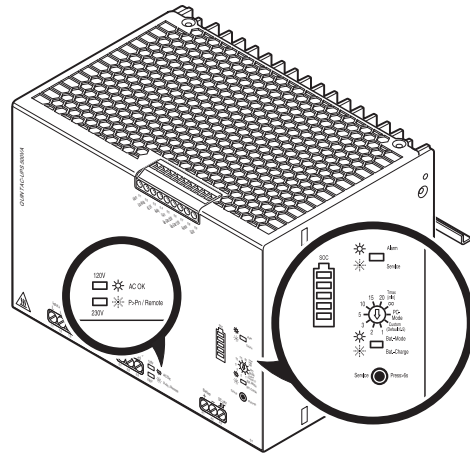

Figure 22 LED indicators

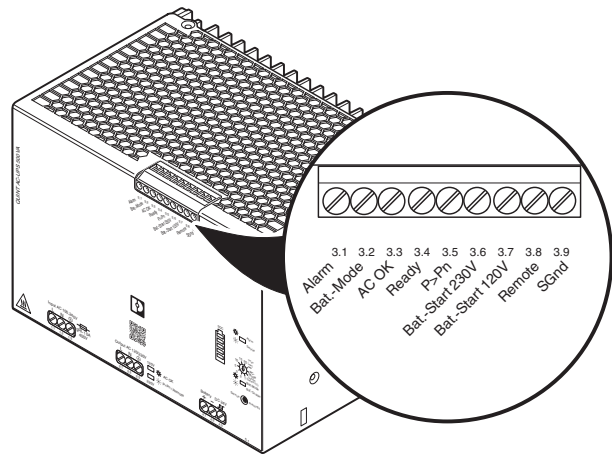

Figure 23 Signal inputs and outputs

For UPS signaling and the corresponding states, please refer to the table below.

14.1 LED indicators and signal outputs

Status LED			Switching output					Note
120V / 230V	Bat.	Alarm	Bat.-Mode	Ready	Alarm (active low)	AC OK	P>Pn	
○	○	○	low	low	low	low	low	Device off
●	●	●	low	low	high	low	low	Initialization, LED test (~3 sec.)
●	○	○	low	high	high	high	low	Mains operation, battery is fully charged
	☀ D = 50%	○	low	low or high	high	high	low	Mains operation, battery charging in process
	●	○	high	high or low	high	high	low	Battery mode
	○	●	low	low	low	high	low	Mains operation, battery failure
	○	☀ D = 50%	low	low	low	high	low	Mains operation, service mode for battery change
	●	●	high	low	low	high	low	Battery mode, battery voltage low
☀ D = 50%	○	○	low	high	high	high	high	Mains operation, overload, battery is fully charged
	●	○	high	high or low	high	high	high	Battery mode, overload
	☀ D = 50%	○	low	low or high	high	high	high	Mains operation, overload, battery charging in process
	○	●	low	low	low	high	high	Mains operation, overload, battery failure
	○	☀ D = 50%	low	low	low	high	high	Mains operation, overload, service mode for battery change
☀ D = 85%	○	○	low	high	high	high	low	Mains operation, remote contact shorted to SGnd, battery is fully charged
	☀ D = 50%	○	low	low or high	high	high	low	Mains operation, remote contact shorted to SGnd, battery charging in process
	●	○	high	high or low	high	high	low	Battery mode, remote contact shorted to SGnd, (only PC-Mode)
	○	●	low	low	low	high	low	Mains operation, remote contact shorted to SGnd, battery failure
	○	☀ D = 50%	low	low	low	high	low	Mains operation, remote contact shorted to SGnd, service mode for battery change



Figure 24 LED status indicators and signal outputs

14.2 Signal outputs

Alarm

When an alarm is present, the signal output is active (low level). The signal status can be inverted via the POWER MANAGEMENT SUITE software.

A digital transistor output is available as a signal contact.

This signal is indicated visually by a red LED.

Possible general alarms include:

- Shutdown when overloaded
- Service mode active
- Internal device error
- Impermissible device start

Possible battery alarms include:

- No battery connected
- Battery voltage low in normal operation
- Block voltage difference too large
- Permitted charging time exceeded
- End of the battery life reached: SOH (State of Health), can be adjusted using POWER MANAGEMENT SUITE
- Low battery voltage in battery operation, can be adjusted using POWER MANAGEMENT SUITE
- Low SOC (state of charge) in battery operation, can be adjusted using POWER MANAGEMENT SUITE
- Low remaining buffer time in battery operation, can be adjusted using POWER MANAGEMENT SUITE
- Different batteries hooked up in parallel
- Defective battery connected

Bat.-Mode

If there is a mains failure and the load is being supplied from the energy storage device, the signal output is active (high level). The signal status can be inverted via the POWER MANAGEMENT SUITE software.

A digital transistor output is available as a signal contact.

This signal is indicated visually by a yellow LED.

You can assign other additional information to this signal output using the POWER MANAGEMENT SUITE software.

AC OK

If the load is being supplied, the signal output is active (high level). The signal status can be inverted via the POWER MANAGEMENT SUITE software.

A digital transistor output is available as a signal contact.

This signal is indicated visually by a green LED.

Either the 120 V or 230 V LED lights up permanently (depending on the detected voltage range).

You can assign other additional information to this signal output using the POWER MANAGEMENT SUITE software.

Ready

If the energy storage device is fully charged (SOC = 100%), the signal output is active (high level).

The signal status can be inverted via the POWER MANAGEMENT SUITE software.

A digital transistor output is available as a signal contact.

You can assign other additional information to this signal output using the POWER MANAGEMENT SUITE software.

P>Pn

If the output power exceeds the maximum permitted output power, the signal output is active (high level).

The signal status can be inverted via the POWER MANAGEMENT SUITE software.

A digital transistor output is available as a signal contact.

This signal is indicated visually by a green LED.

Either the 120 V or 230 V LED flashes (depending on the detected voltage range).

You can assign other additional information to this signal output using the POWER MANAGEMENT SUITE software.

14.3 Signal inputs

Remote

You can activate and trigger various functions using the remote signal input. For further information, refer to the "Remote device operation" section.

This signal is indicated visually by a green LED.

Either the 120 V or 230 V LED flashes (depending on the detected voltage range).



A change made to the remote function using the POWER MANAGEMENT SUITE software is not applied until a corresponding status change of the remote signal input or device restart has been carried out.

Bat.-Start (Bat.-Start 120 V / Bat.-Start 230 V)

You can use the Bat.-Start 230 V or Bat.-Start 120 V signal terminals to start the UPS without supply voltage on the input side. For further information, refer to the "Device operation, battery start" section.

14.4 LED bar graph display / Bat. LED

The LED bar graph display consists of five individual segments and displays the SOC (state of charge) of the energy storage device. In this case, each segment corresponds to 20 % of the total capacity.

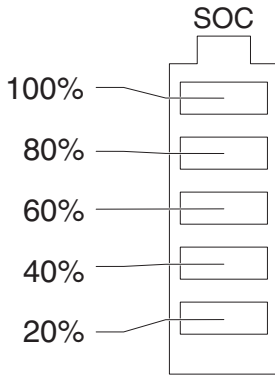

Figure 25 Bar graph display (SOC)

14.4.1 Charging



The charging time of the energy storage device depends on the capacity and energy supplied by the uninterruptible energy supply unit. The maximum charging time can last up to several hours.

IQ energy storage device - not initialized

As the state of charge (SOC) of the energy storage device is still unknown when installing it for the first time, the device must be fully charged once. Until the device has been fully charged for the first time, the LED bar graph display fills up repeatedly from bottom to top.

The bat. LED flashes during the charging process. If the energy storage device is fully charged, all five segments of the LED bar graph display light up and the bat. LED is off.

IQ energy storage device - initialized

The energy storage device has already been fully charged once. The energy storage characteristics are determined.

The individual segments of the LED bar graph display are illuminated based on the current state of charge (SOC) of the energy storage device. The current charging state is indicated by permanently illuminated segments. In this case, each segment corresponds to 20 % of the total capacity.

The flashing segment displays the charging process for the next 20 % segment.

Standard energy storage devices (without IQ technology)

The bottom LED bar graph display segment and bat. LED flash during the charging process. When the energy storage devices are fully charged, the bottom segment of the LED bar graph display continues to flash and the bat. LED is off.

14.4.2 Discharging

IQ energy storage device - not initialized

The energy content is not displayed because the state of charge of the energy storage device is unknown.

During the discharging process, the LED bar graph display empties from top to bottom. The bat. LED lights up permanently.

IQ energy storage device - initialized

The energy storage device has already been fully charged once. The energy storage characteristics are determined.

The individual segments of the LED bar graph display are illuminated based on the current state of charge (SOC) of the energy storage device. The current charging state is indicated by permanently illuminated segments. In this case, each segment corresponds to 20 % of the total capacity.

If the SOC (state of charge) < 10 %, the bottom segment of the LED bar graph display lights up in red.

During the discharging process, the bat. LED lights up permanently.

Standard energy storage devices (without IQ technology)

During the discharging process, the LED bar graph display is off. The bat. LED lights up permanently.

15 Derating

15.1 Ambient temperature

At an ambient temperature of up to 50 °C, the uninterruptible power supply supplies the continuous nominal power. At an ambient temperature of > 50 °C, a power derating of 2.5%/K should be observed for the uninterruptible power supply.

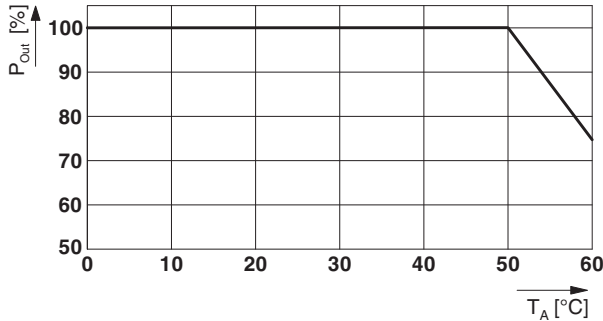

Figure 26 Temperature-dependent derating

15.2 Installation height

The uninterruptible power supply can be operated at an installation height of up to 2000 m without any limitations. Different data applies for installation locations above 2000 m due to the differing air pressure and the reduced convection cooling associated with this.

A power derating of 0.6%/100 m should be observed for installation heights between 2000 and 3000 m.

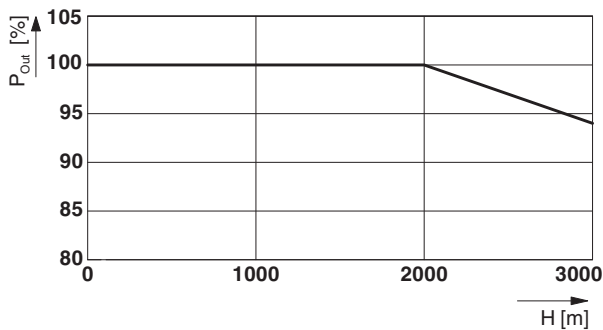

Figure 27 Altitude-dependent derating