

# APPROVAL SHEET

**WW25W, WW20W, WW10W, WW12W,  
WW08W, WW06W**

**±1%, ±5%**

Thick Film Normal Low Ohm Chip Resistors

RoHS Exemption free and Lead free

Size 2512, 2010, 1210, 1206, 0805, 0603

Anti-Sulfuration FOS 105°C 750hrs compliant

\*Contents in this sheet are subject to change without prior notice.

## FEATURE

1. High power rating and low TCR
2. High reliability and stability
3. Reduced size of final equipment
4. RoHS exemption free and Lead free products
5. Anti-Sulfuration FOS 105°C 750hrs compliant

## APPLICATION

- Power supply
- PDA
- Digital meter
- Computer
- Automotives
- Battery charger
- DC-DC power converter

## DESCRIPTION

The resistors are constructed in a high grade ceramic body (aluminum oxide). Internal metal electrodes are added at each end and connected by a resistive paste that is applied to the top surface of the substrate. The composition of the paste is adjusted to give the approximate resistance required and the value is trimmed to nominated value within tolerance which controlled by laser trimming of this resistive layer.

The resistive layer is covered with a protective coat. Finally, the two external end terminations are added. For ease of soldering the outer layer of these end terminations is Tin (lead free) alloy.

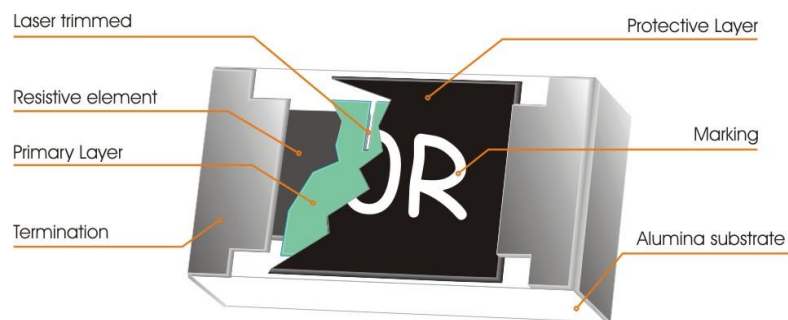
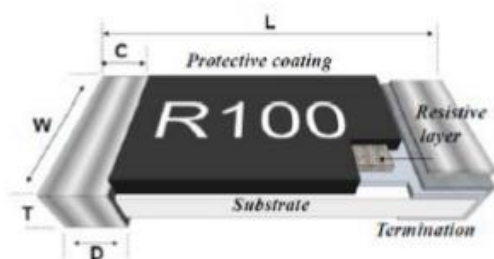

Fig 1. Construction of Chip-R

## CONSTRUCTION

※ R value  $\geq 40\text{mohm}$



※ R value  $\leq 39\text{m}\Omega$



**QUICK REFERENCE DATA**

Item	General Specification					
Series No.	WW25W	WW20W	WW10W	WW12W	WW08W	WW06W
Size code	2512 (6432)	2010 (5025)	1210 (3225)	1206 (3216)	0805 (2012)	0603 (1608)
Resistance Tolerance	±5%, ±1%					
Resistance Range	0.010Ω ~ 0.910Ω, E24					0.050Ω ~ 0.910Ω, E24
TCR (ppm/°C)	10 - 20mΩ: ±1000 22 - 39mΩ: ±600 40 - 47mΩ: ±200 50 - 91mΩ: ±100 100 - 910mΩ: ±100	10 - 20mΩ: ±1000 22 - 39mΩ: ±600 40 - 47mΩ: ±200 50 - 91mΩ: ±100 100 - 910mΩ: ±100	10 - 20mΩ: ±600 22 - 39mΩ: ±400 40 - 47mΩ: ±200 50 - 91mΩ: ±100 100 - 910mΩ: ±100	10 - 20mΩ: ±1000 22 - 39mΩ: ±600 40 - 47mΩ: ±200 50 - 91mΩ: ±100 100 - 910mΩ: ±100	10 - 20mΩ: ±1000 22 - 39mΩ: ±600 40 - 47mΩ: ±400 50 - 91mΩ: ±200 100 - 910mΩ: ±100	50 - 91mΩ: ±400 100 - 910mΩ: ±200
Max. dissipation at T <sub>amb</sub> =70°C	1 W	3/4W	2/3 W	1/3 W	1/4 W	1/8 W
Operation temperature	-55 ~ +155°C					

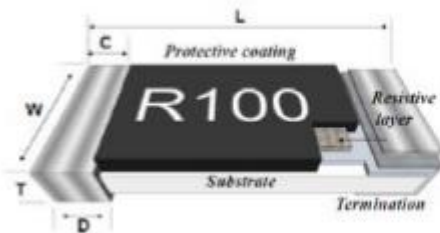

**R value ≥ 40mohm**

Symbol	WW25W	WW20W	WW10W	WW12W	WW08W	WW06W
L	6.30 ± 0.20	5.00 ± 0.20	3.10 ± 0.10	3.10 ± 0.10	2.00 ± 0.10	1.60 ± 0.10
W	3.10 ± 0.20	2.50 ± 0.20	2.60 ± 0.10	1.60 ± 0.10	1.25 ± 0.10	0.80 ± 0.10
T	0.60 ± 0.15	0.60 ± 0.10	0.55 ± 0.10	0.55 ± 0.10	0.50 ± 0.10	0.45 ± 0.10
C	0.60 ± 0.25	0.60 ± 0.25	0.50 ± 0.25	0.50 ± 0.25	0.40 ± 0.20	0.30 ± 0.20
D	0.90 ± 0.25	0.60 ± 0.25	0.50 ± 0.25	0.50 ± 0.25	0.40 ± 0.20	0.30 ± 0.20



**R value ≤ 39mΩ**

Symbol	WW25W	WW20W	WW10W	WW12W	WW08W
L	6.30 ± 0.20	5.00 ± 0.20	3.10 ± 0.15	3.10 ± 0.15	2.00 ± 0.10
W	3.10 ± 0.20	2.50 ± 0.20	2.60 ± 0.10	1.60 ± 0.10	1.25 ± 0.10
T	0.60 ± 0.15	0.60 ± 0.10	0.60 ± 0.10	0.55 ± 0.10	0.60 ± 0.10
C	0.25 ± 0.25	0.25 ± 0.25	0.25 ± 0.25	0.25 ± 0.20	0.25 ± 0.20
D	1.80 ± 0.30	1.10 ± 0.25	0.90 ± 0.25	0.90 ± 0.25	0.65 ± 0.20

## RECOMMENDED SOLDERING PAD

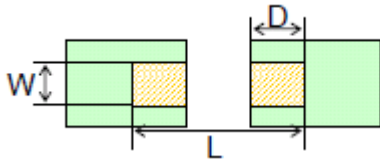

Symbol	WW25W	WW20W	WW10W	WW12W	WW08W	WW06W
WL	3.70mm	3.00mm	3.00mm	1.80mm	1.30mm	0.90mm
D	1.60mm	1.50mm	1.30mm	1.30mm	1.15mm	1.00mm
L	7.60mm	6.80mm	4.70mm	4.70mm	3.50mm	3.00mm

## MARKING

- **4-digits marking for 2512, 2010, 1210, 1206, 0805 size**

Each resistor is marked with a four-digit code on the protective coating to designate the nominal resistance value.

- **3-digits marking for 0603 size**
- Each resistor is marked with a three -digit code on the protective coating to designate the nominal resistance value.

### Resistance Marking (E-24 Series)

**R150**

4 digit marking for  $\pm 1\%$ ,  $\pm 5\%$  0805 , 1206 , 1210, 2010 , 2512

Examples. R150 = 150 m $\Omega$ , R020 = 20 m $\Omega$

**R50**

3 digit marking for  $\pm 1\%$ ,  $\pm 5\%$  0603

Examples. R12 = 120 m $\Omega$ , R50 = 500 m $\Omega$

**47M**

3 digit marking for  $\pm 1\%$ ,  $\pm 5\%$  0603 (47m $\Omega$ ~91m $\Omega$ )

Examples. 20M = 20 m $\Omega$

## FUNCTIONAL DESCRIPTION

### Product characterization

Standard values of nominal resistance are taken from the E24 series for resistors with a tolerance of  $\pm 5\%$  &  $\pm 1\%$ . The values of the E24 series are in accordance with "IEC publication 60063".

### Derating curve

The power that the resistor can dissipate depends on the operating temperature; see Fig.2

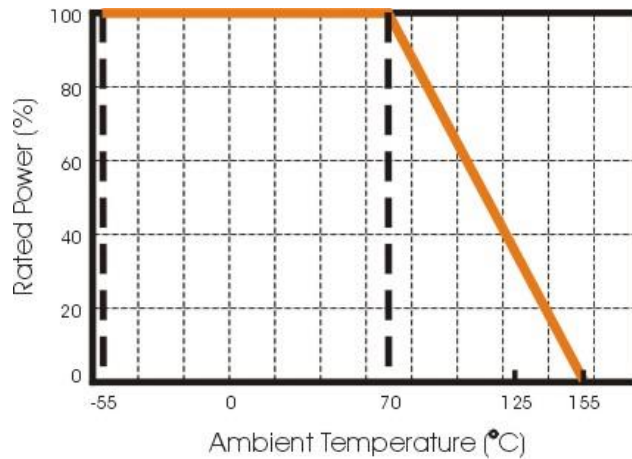

Figure 2 Maximum dissipation in percentage of rated power as a function of the ambient temperature

## SOLDERING CONDITION follows J-STD-020D

The robust construction of chip resistors allows them to be completely immersed in a solder bath of 260°C for 10 seconds. Therefore, it is possible to mount Surface Mount Resistors on one side of a PCB and other discrete components on the reverse (mixed PCBs). Surface Mount Resistors are tested for solderability at 235°C during 2 seconds. The test condition for no leaching is 260°C for 30 seconds. Typical examples of soldering processes that provide reliable joints without any damage are given in Fig 3.

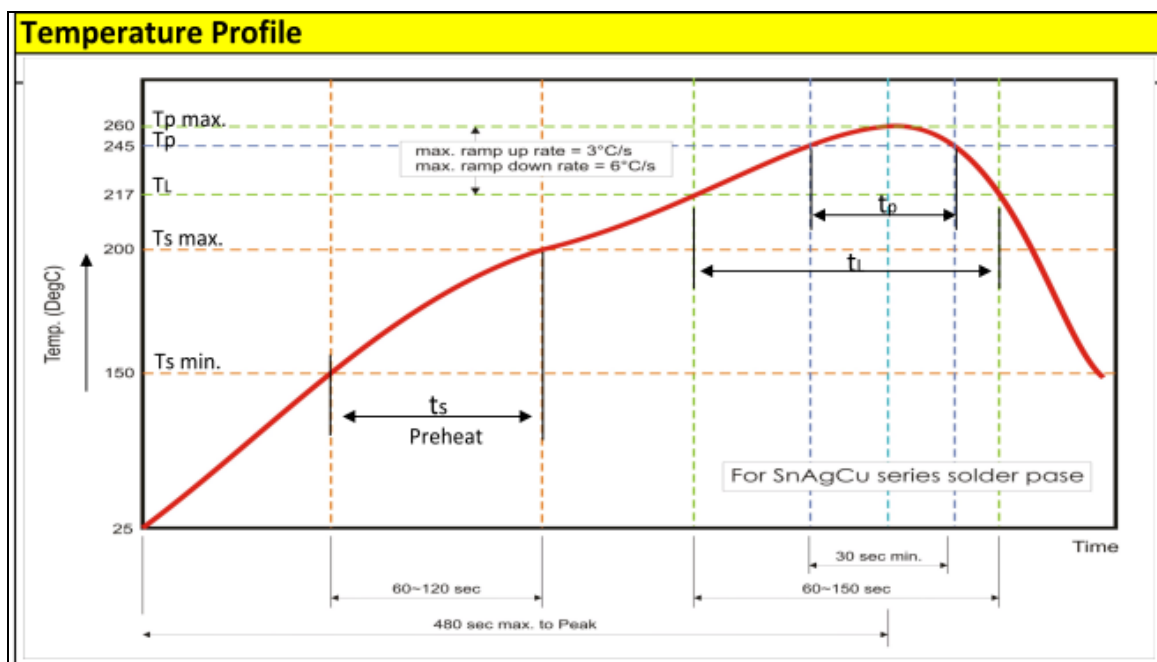

Fig 3. Infrared soldering profile

## CATALOGUE NUMBERS

The resistors have a catalogue number starting with:

WW12	W	R020	F	T	L
<b>Size code</b>	<b>Type code</b>	<b>Resistance code</b>	<b>Tolerance</b>	<b>Packaging code</b>	<b>Termination code</b>
WW25 : 2512	W : Thick film Power low ohm low TCR	0.020Ω = R020	J : ±5%	T : 7" Reel taping	L = Sn base (lead free)
WW20 : 2010		0.510Ω = R510	F : ±1%	Q : 10" Reel taping	
WW10 : 1210		0.025Ω = R025		G : 13" Reel taping	
WW12 : 1206					
WW08 : 0805					
WW06 : 0603					

Tape packaging WW10, WW12, WW08, WW06 : 8mm width paper taping

- 5,000pcs per 7" reel;
- 10,000pcs per 10" reel;
- 20,000pcs per 13" reel.

WW25, WW20: 12mm width emboss taping

- 4,000pcs per 7" reel;
- 8,000pcs per 10" reel;
- 16,000pcs per 13" reel.

**TEST AND REQUIREMENTS(JIS C 5201-1 : 1998)**

TEST	PROCEDURE	REQUIREMENT
Temperature Coefficient of Resistance(T.C.R) <b>Clause 4.8</b>	Natural resistance change per change in degree centigrade. $\frac{R_2 - R_1}{R_1(t_2 - t_1)} \times 10^6 \text{ (ppm/}^\circ\text{C)}$ $t_1 : 25^\circ\text{C}$ $R_1$ : Resistance at reference temperature $25^\circ\text{C}$ $R_2$ : Resistance at test temperature $155^\circ\text{C}$	Refer to "QUICK REFERENCE DATA"
Short time overload (S.T.O.L) <b>Clause 4.13</b>	Permanent resistance change after a 5second application of a 5 times rated power.	J: $\Delta R/R$ max. $\pm(2\%+0.5\text{m}\Omega)$ F: $\Delta R/R$ max. $\pm(1\%+0.5\text{m}\Omega)$
Solderability <b>Clause 4.17</b>	Un-mounted chips completely immersed for $3\pm 0.5$ second in a SAC solder bath at $245^\circ\text{C} \pm 2^\circ\text{C}$	good tinning (>95% covered) no visible damage
Resistance to soldering heat(R.S.H) <b>Clause 4.18</b>	Un-mounted chips completely immersed for $10\pm 1$ second in a SAC solder bath at $260^\circ\text{C} \pm 5^\circ\text{C}$	no visible damage J: $\Delta R/R$ max. $\pm(1\%+0.5\text{m}\Omega)$ F: $\Delta R/R$ max. $\pm(0.5\%+0.5\text{m}\Omega)$
Temperature cycling <b>Clause 4.19</b>	30 minutes at $-55^\circ\text{C} \pm 3^\circ\text{C}$ , 2~3 minutes at $20^\circ\text{C} + 5^\circ\text{C} - 1^\circ\text{C}$ , 30 minutes at $+155^\circ\text{C} \pm 3^\circ\text{C}$ , 2~3 minutes at $20^\circ\text{C} + 5^\circ\text{C} - 1^\circ\text{C}$ , total 5 continuous cycles	no visible damage J: $\Delta R/R$ max. $\pm(1\%+0.5\text{m}\Omega)$ F: $\Delta R/R$ max. $\pm(0.5\%+0.5\text{m}\Omega)$
Load life (endurance) <b>Clause 4.25</b>	1000 +48/-0 hours, loaded with RCWV or Vmax in chamber controller $70\pm 2^\circ\text{C}$ , 1.5 hours on and 0.5 hours off	J: $\Delta R/R$ max. $\pm(3\%+0.5\text{m}\Omega)$ F: $\Delta R/R$ max. $\pm(1\%+0.5\text{m}\Omega)$
Load life in Humidity <b>Clause 4.24</b>	1000 +48/-0 hours, loaded with RCWV or Vmax in humidity chamber controller at $40^\circ\text{C} \pm 2^\circ\text{C}$ and 90~95% relative humidity, 1.5hours on and 0.5 hours off	J: $\Delta R/R$ max. $\pm(3\%+0.5\text{m}\Omega)$ F: $\Delta R/R$ max. $\pm(1\%+0.5\text{m}\Omega)$
Bending strength <b>Clause 4.33</b>	Resistors mounted on a 90mm glass epoxy resin PCB(FR4); bending : 3mm for 0603/0805, 2mm for 1206 and above sizes, once for 10 seconds	no visible damage J: $\Delta R/R$ max. $\pm(1\%+0.5\text{m}\Omega)$ F: $\Delta R/R$ max. $\pm(0.5\%+0.5\text{m}\Omega)$
Adhesion <b>Clause 4.32</b>	Pressurizing force: 5N, Test time: $10\pm 1$ sec.	No remarkable damage or removal of the terminations
Insulation Resistance <b>Clause 4.6</b>	Test voltage: $100\pm 15\text{V}$	$I.R \geq 1\text{G}\Omega$
Sulfuration test ASTM B-809-95	ASTM B-809-95 $105^\circ\text{C}$ 750hrs	$\Delta R/R$ max. $\pm(2\%+0.5\text{m}\Omega)$

**PACKAGING**

Paper Tape specifications (unit :mm)

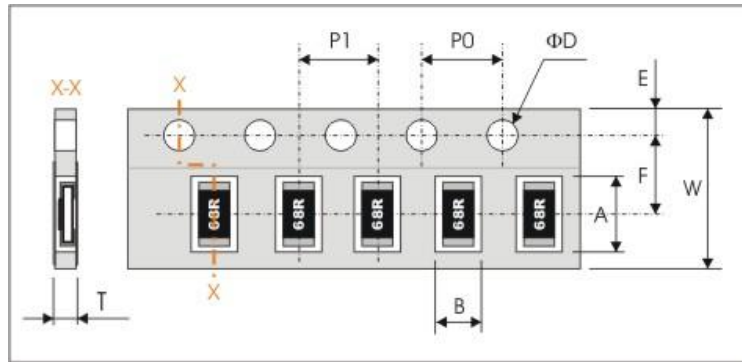

Series No.	A	B	W	F	E
WW25W	6.70±0.20	3.50±0.20	12.00±0.30	3.50±0.20	1.75±0.10
WW20W	5.50±0.20	2.80±0.20	12.00±0.30		
WW10W	3.60±0.20	3.00±0.20	8.00±0.30		
WW12W	3.60±0.20	2.00±0.20			
WW08W	2.40±0.20	1.65±0.20			
WW06W	1.90±0.20	1.10±0.20			

Series No.	P1	P0	ΦD	T
WW25W	4.00±0.10	4.00±0.10	Φ1.50 <sup>+0.1</sup> <sub>-0.0</sub>	Max. 1.2
WW20W				Max. 1.2
WW10W				Max. 1.0
WW12W				Max. 1.0
WW08W				Max. 1.0
WW06W				Max. 0.8

**Reel dimensions**

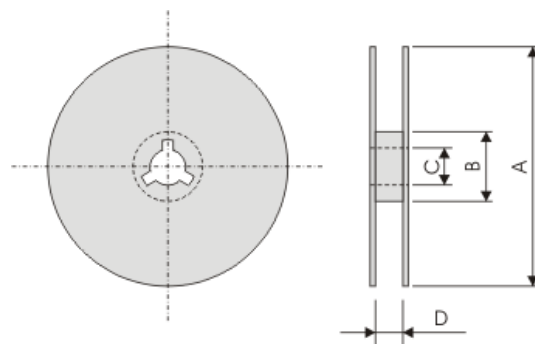

Symbol	A	B	C	D
7" reel	Φ178.0±2.0	Φ60.0±1.0	13.0±0.5	10.0±1.5 ( 8mm tape )
10" reel	Φ254.0±2.0	Φ100.0±1.0		13.8±1.5 (12mm tape)
13: reel	Φ330.0±2.0	Φ100.0±1.0		