PXle-2525 Specifications

2022-06-30



Contents

PXIe-2525 Specifications..... 3

PXIe-2525 Specifications

This document lists specifications for the PXIe-2525 . All specifications are subject to change without notice.

Topology	2-wire 16 Bank 4 × 1, 2-wire Octal 8 × 1, 2-wire Quad 16 × 1, 2-wire Dual 32 × 1, 2-wire 64 × 1
----------	---

Definitions

Warranted specifications describe the performance of a model under stated operating conditions and are covered by the model warranty.

Characteristics describe values that are relevant to the use of the model under stated operating conditions but are not covered by the model warranty.

- **Typical** specifications describe the performance met by a majority of models.
- **Nominal** specifications describe an attribute that is based on design, conformance testing, or supplemental testing.

Specifications are **Typical** unless otherwise noted.

Conditions

Specifications are valid at 23 °C unless otherwise noted.

All voltages are specified in DC, AC_{pk}, or a combination unless otherwise specified.

Input Characteristics

Maximum switching voltage

Channel-to-channel	150 V
Channel-to-ground	150 V, CAT O



Note This module is rated for Measurement Category I. It is intended to carry signal voltages no greater than 150 V. This module can withstand up to 800 V impulse voltage. Do not use this module for connection to signals or for measurements within Categories II, III, or IV. Do not connect to MAINS supply circuits (for example, wall outlets) of 115 VAC or 230 VAC. Refer to the **Read Me First: Safety and Electromagnetic Compatibility** document for more information about measurement categories.

Measurement Categories CAT I and CAT O (Other) are equivalent and are for measurements performed on circuits not directly connected to the electrical distribution system referred to as MAINS voltage. This category is for measurement of voltages from specially protected secondary circuits. Such voltage measurements include signal levels, special hardware, limited-energy parts of hardware, circuits powered by regulated low-voltage sources, and electronics.



Caution When hazardous voltages (>42.4 Vpk/60 V DC) are present on any channel, safety low-voltage (≤ 42.4 Vpk/60 V DC) cannot be connected to any other channel.

Maximum switching power	60 W, 62.5 VA
-------------------------	---------------



Caution The switching power is limited by the maximum switching current, the maximum voltage, and must not exceed 60 W, 62.5 VA.

CH-COM DC isolation resistance	>1 G Ω , typical at 25 °C
--------------------------------	------------------------------------

Maximum current

Switching	2 A (per channel)
Carry	2 A (per channel)
Minimum switch load	20 mV/1 mA



Note The PXIe-2525 is not recommended for 2-wire resistance measurements.



Note Switching inductive loads (for example, motors and solenoids) can produce high voltage transients in excess of the module's rated voltage. Without additional protection, these transients can interfere with module operation and impact relay life. For more information about transient suppression, visit ni.com/info and enter the Info Code relayflyback.

DC path resistance

Initial	<0.8 Ω , warranted
End-of-life	$\geq 1.8 \Omega$

DC path resistance is a combination of relay contact resistance and trace resistance. Measure path resistance by combining the resistance of the high and low signal paths from one row to one column. Contact resistance typically remains low for the life of a relay. At the end of relay life, the contact resistance rises rapidly above $\geq 1.8 \Omega$.

Thermal EMF	<10 μV
-------------	-------------------

RF Performance Characteristics

Bandwidth (-3 dB, typical at 23 °C) 50 Ω termination	≤ 10 MHz
Open channel isolation (typical at 23 °C) 50 Ω termination	
10 kHz	≥ 76 dB
100 kHz	≥ 63 dB
1 MHz	≥ 36 dB
Channel-to-channel crosstalk (typical at 23 °C) 50 Ω termination	
10 kHz	≤ -73 dB
100 kHz	≤ -52 dB
1 MHz	≤ -32 dB

Dynamic Characteristics

Relay operate time	
Typical	1 ms
Maximum	3.1 ms
Simultaneous drive limit	79 relays
Expected relay life	
Mechanical	1×10^8 cycles

Electrical

≤30 mV, ≤10 mA resistive	2.5×10^6 cycles
30 V, 1 A	5×10^5 cycles
30 V, 2 A	1×10^5 cycles
60 VDC, 1 ADC resistive	1×10^5 cycles



Note Relays are field replaceable. Refer to the **NI Switches Help** at ni.com/manuals for more information about replacing a failed relay.

Physical Characteristics

Relay type	Electromechanical, non-latching
Relay contact material	Palladium-ruthenium, gold covered
Front panel connector	160 DIN 41612, 160 positions, male
Power requirement	
PXI Express	
12 V	20 W
3.3 V	3.4 W
Dimensions (L × W × H)	3U, one slot, PXI/cPCI module, PXI Express compatible 21.6 cm × 2.0 cm × 13.0 cm (8.5 in. × 0.8 in. × 5.1 in.)

Weight	230 g (8.1 oz)
--------	----------------

Environment

Maximum altitude	2,000 m (800 mbar) (at 25 °C ambient temperature)
Pollution Degree	2

Indoor use only.

Operating Environment

Ambient temperature range	0 °C to 40 °C
Relative humidity range	10% to 90%, noncondensing

Storage Environment

Ambient temperature range	-40 °C to 71 °C
Relative humidity range	5% to 95%, noncondensing

Shock and Vibration

Operating shock	30 g peak, half-sine, 11 ms pulse
Random vibration	
Operating	5 Hz to 500 Hz, 0.3 grms

Nonoperating

5 Hz to 500 Hz, 2.4 grms

Diagrams

The following figure shows the PXIe-2525 power-on state.

Figure 1. PXIe-2525 Power-On State

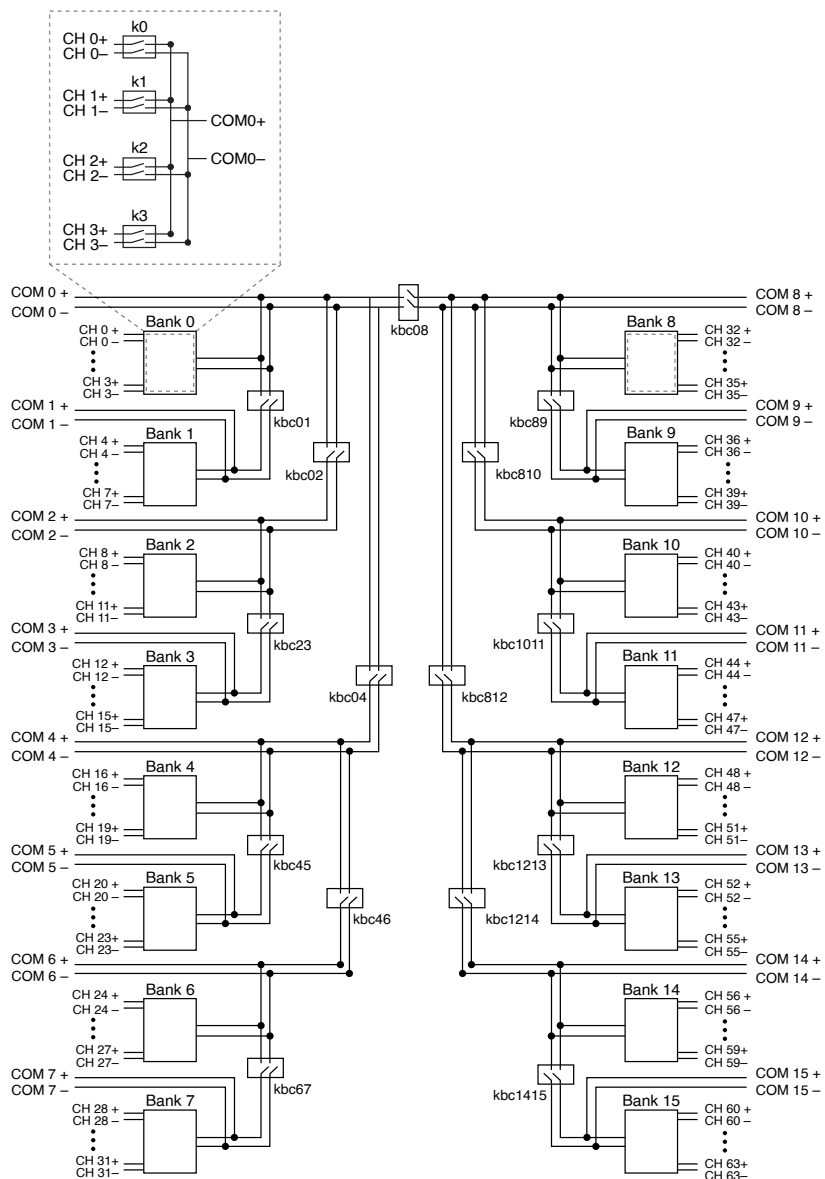

The following figure shows the PXIe-2525 connector pinout.

Figure 2. PXIe-2525 Connector Pinout

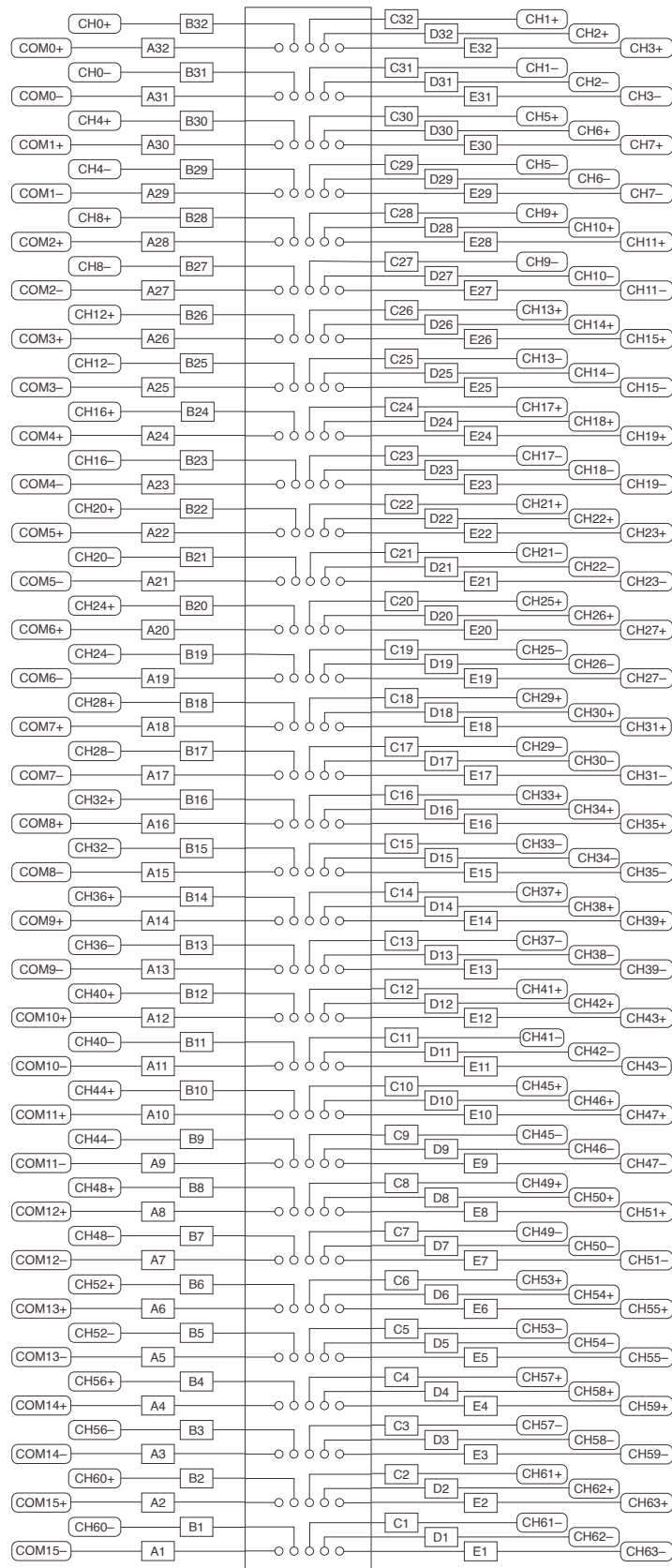

Accessories

Table 1. NI Accessories for the PXIe-2525

Accessory	Part Number
DIN160 to 50-pin D-SUB switch cable, 1 m	782417-03
DIN160 to DIN160 switch cable, 1 m	782417-02
DIN160 to bare wire switch cable, 1 m	782417-01
Relay replacement kit for IME02TS Relays	782461-10

Compliance and Certifications

Safety Compliance Standards

This product is designed to meet the requirements of the following electrical equipment safety standards for measurement, control, and laboratory use:

- IEC 61010-1, EN 61010-1
- UL 61010-1, CSA C22.2 No. 61010-1



Note For safety certifications, refer to the product label or the [Product Certifications and Declarations](#) section.

Electromagnetic Compatibility

This product meets the requirements of the following EMC standards for electrical equipment for measurement, control, and laboratory use:

- EN 61326-1 (IEC 61326-1): Class A emissions; Basic immunity
- EN 55011 (CISPR 11): Group 1, Class A emissions
- EN 55022 (CISPR 22): Class A emissions
- EN 55024 (CISPR 24): Immunity
- AS/NZS CISPR 11: Group 1, Class A emissions
- AS/NZS CISPR 22: Class A emissions
- FCC 47 CFR Part 15B: Class A emissions

- ICES-001: Class A emissions



Note In the United States (per FCC 47 CFR), Class A equipment is intended for use in commercial, light-industrial, and heavy-industrial locations. In Europe, Canada, Australia, and New Zealand (per CISPR 11), Class A equipment is intended for use only in heavy-industrial locations.



Note Group 1 equipment (per CISPR 11) is any industrial, scientific, or medical equipment that does not intentionally generate radio frequency energy for the treatment of material or inspection/analysis purposes.



Note For EMC declarations, certifications, and additional information, refer to the [Product Certifications and Declarations](#) section.

Product Certifications and Declarations

Refer to the product Declaration of Conformity (DoC) for additional regulatory compliance information. To obtain product certifications and the DoC for NI products, visit ni.com/product-certifications, search by model number, and click the appropriate link.

Environmental Management

NI is committed to designing and manufacturing products in an environmentally responsible manner. NI recognizes that eliminating certain hazardous substances from our products is beneficial to the environment and to NI customers.

For additional environmental information, refer to the **Engineering a Healthy Planet** web page at ni.com/environment. This page contains the environmental regulations and directives with which NI complies, as well as other environmental information not included in this document.

EU and UK Customers

-  Waste Electrical and Electronic Equipment (WEEE)—At the end of the product life cycle, all NI products must be disposed of according to local laws and regulations. For more information about how to recycle NI products in your region, visit ni.com/environment/weee.

电子信息产品污染控制管理办法 (中国 RoHS)

-  中国 RoHS— NI 符合中国电子信息产品中限制使用某些有害物质指令(RoHS)。关于 NI 中国 RoHS 合规性信息，请登录 ni.com/environment/rohs_china。(For information about China RoHS compliance, go to ni.com/environment/rohs_china.)