NI-5751/5751B

2022-07-11



Contents

NI 5751/5751B Getting Started Guide.	3
Electromagnetic Compatibility Guidelines.	3
FlexRIO Documentation.	4
Verifying the System Requirements.	5
Compatibility with FPGA Modules and Controllers for FlexRIO.	6
Accessories.	6
Unpacking.	7
Preparing the Environment.	8
Confirming that Measurement & Automation Explorer (MAX) Recognizes the Device.	8
Installing the NI 5751/5751B.	9
Cables.	9
Front Panel and Connector Pinouts.	9
Pinout and Signal Information.	10
Clocking.	12
Block Diagram.	13
Component-Level Intellectual Property (CLIP).	14
NI 5751 CLIP.	15
Where to Go Next.	16
Worldwide Support and Services.	16

NI 5751/5751B Getting Started Guide



Note Before you begin, complete the software and hardware installation instructions in your FlexRIO FPGA getting started guide or controller for FlexRIO getting started guide.



Caution Using the NI 5751/5751B in a manner not described in this document may impair the protection the NI 5751/5751B provides.

The NI 5751/5751B is a 50 MS/s, 14-bit high-speed digitizer adapter module designed to work in conjunction with FlexRIO FPGA modules and controllers for FlexRIO. The NI 5751/5751B features 16 analog input channels and 8 bidirectional digital I/O channels.

This document explains how to install and configure the NI 5751/5751B.

The **NI 5751B** variant is compatible with all FlexRIO FPGA modules and controllers for FlexRIO. The **NI 5751** variant is compatible with the NI PXI-795xR and NI PXIe-796xR FPGA modules only.



Note NI 5751R refers to the combination of your NI 5751/5751B adapter module and either a FlexRIO FPGA module or a controller for FlexRIO. **NI 5751/5751B** refers to your adapter module only.

Electromagnetic Compatibility Guidelines

This product was tested and complies with the regulatory requirements and limits for electromagnetic compatibility (EMC) stated in the product specifications. These requirements and limits are designed to provide reasonable protection against harmful interference when the product is operated in the intended operational electromagnetic environment.

This product is intended for use in industrial locations. However, harmful interference may occur in some installations, when the product is connected to a peripheral device or test object, or if the product is used in residential or

commercial areas. To minimize interference with radio and television reception and prevent unacceptable performance degradation, install and use this product in strict accordance with the instructions in the product documentation.

Furthermore, any modifications to the product not expressly approved by National Instruments could void your authority to operate it under your local regulatory rules.



Caution To ensure the specified EMC performance, operate this product only with shielded cables and accessories.



Caution To ensure the specified EMC performance, you must install PXI EMC Filler Panels, National Instruments part number 778700-01, in all open chassis slots. You can order a kit of six single slot EMC Filler Panels directly from NI by visiting ni.com.



Caution To ensure the specified EMC performance, the length of all I/O cables must be no longer than 30 m (100 ft).

FlexRIO Documentation

Document	Location	Description
Getting started guide for your FlexRIO FPGA module or controller for FlexRIO	Available from the Start menu and at ni.com/manuals .	Contains installation instructions for your FlexRIO system.
Specifications document for your FlexRIO FPGA module or controller for FlexRIO	Available from the Start menu and at ni.com/manuals .	Contains specifications for your FlexRIO FPGA module or controller for FlexRIO.
Getting started guide for your adapter module	Available from the Start menu and at ni.com/manuals .	Contains signal information, examples, and CLIP details for your adapter module.

Document	Location	Description
Specifications document for your adapter module	Available from the Start menu and at ni.com/manuals .	Contains specifications for your adapter module.
LabVIEW FPGA Module Help	Embedded in LabVIEW Help and at ni.com/manuals .	Contains information about the basic functionality of the LabVIEW FPGA Module.
Real-Time Module Help	Embedded in LabVIEW Help and at ni.com/manuals .	Contains information about real-time programming concepts, step-by-step instructions for using LabVIEW with the Real-Time Module, reference information about Real-Time Module VIs and functions, and information about LabVIEW features on real-time operating systems.
FlexRIO Help	Available from the Start menu and at ni.com/manuals .	Contains information about the FPGA module front panel connectors and I/O, controller for FlexRIO front panel connectors and I/O, programming instructions, and adapter module component-level IP (CLIP).
FlexRIO Adapter Module Development Kit User Manual	Available from the Start menu at Start » All Programs » National Instruments » NI FlexRIO » NI FlexRIO Adapter Module Development Kit » Documentation.	Contains information about how to create custom adapter modules for use with FlexRIO FPGA modules.
LabVIEW Examples	Available in NI Example Finder. In LabVIEW, click Help » Find Examples » Hardware Input and Output » FlexRIO.	Contains examples of how to run FPGA VIs and Host VIs on your device.
IPNet	Located at ni.com/ipnet .	Contains LabVIEW FPGA functions and intellectual property to share.
FlexRIO product page	Located at ni.com/flexrio .	Contains product information and data sheets for FlexRIO devices.

Table 1. FlexRIO Documentation Locations and Descriptions

Verifying the System Requirements

To use the NI 5751/5751B, your system must meet certain requirements. For more information about minimum system requirements, recommended system, and supported application development environments (ADEs), refer to the readme, which is available on the software media or online at ni.com/updates.

Compatibility with FPGA Modules and Controllers for FlexRIO

The NI 5751B variant is compatible with all FlexRIO FPGA modules and controllers for FlexRIO; however, the NI 5751 variant is only compatible with NI PXI-795xR and NI PXIe-796xR modules. The following table lists each adapter module's compatibility with FlexRIO FPGA modules and controllers for FlexRIO.

	NI PXI-795xR	NI PXIe-796xR	NI PXIe-797xR	NI-793xR
NI 5751	Yes	Yes	No	No
NI 5751B	Yes	Yes	Yes	Yes

Table 2. Adapter Module Compatibility

Accessories

NI SMB-2147/2148 devices are shielded signal accessories for NI 5751/5751B adapter modules. NI SMB-2147/2148 accessories provide easy connections to other devices for testing and debugging. For more information about these accessories, refer to the **NI SMB-2145/2146/2147/2148 User Guide**. The following figure shows a typical setup of the NI 5751/5751B with the NI SMB-2147 and NI SMB-2148 signal accessories.

Figure 1. NI 5751/5751B with NI SMB-2147 and NI SMB-2148 Signal Accessories

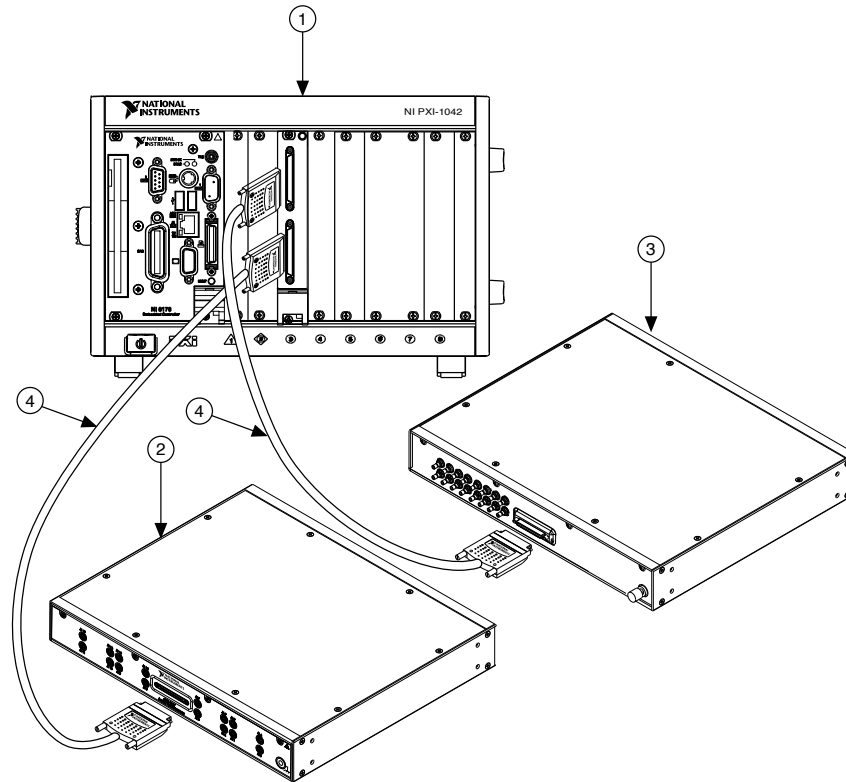

1. PXI Chassis with FlexRIO FPGA and adapter module
2. NI SMB-2147
3. NI SMB-2148
4. SHC68-C68-D4 Cable Assemblies

Unpacking



Caution To prevent ESD from damaging the devices, ground yourself using a grounding strap or by holding a grounded object, such as your computer chassis.

1. Touch the antistatic package to a metal part of the computer chassis.
2. Remove each module from the package and inspect it for loose components or any other sign of damage.



Caution Never touch the exposed pins of connectors.



Note Do not install a device if it appears damaged in any way.

- Unpack any other items and documentation from the kit.

Store the devices in the antistatic package when they are not in use.

Preparing the Environment

Ensure that the environment you are using the NI 5751/5751B in meets the following specifications.

Operating temperature (IEC 60068-2-1, IEC 60068-2-2)	0 °C to 55 °C
Operating humidity (IEC 60068-2-56)	10% to 90% RH, noncondensing
Pollution Degree	2
Maximum altitude	2,000 m at 25 °C ambient temperature

Indoor use only.



Note Refer to the **NI 5751/5751B Specifications** at ni.com/manuals for complete specifications.



Caution Clean the hardware with a soft, nonmetallic brush. Make sure that the hardware is completely dry and free from contaminants before returning it to service.

Confirming that Measurement & Automation Explorer (MAX) Recognizes the Device

Use Measurement & Automation Explorer (MAX) to configure your NI hardware. MAX informs other programs about which devices reside in the system and how they are configured. MAX is automatically installed with FlexRIO Support.

1. Launch MAX by navigating to Start » All Programs » National Instruments » NI MAX or by clicking the NI MAX desktop icon.
2. In the Configuration pane, double-click Devices and Interfaces to see the list of installed devices. Installed devices appear under the name of their associated chassis.
3. (PXI and PXI Express devices only) Expand your Chassis tree item. MAX lists all devices installed in the chassis. Your default device names may vary.



Note If you do not see your hardware listed, press <F5> to refresh the list of installed devices. If the device is still not listed, power off the system, ensure the device is correctly installed, and restart.

4. (Controllers for FlexRIO only) Your device appears under the Remote Devices section.

Installing the NI 5751/5751B

Refer to the getting started guide for your FlexRIO FPGA module or Controller for FlexRIO for instructions about how to install your FlexRIO system, including the NI 5751/5751B.

Cables

NI recommends using the SHC68-C68-D4 cable (part number 196275A-01) with the NI 5751/5751B. This cable connects directly to the analog and digital connectors on the NI 5751/5751B.

Front Panel and Connector Pinouts

The following figure shows the front panel connectors for the NI 5751/5751B.

Device Front Panel	Connector	Description
	DI 0-7/DO-07	Digital input terminals (DI 0-7) and digital output terminals (DO 0-7)

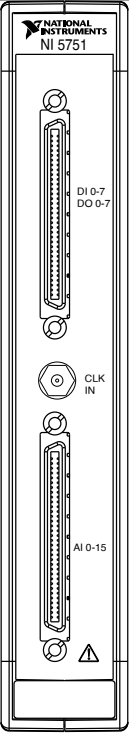
Device Front Panel	Connector	Description
	CLK IN	Sample Clock input
	AI 0-15	Single-ended analog input channels



Caution To avoid permanent damage to the NI 5751/5751B, disconnect all signals connected to the NI 5751/5751B before powering down the module, and connect signals only after the adapter module has been powered on by the FlexRIO FPGA module or controller for FlexRIO.



Caution Connections that exceed any of the maximum ratings of any connector on the NI 5751/5751B can damage the device and the chassis. NI is not liable for any damage resulting from such connections.

Pinout and Signal Information

The following figure shows the pinout for the VHDCI connector.

Figure 2. NI 5751 Digital Connector Pinout

GND	68	34	GND
GND	67	33	GND
GND	66	32	GND
DO 0	65	31	DO 1
GND	64	30	GND
DO 2	63	29	DO 3
GND	62	28	GND
DO 4	61	27	DO 5
GND	60	26	GND
DO 6	59	25	DO 7
GND	58	24	GND
DI 0	57	23	DI 1
GND	56	22	GND
DI 2	55	21	DI 3
GND	54	20	GND
DI 4	53	19	DI 5
GND	52	18	GND
DI 6	51	17	DI 7
GND	50	16	GND
GND	49	15	GND
GND	48	14	GND
GND	47	13	GND
GND	46	12	GND
GND	45	11	GND
GND	44	10	GND
GND	43	9	GND
GND	42	8	GND
GND	41	7	GND
GND	40	6	GND
GND	39	5	GND
GND	38	4	GND
GND	37	3	GND
GND	36	2	GND
GND	35	1	GND

The following figure shows the pinout for the analog connector on the front panel of the NI 5751/5751B.

Figure 3. NI 5751 Analog Input CH 0 to CH 15

GND	68	34	GND
GND	67	33	GND
GND	66	32	GND
AI 15	65	31	GND
GND	64	30	GND
GND	63	29	AI 14
GND	62	28	GND
AI 13	61	27	GND
GND	60	26	GND
GND	59	25	AI 12
GND	58	24	GND
AI 11	57	23	GND
GND	56	22	GND
GND	55	21	AI 10
GND	54	20	GND
AI 9	53	19	GND
GND	52	18	GND
GND	51	17	AI 8
GND	50	16	GND
AI 7	49	15	GND
GND	48	14	GND
GND	47	13	AI 6
GND	46	12	GND
AI 5	45	11	GND
GND	44	10	GND
GND	43	9	AI 4
GND	42	8	GND
AI 3	41	7	GND
GND	40	6	GND
GND	39	5	AI 2
GND	38	4	GND
AI 1	37	3	GND
GND	36	2	GND
GND	35	1	AI 0

Clocking

The NI 5751/5751B clock source controls the sample rate and other timing functions on the device. The following table contains information about the possible NI 5751/5751B clock sources.

Clock	Notes	Frequency Range
50 MHz onboard clock	—	30 MHz to 50 MHz

Clock	Notes	Frequency Range
Sync Clock (DStarA)	<p>Sync Clock (DStarA) is only available on NI PXI Express FlexRIO FPGA modules (such as the NI PXIe-796xR). DStarA is not available on NI-793xR controllers for FlexRIO or NI PXI FlexRIO FPGA modules (such as the NI PXI-795xR). On PXI Express modules, Sync Clock is driven by the DStarA from the PXI/PXIe backplane.</p> <p>If you change the frequency of Sync Clock (DStarA) or CLK IN (when used as the Sample Clock), you must assert Force Initialization.</p>	
CLK IN (front panel SMB)	<p>If you change the frequency of Sync Clock (DStarA) or CLK IN (when used as the Sample Clock), you must assert Force Initialization. For more information, refer to the FlexRIO Help.</p>	

Table 3. Sample Clock Sources

Related information

- <http://www.ni.com/manuals/>

Block Diagram

The following figure shows the NI 5751/5751B block diagram and signal flow.

Figure 1. NI 5751 Hardware Block Diagram

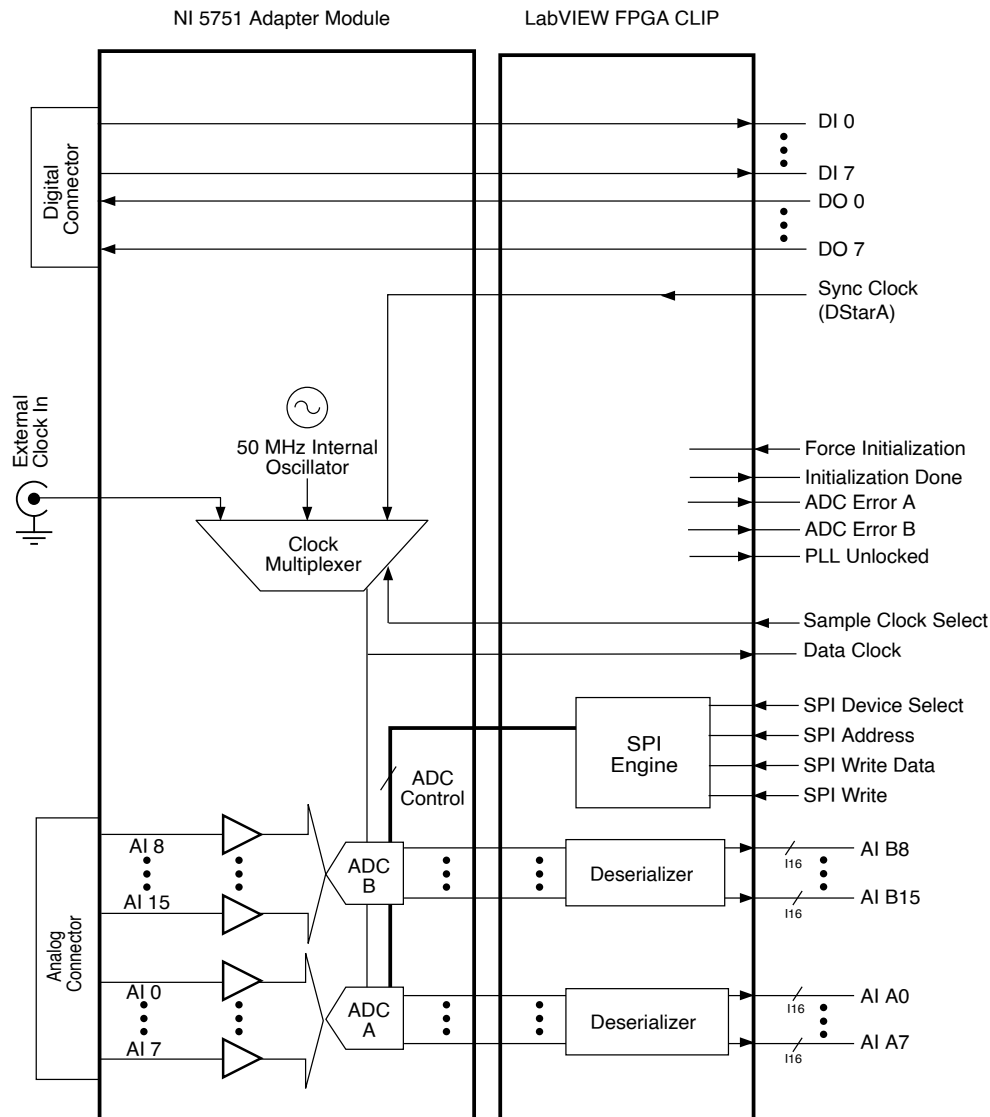

Component-Level Intellectual Property (CLIP)

The LabVIEW FPGA Module includes component-level intellectual property (CLIP) for HDL IP integration. FlexRIO devices support two types of CLIP: user-defined and socketed.

- **User-defined CLIP** allows you to insert HDL IP into an FPGA target, enabling VHDL code to communicate directly with an FPGA VI.

- **Socketed CLIP** provides the same IP integration of the user-defined CLIP, but it also allows the CLIP to communicate directly with circuitry external to the FPGA. Adapter module socketed CLIP allows your IP to communicate directly with both the FPGA VI and the external adapter module connector interface.

The FlexRIO adapter module ships with socketed CLIP items that add module I/O to the LabVIEW project.

NI 5751 CLIP

The NI 5751/5751B ships with the following CLIP items:

1. **NI 5751 CLIP**—The NI 5751 CLIP provides access to 16 analog input channels, eight digital input lines, and eight digital output lines. This CLIP also contains a SPI interface to program the ADC registers.
In the NI 5751 CLIP, each Sample Clock cycle generates a sample from the analog input channels. Three clock sources are available and are selectable using the Sample Clock Select control. The default clock source is the 50 MHz onboard oscillator. Other clock sources available are DStarA through IOModSyncClock and an external clock through the front panel SMB connector. This CLIP only supports external Sample Clock rates from 30 MHz to 50 MHz. Each 14-bit sample is output to LabVIEW as an I16 data type. The 14-bit data is left-justified and padded with two zeros in the LSBs. The data is clocked out of the CLIP on the Data Clock signal.
2. **NI 5751 Multidevice Synchronization CLIP**—The NI 5751 Multidevice Synchronization CLIP provides access to 16 analog input channels, eight digital input lines, and eight digital output lines. This CLIP also contains a SPI interface to program the ADC registers. Use this CLIP for applications that require synchronization across multiple NI 5751 modules.
In the NI 5751 Multidevice Synchronization CLIP, each Sample Clock cycle generates a sample from the analog input channels. DStarA is the only Sample Clock that is routed. This CLIP only supports external Sample Clock rates from 30 MHz to 50 MHz. Each 14-bit sample is output to LabVIEW as an I16 data type. The 14-bit data is left-justified and padded with two zeros in the LSBs. DStarA is required to be routed to the CLIP from LabVIEW FPGA. The data is clocked out of the CLIP on the Data Clock signal.

Related information

- <http://www.ni.com/manuals/>

Where to Go Next

Refer to the following figure for information about other product tasks and associated resources for those tasks.

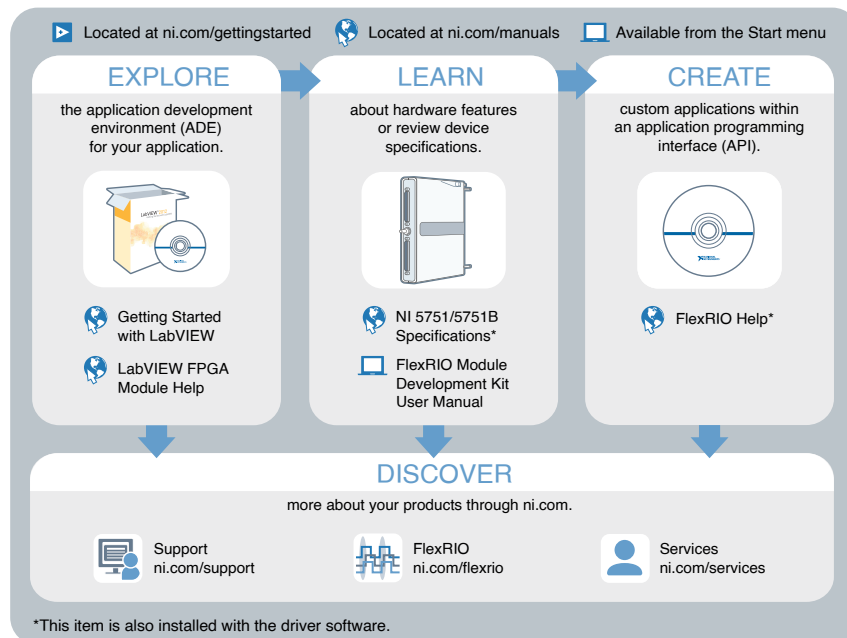

Worldwide Support and Services

The NI website is your complete resource for technical support. At ni.com/support, you have access to everything from troubleshooting and application development self-help resources to email and phone assistance from NI Application Engineers.

Visit ni.com/services for NI Factory Installation Services, repairs, extended warranty, and other services.

Visit ni.com/register to register your NI product. Product registration facilitates technical support and ensures that you receive important information updates from NI.

A Declaration of Conformity (DoC) is our claim of compliance with the Council of the European Communities using the manufacturer's declaration of conformity. This system affords the user protection for electromagnetic compatibility (EMC) and product safety. You can obtain the DoC for your product by visiting ni.com/certification. If your product supports calibration, you can obtain the calibration certificate for your product at ni.com/calibration.

NI corporate headquarters is located at 11500 North Mopac Expressway, Austin, Texas, 78759-3504. NI also has offices located around the world. For telephone support in the United States, create your service request at ni.com/support or dial 1 866 ASK MYNI (275 6964). For telephone support outside the United States, visit the **Worldwide Offices** section of ni.com/niglobal to access the branch office websites, which provide up-to-date contact information, support phone numbers, email addresses, and current events.