

---

# SCB-12 Safety, Environmental, and Regulatory Information

---

2022-07-11



# Contents

SCB-12 Purpose and Introduction..... 3

# SCB-12 Purpose and Introduction

This document provides safety, environmental, and regulatory information, connection instructions, and specifications for the SCB-12.

## Icon Definitions

|   |   |
|---|---|
| ⓘ | Notice Take precautions to avoid data loss, loss of signal integrity, degradation of performance, or damage to the model.   |
| ⚠ | Caution Take precautions to avoid injury. Consult the model documentation for cautionary statements when you see this icon printed on the model. Cautionary statements are localized into French for compliance with Canadian requirements. |

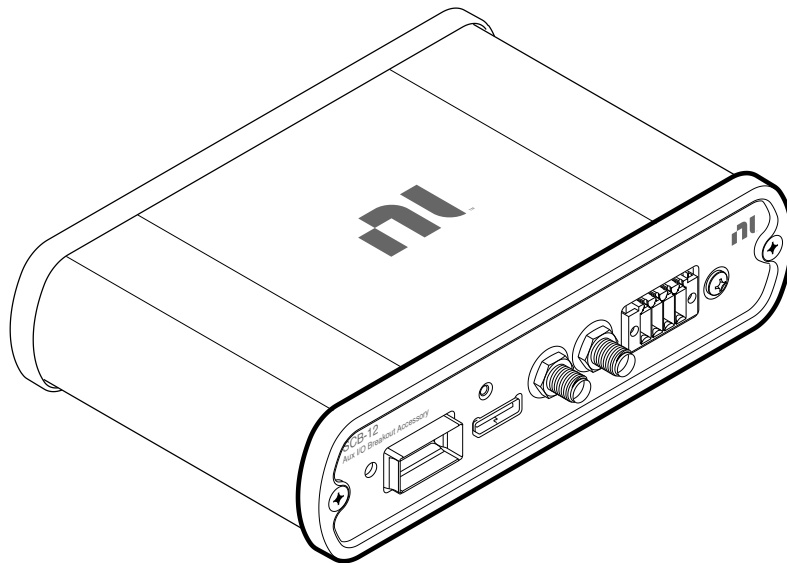

## Safety Guidelines



Caution Observe all instructions and cautions in the user documentation. Using the product in a manner not specified can damage the product and

compromise the built-in safety protection. Return damaged products to NI for repair.



**Attention** Suivez toutes les instructions et respectez toutes les mises en garde de la documentation d'utilisation. L'utilisation du produit de toute autre façon que celle spécifiée risque de l'endommager et de compromettre la protection de sécurité intégrée. Renvoyez les produits endommagés à NI pour réparation.

## Safety Cautions



**Caution** All wiring must be insulated for the highest voltage used.



**Attention** Tout le câblage doit être isolé pour la plus haute tension utilisée.

## Safety Voltages



**Notice** Connect only voltages that are below the limits described in the specifications document for the FlexRIO module you will connect to the SCB-12. You can search for specification documents by product name at [ni.com/manuals](http://ni.com/manuals).



**Notice** When you have finished using the SCB-12, power off any external signals connected to the SCB-12 before you power off your computer.

## Measurement Category I



**Caution** Do not connect the product to signals or use for measurements within Measurement Categories II, III, or IV.



**Attention** Ne pas connecter le produit à des signaux dans les catégories de mesure II, III ou IV et ne pas l'utiliser pour effectuer des mesures dans ces catégories.

Measurement Category I is for measurements performed on circuits not directly connected to the electrical distribution system referred to as **MAINS** voltage. MAINS is a hazardous live electrical supply system that powers equipment. This category is for measurements of voltages from specially protected secondary circuits. Such voltage measurements include signal levels, special equipment, limited-energy parts of equipment, circuits powered by regulated low-voltage sources, and electronics.



**Note** Measurement Categories CAT I and CAT O are equivalent. These test and measurement circuits are for other circuits not intended for direct connection to the MAINS building installations of Measurement Categories CAT II, CAT III, or CAT IV.

## Safety Standards

This product is designed to meet the requirements of the following electrical equipment safety standards for measurement, control, and laboratory use:

- IEC 61010-1, EN 61010-1
- UL 61010-1, CSA C22.2 No. 61010-1

## EMC Guidelines

This product was tested and complies with the regulatory requirements and limits for electromagnetic compatibility (EMC) stated in the product specifications. These requirements and limits provide reasonable protection against harmful interference when the product is operated in the intended operational electromagnetic environment.

This product is intended for use in industrial locations. However, harmful interference may occur in some installations, when the product is connected to

a peripheral device or test object, or if the product is used in residential or commercial areas. To minimize interference with radio and television reception and prevent unacceptable performance degradation, install and use this product in strict accordance with the instructions in the product documentation.

Furthermore, any changes or modifications to the product not expressly approved by NI could void your authority to operate it under your local regulatory rules.



**Notice** Operate this product only with shielded cables and accessories. Do not use unshielded cables or accessories unless they are installed in a shielded enclosure with properly designed and shielded input/output ports and connected to the product using a shielded cable. If unshielded cables or accessories are not properly installed and shielded, the EMC specifications for the product are no longer guaranteed.

## Electromagnetic Compatibility Standards

This product meets the requirements of the following EMC standards for electrical equipment for measurement, control, and laboratory use:

- EN 61326-1 (IEC 61326-1): Class A emissions; Basic immunity
- EN 55011 (CISPR 11): Group 1, Class A emissions
- AS/NZS CISPR 11: Group 1, Class A emissions



**Note** In the United States (per FCC 47 CFR), Class A equipment is intended for use in commercial, light-industrial, and heavy-industrial locations. In Europe, Canada, Australia, and New Zealand (per CISPR 11), Class A equipment is intended for use only in heavy-industrial locations.



**Note** Group 1 equipment (per CISPR 11) is any industrial, scientific, or medical equipment that does not intentionally generate radio frequency energy for the treatment of material or inspection/analysis purposes.



Note For EMC declarations, certifications, and additional information, refer to the [Product Certifications and Declarations](#) section.

## What You Need to Get Started

Figure 1. SCB-12 Kit Contents

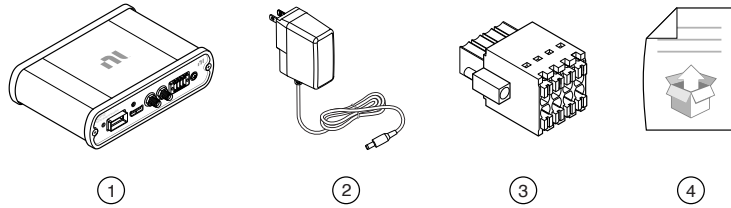

1. SCB-12
2. External Power Supply
3. 8-Pin Female Connector
4. SCB-12 User Guide

## Additional Required Items

- FlexRIO module with compatible connectors
- Molex™ Nano-Pitch I/O™ cable

## Breakout Cable Options

- SMA cable(s)
- Shielded, multiconductor cable with 16 AWG to 26 AWG wire
- An electrical or optical QSFP or QSFP+ cable

| Cable  | Power Class | Vendor     | Part Number | Key Specification                           |
|--|-------------|------------|-------------|---|
| Active Optical Cable (Generic) 1 m (3 ft) 40 G QSFP+ | 1           | FiberStore | QSFP-A001   | Electrical rate of 0.5 Gb/s to 10.3125 Gb/s |

| Cable  | Power Class | Vendor   | Part Number   | Key Specification                                     |
|--|-------------|----------|---------------|---|
| Active Fiber Cable<br>Ethernet 10 m (30 ft)<br>40 GbE QSFP | 1           | Mellanox | MC2210310-010 | Optical rate of<br>1 Gb/s to 10.3125 Gb/s<br>±100 ppm |

Table 1. Recommended QSFP or QSFP+ Cables



**Note** For optimal cable performance, adjust the TX settings in your bitfile according to the manufacturer's cable specifications.

## Accessories

- 2.5 mm flathead screwdriver
- #2 Phillips screwdriver
- Wire insulation stripper
- Wire cutters
- Strain relief assembly for the Nano-Pitch cable



**Note** The strain relief assembly ships with Molex Nano-Pitch cables purchased from NI. To ensure an uninterrupted connection, NI recommends, but does not require, use of the strain relief assembly.

- NI 9913 DIN rail mounting kit (NI part number 781740-01)

## Preparing the FlexRIO Module

1. Install and configure the FlexRIO module you want to connect to the SCB-12.



**Note** For installation and configuration instructions, refer to the **Getting Started Guide** for your product, accessible at [ni.com/manuals](http://ni.com/manuals).

2. Connect the Molex™ Nano-Pitch I/O™ cable to your FlexRIO module.





**Note** For DIO signal specifications, refer to the specifications document for the FlexRIO module you want to connect to the SCB-12. Search for specification documents by product name at [ni.com/manuals](http://ni.com/manuals).

## Connecting to the SCB-12

The SCB-12 enables access to DIO signals from a Molex™ Nano-Pitch I/O™ cable through other common connectors. To use the SCB-12, you must first connect a Molex™ Nano-Pitch I/O™ cable to your FlexRIO module.

Figure 2. SCB-12 Front Panel

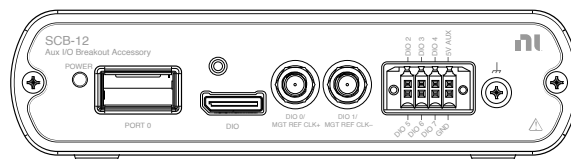

## Connecting to the Molex Nano-Pitch I/O DIO Port

1. Connect the Molex™ Nano-Pitch I/O™ cable to the port labeled DIO.



**Notice** Using signal voltages outside of the range specified for the FlexRIO module you connect to the SCB-12 could damage the SCB-12 and any instruments connected to it. For maximum voltage specifications, refer to the documentation for the connected hardware. NI is not liable for any damage resulting from using voltages outside of the recommended range.

2. To ensure the Molex™ Nano-Pitch I/O™ cable stays inserted, slide the strain relief assembly over the Molex™ Nano-Pitch I/O™ cable body and screw it into position in the front panel.



**Note** The strain relief assembly ships with Molex Nano-Pitch cables purchased from NI. To ensure an uninterrupted connection, NI

recommends, but does not require, the use of the strain relief assembly.

Figure 4. Connecting the Strain Relief Assembly

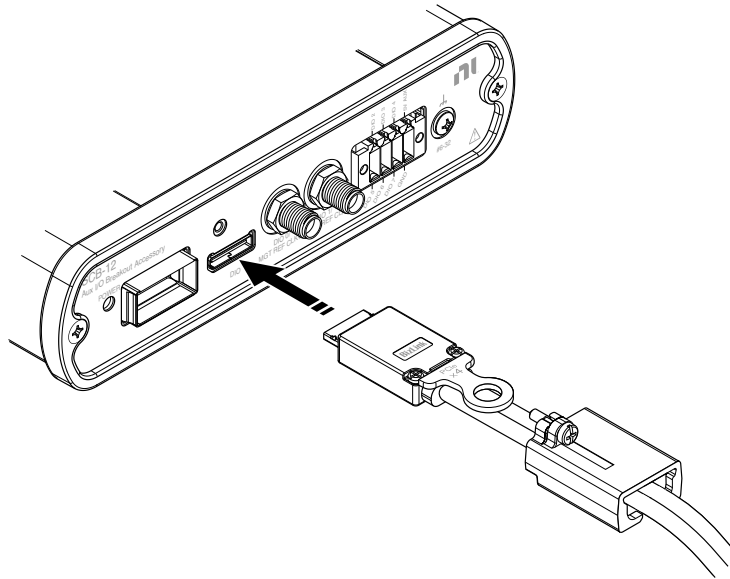

## Connecting to the DIO/MGT REF CLK Ports

Screw a standard SMA cable into one or both of the DIO/MGT REF CLK ports.



**Notice** Using signal voltages outside of the range specified for the FlexRIO module you connect to the SCB-12 could damage the SCB-12 and any instruments connected to it. For maximum voltage specifications, refer to the documentation for the connected hardware. NI is not liable for any damage resulting from using voltages outside of the recommended range.



**Tip** To ease cable installation difficulties when connecting to multiple ports, NI recommends connecting to the DIO/MGT REF CLK ports first.

## Connecting to the DIO Spring Terminals

1. Strip and prepare the wires to connect to the DIO signals you want to access.



**Notice** To ensure the EMC performance specified for the connected hardware, NI recommends using a multiconductor cable with an overall shield to connect to spring terminals. Terminate the cable shield to one of the PCB mounting screws.

2. Align the 8-pin female connector included in your kit to the DIO spring terminals and the retention screw holes on the SCB-12 front panel. Use a 2.5 mm flathead screwdriver to loosely screw the attached retention screws into the front panel.
3. Use the flathead screwdriver to open the spring terminals and insert the prepared wires.
4. After inserting the wires, use your thumb to press firmly on the 8-pin female connector until it fully seats into the front panel. Use the flathead screwdriver to tighten the retention screws.

Figure 4. Connecting the 8-Pin Female Connector to the DIO Spring Terminals

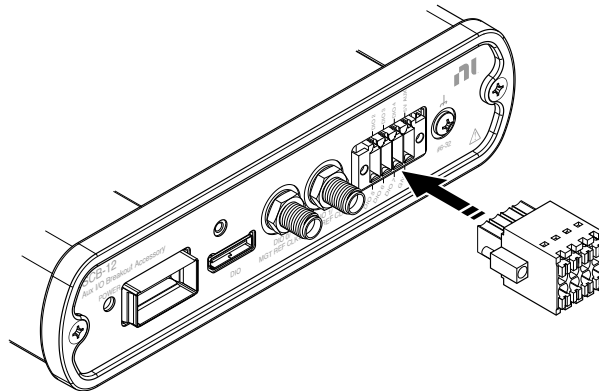

## Connecting to PORT 0

Before you begin, refer to [External Power Requirements](#) for maximum voltage and power specifications.

1. To connect an optical QSFP or QSFP+ cable at PORT 0, first connect the external power supply included in your kit to the power connector on the back panel of the SCB-12.

Figure 5. SCB-12 Back Panel

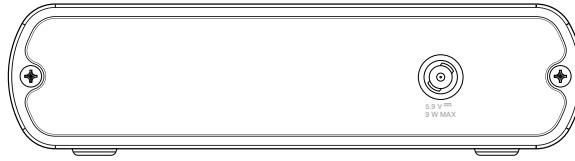

2. Plug the external power supply into AC power.



**Note** Electrical QSFP or QSFP+ cables do not require the external power supply included in your kit.



**Note** You must use the external power supply included in the SCB-12 kit, NI part number 723537-01, to power an optical QSFP or QSFP+ cable.

3. The power LED on the SCB-12 front panel indicates a connection to external power. After connecting the external power supply included in your kit, ensure the power LED is lit.
4. Connect your optical or electrical QSFP or QSFP+ cable to PORT 0.



**Note** Refer to [What You Need to Get Started](#) for recommended QSFP and QSFP+ cable specifications.

## Using the Optional Ground Lug

The SCB-12 provides an optional ground lug on the front panel.



**Notice** To mitigate ground loops or conducted noise that may impair the functionality of the SCB-12, attach a thick wire or braided cable from the system ground to the ground lug on the SCB-12 front panel.

## Mounting the SCB-12 on a DIN Rail with the NI 9913 Mounting Kit

The NI 9913 DIN rail mounting kit contains a clip for mounting the SCB-12 on a standard 35 mm DIN rail. The four holes on the bottom of the SCB-12 allow it to be mounted in multiple orientations.

1. Using a #2 Phillips screwdriver and the two FLH #6-32 × 5/16" screws included in the NI 9913 DIN rail mounting kit, fasten the DIN rail clip to the SCB-12.



**Note** Use only the screws provided in the DIN rail kit. Using longer screws may damage the SCB-12.

Figure 6. DIN Rail Clip Installation

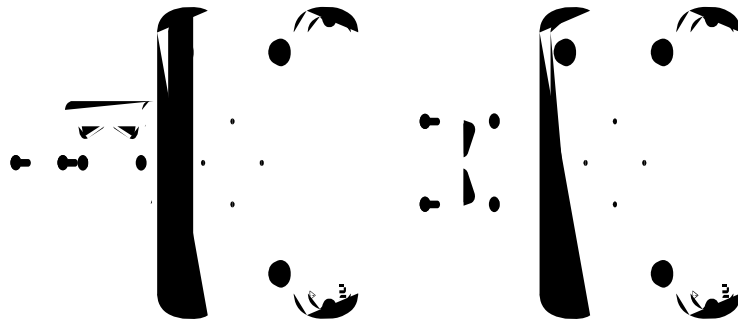

2. Clip the SCB-12 onto the DIN rail with the larger lip of the DIN rail clip positioned up.

Figure 7. DIN Rail Clip Parts Locator Diagram

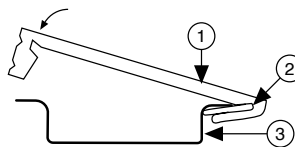

1. DIN Rail Clip
2. DIN Rail Spring
3. DIN Rail

## Specifications

### DIO Signal Specifications



**Note** For DIO signal specifications, refer to the specifications document for the FlexRIO module you want to connect to the SCB-12. Search for specification documents by product name at [ni.com/manuals](http://ni.com/manuals).

### MGT Specifications

|                           |                |
|---------------------------|----------------|
| Line rate                 | 10.3125 Gb/s   |
| <b>Power capabilities</b> |                |
| Optical cable             | Class 1, 1.5 W |
| Electrical cable          | Not applicable |

### External Power Requirements

|   |  |
|---|--|
| Voltage input range                           | 5.9 V DC                                   |
| Maximum power consumption                     | 9 W, maximum                               |
| External power supply for optical cable power | Included in kit (NI part number 723537-01) |

### Physical Characteristics

|            |  |
|------------|--|
| Dimensions | 10.3 cm × 14.3 cm × 3.8 cm (4.1 in. × 5.6 in. × 1.5 in.) |
| Weight     | 400 g (14.1 oz)  |

## Environment

|                  |   |
|------------------|---|
| Maximum altitude | 2,000 m (800 mbar) (at 25 °C ambient temperature) |
| Pollution Degree | 2   |

Indoor use only.

## Operating Environment

|                           |                           |
|---------------------------|---------------------------|
| Ambient temperature range | 0 °C to 55 °C             |
| Relative humidity range   | 10% to 90%, noncondensing |

## Storage Environment

|                           |                          |
|---------------------------|--------------------------|
| Ambient temperature range | -40 °C to 71 °C          |
| Relative humidity range   | 5% to 95%, noncondensing |

## Compliance and Certifications

### Product Certifications and Declarations

Refer to the product Declaration of Conformity (DoC) for additional regulatory compliance information. To obtain product certifications and the DoC for NI products, visit [ni.com/product-certifications](https://ni.com/product-certifications), search by model number, and click the appropriate link.

## Environmental Management

NI is committed to designing and manufacturing products in an environmentally responsible manner. NI recognizes that eliminating certain hazardous substances from our products is beneficial to the environment and to NI customers.

For additional environmental information, refer to the **Commitment to the Environment** web page at [ni.com/environment](https://ni.com/environment). This page contains the environmental regulations and directives with which NI complies, as well as other environmental information not included in this document.

## Waste Electrical and Electronic Equipment (WEEE)

**EU Customers** At the end of the product life cycle, all NI products must be disposed of according to local laws and regulations. For more information about how to recycle NI products in your region, visit [ni.com/environment/weee](https://ni.com/environment/weee).

## 电子信息产品污染控制管理办法 ( 中国 RoHS )

NI 符合中国电子信息产品中限制使用某些有害物质指令(RoHS)。关于 NI 中国 RoHS 合规性信息，请登录 [ni.com/environment/rohs\\_china](https://ni.com/environment/rohs_china)。(For information about China RoHS compliance, go to [ni.com/environment/rohs\\_china](https://ni.com/environment/rohs_china).)

## Worldwide Support and Services

The NI website is your complete resource for technical support. At [ni.com/support](https://ni.com/support), you have access to everything from troubleshooting and application development self-help resources to email and phone assistance from NI Application Engineers.

Visit [ni.com/services](https://ni.com/services) for information about the services NI offers.



Visit [ni.com/register](https://ni.com/register) to register your NI product. Product registration facilitates technical support and ensures that you receive important information updates from NI.

NI corporate headquarters is located at 11500 North Mopac Expressway, Austin, Texas, 78759-3504, USA. For up-to-date contact information for your location, visit [ni.com/contact](https://ni.com/contact).