

---

# NI-9351

# Features

---

2022-07-12



# Contents

C Series Functional Safety Manual. . . . .	4
C Series Functional Safety Systems. . . . .	4
Develop. . . . .	5
Deploy. . . . .	5
Runtime. . . . .	6
Functional Safety Overview. . . . .	6
FMEDA Assumptions. . . . .	7
Minimum Required Competency. . . . .	7
C Series Functional Safety Requirements. . . . .	8
Proof Test. . . . .	10
Non-Safety Functionality. . . . .	10
Installing Functional Safety Tools. . . . .	11
Installing Hardware. . . . .	11
Installing Software. . . . .	11
Developing a Functional Safety System. . . . .	12
Running the Safety Editor. . . . .	12
Creating a Functional Safety Project in LabVIEW. . . . .	13
Creating a Functional Safety Monitoring VI in LabVIEW. . . . .	14
Deploying a Functional Safety System. . . . .	15
Downloading User Programs. . . . .	15
Verifying User Programs. . . . .	17
Validating a Functional Safety System. . . . .	17
Functional Safety Hardware. . . . .	17
Module Independence. . . . .	17
Module Logic Solver (FPGA-based). . . . .	18
Module Operating Modes. . . . .	18
Fail-Safe Mode. . . . .	20
Power Down Mode. . . . .	21
Functional Safety Editor. . . . .	21
Module and Diagram Tab. . . . .	23
Build Number. . . . .	24
Auto Start. . . . .	25
I/O Configuration Table. . . . .	26

State Machine Diagram. . . . .	46
Saving and Compiling. . . . .	61
JSON Files. . . . .	62
Type Definitions. . . . .	62
JSON Definitions. . . . .	62
Semantic Definitions. . . . .	68
Safety System Response Time. . . . .	69
Calculating Safety System Response Times. . . . .	70
Fault Response Time. . . . .	71
Sensor Response Time. . . . .	72
Digital Input Signal Response Time. . . . .	72
Analog Input Signal Response Time. . . . .	74
Diagnostic Response Times. . . . .	74
Application Processing Time. . . . .	79
Output Signal Response Time. . . . .	79
Power Down Response Time. . . . .	80
Actuator Response Time. . . . .	80
Safety Response Time Specifications. . . . .	80
Diagnostics. . . . .	83
Fault Detection. . . . .	83
User-Configurable Digital Diagnostics. . . . .	89
User-Configurable Analog Diagnostics (NI 9351 Only). . . . .	98
Current Threshold Diagnostics. . . . .	103
Fault Latching. . . . .	109
Automatic Self-Diagnostics. . . . .	109
LED Diagnostics. . . . .	110
Finding Resources. . . . .	112
Updating Safety Software and Firmware. . . . .	114
C Series Functional Safety Firmware. . . . .	114
Known Issues for Firmware Versions. . . . .	115
NI Services. . . . .	117

# C Series Functional Safety Manual

This document provides information about developing, deploying, and running Functional Safety systems using C Series Functional Safety modules.

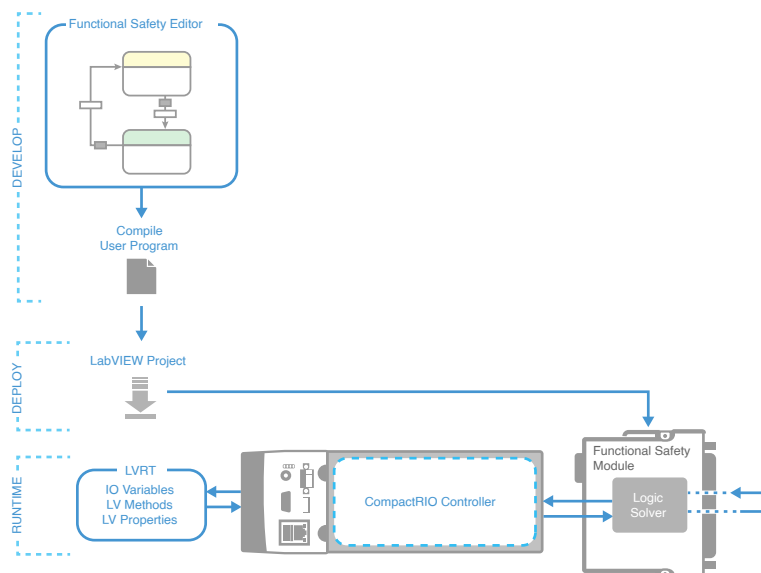
C Series Functional Safety modules include the NI 9350 and the NI 9351. You can identify C Series Functional Safety modules by the yellow enclosure, yellow backshell, and SIL certification mark.

This is the May 2018 release version of the C Series Functional Safety Manual. Refer to the following table for release version information.

Part Number	Release Date	Release Notes
377937A-01	September 2017	This is the initial release version. This version includes support for the NI 9350 and the Functional Safety Editor 2017.
377937C-01	May 2018	This version includes support for the NI 9351, the Functional Safety Editor 2018, and known issues resources for module firmware.

Table 1. C Series Functional Safety Manual Release Versions

## C Series Functional Safety Systems



## Related concepts

- [Finding Resources](#)

## Develop

### Offline Development Tools

- LabVIEW—provides a platform for deploying and monitoring User Programs.
- Functional Safety Editor—provides a platform to facilitate the creation of safety User Programs.

### What to Do

- Create a User Program in the Functional Safety Editor that implements the safety logic required by your safety instrumented function (SIF).
- Create a project in LabVIEW to download User Programs to the C Series Functional Safety module.
- (Optional) Develop a VI in LabVIEW to monitor module and channel status and to set outputs through digital passthrough.

## Deploy

### Offline, Non-Safety Support Tools

- CompactRIO controller—provides a hardware connection for deploying Safety Programs.
- LabVIEW—provides a software platform for deploying User Programs.

### Functional Safety System Components

- C Series Functional Safety module—contains a logic solver that runs User Programs and provides I/O that connects to inputs, final elements, and a power supply.
- User Program—contains a set of user-defined logic and actions that run in the logic solver. The User Program defines the system's responses to inputs and detected faults.
- Cabling, sensors, final elements (actuators)—allows the C Series Functional Safety module to connect, monitor, and control safety critical systems.

- External LPS power supply—powers the C Series Functional Safety module.

### What to Do

- Install and connect hardware components, including the CompactRIO controller, the C Series Functional Safety module, power supply, cabling, sensors, and final elements (actuators)
- Use the LabVIEW project to download the User Program to the logic solver on the C Series Functional Safety module while the module is not executing safety functionality.
- Validate the system by verifying system response to faults and system safety response time.

### Runtime

#### Online, Non-Safety Support Tools

- CompactRIO controller—provides a hardware connection for monitoring Safety Programs and setting outputs through digital passthrough.
- LabVIEW—provides a platform for monitoring User Programs.

#### Functional Safety System Components

- C Series Functional Safety module—contains a logic solver that runs User Programs and provides I/O that connects to inputs, final elements, and a power supply.
- User Program—contains a set of user-defined logic and actions that run in the logic solver. The User Program defines the system's responses to inputs and detected faults.
- Cabling, sensors, final elements (actuators)—allows the C Series Functional Safety module to connect, monitor, and control safety critical systems.
- External LPS power supply—powers the C Series Functional Safety module.

### What to Do

- Operate the safety User Program on the logic solver as part of your safety instrumented function (SIF).
- (Optional) Monitor the Functional Safety system through LabVIEW.

## Functional Safety Overview

Safety design, process, and validation conducted for the C Series Functional Safety modules followed the standards outlined in IEC 61508:2010.

C Series Functional Safety modules are certified SIL3 capable Type B devices for use in continuous demand applications in simplex deployment configurations. The certification only applies to the C Series Functional Safety module. The CompactRIO chassis and LabVIEW are not safety-certified.

To view the IEC 61508 certificate with failure rates and assessment report from exida, go to [ni.com/info](http://ni.com/info) and enter Info Code safetycert.

## FMEDA Assumptions

The FMEDA results assume the C Series Functional Safety modules are used as logic solvers in De-Energize to Trip safety functions. All external circuits connected to the C Series Functional Safety module must apply the De-Energize to Trip principle.



**Caution** The De-Energize to Trip principle must be applied both to safety inputs and outputs.

## Minimum Required Competency

All persons involved with planning, installing, connecting, or configuring software and hardware for use in safety systems that employ C Series Functional Safety modules must meet the following minimum competency requirements:

- Be informed about dependencies, risks, and consequences associated with safe operation, failure, and unsafe system conditions of any system employing C Series Functional Safety Modules.
- Have appropriate training and knowledge in the operation and implementation of industrial processes, measurement and control, automation, electrical engineering, and safety compliance.
- Have sufficient knowledge of all applicable codes, laws, regulations, and standards, including IEC 61508:2010.
- Be familiar with and have access to all requirements, conditions, specifications, and guidelines in all applicable NI documentation including

hardware documentation for the C Series Functional Safety module and CompactRIO chassis and the C Series Functional Safety manual.

## User Responsibilities

When deploying the safety system, users must:

- Create and configure the system HMI
- Define the system response for diagnostics in the User Program
- Be aware of and account for all documented known issues
- Validate and test the safety system prior to deployment
- Verify the safety response time of the system
- Document the validation test plan and results to demonstrate 100% test coverage.
- Change the module's mode to Operational Mode

When operating the safety system, users must:

- Monitor the HMI and/or module LEDs
- Conduct periodic proof tests as required by the application
- Respond to faults and detected unsafe conditions according to the safety plan
- Call National Instruments if the Internal Fault LED flashes more than three times then pauses.

## Hardware Requirements

- Follow all documented installation instructions, connection guidelines, and operating requirements for C Series Functional Safety modules and CompactRIO controllers employed in the safety system.
- Apply the De-Energize to Trip principle to all external circuits connected to the C Series Functional Safety module.

▪  
You must use a limited power source (LPS) supply suitable to the safety needs and configuration of the implemented system. Implement one of the following options to ensure continued compliance with IEC 61010-1.



- The Vsup must be powered from a Class 2 or Limited Power Source (LPS), SELV source, 30 V DC maximum.
- The Vsup must be powered from a SELV source, 30 V DC maximum, with supplementary overcurrent protection in series, 8 A maximum breaking capacity at 120 s.
- The C Series Functional Safety module and associated controller must be installed in an end-use fire enclosure.

## Software Requirements

- Install application software and device drivers appropriate to your hardware configuration. Refer to the following table for software applications and device drivers that are compatible with C Series Functional Safety modules.

NI 9350	NI 9351
Functional Safety Editor 2017 or later	Functional Safety Editor 2018 or later
LabVIEW 2017 or later	LabVIEW 2017 SP1 or later
LabVIEW Real-Time Module 2017 or later	LabVIEW Real-Time Module 2017 SP1 or later
CompactRIO Device Drivers 17.0 or later	CompactRIO Device Drivers 17.6 or later

Table 2. C Series Functional Safety Software Compatibility

- You must download a compiled User Program to the C Series Functional Safety module. You can create a User Program using the NI Functional Safety Editor. To download the necessary software, go to [ni.com/info](http://ni.com/info) and enter Info Code safetydownload.
- You must have a computer running 64-bit Windows 7, Windows 8.1, or later to install and use the Functional Safety Editor. The application is not compatible with 32-bit Windows versions.
- The LabVIEW Real-Time Module is only available in 32-bit. If you are using the LabVIEW Real-Time Module, you must download 32-bit application software and device drivers to a computer running a 64-bit operating system.
- You must verify and formally document that your safety application is not affected by any documented known issue. For a complete list of resources for determining the known issues for your software and firmware, refer to the **Finding Resources** section of this manual.



**Note** For minimum software support information, visit [ni.com/info](https://ni.com/info) and enter the Info Code swsupport.

### Related concepts

- [Functional Safety Editor](#)

### Security Requirements

Implement the following measures to protect against manipulation or corruption of the safety system.

- Determine and implement levels of access for hardware and software elements of the safety system.
- Transfer data only over secure connections.
- Limit personnel access to the C Series Functional Safety modules and the CompactRIO controller.
- Use locked enclosures to house the C Series Functional Safety modules and the CompactRIO controller.
- Implement operator authentication protections for software and network connections.
- Apply network segmentation strategies, such as firewalls or VPN.



**Note** For detailed information about security best practices for CompactRIO systems, visit [ni.com/info](https://ni.com/info) and enter the Info Code safetysecurity.

### Proof Test

The C Series Functional Safety module does not require a proof test. You do not need to include the module in a proof test plan for low-demand applications.

### Non-Safety Functionality

RIO Scan Interface downloads to the CompactRIO controller FPGA when you configure your system in the NI Measurement & Automation Explorer (MAX). Scan

Interface manages non-safety communication between the C Series Functional Safety module and LabVIEW Real-Time.

Scan Interface allows you to do the following:

- Read the values of inputs, outputs, and variables
- Read the status of fault diagnostics
- Monitor and set the module's Operating Mode
- Set output values with the digital passthrough

Related concepts

- [Module Operating Modes](#)
- [Passthrough](#)

Related tasks

- [Installing Hardware](#)

## Installing Hardware

1. Follow the instructions and guidelines in the getting started guides, datasheets, user manuals, and other hardware documentation for CompactRIO controllers and the C Series Functional Safety modules on [ni.com/manuals](http://ni.com/manuals).
2. Install the CompactRIO controller and C Series Functional Safety module(s).
3. Configure the system in the Measurement & Automation Explorer (MAX).
4. Connect the C Series Functional Safety module(s) to sensors, devices, and final elements as dictated by system requirements.
5. Connect the C Series Functional Safety module(s) to an external power supply.

## Installing Software

1. Refer to the LabVIEW Installation Guide on [ni.com/manuals](http://ni.com/manuals) to install LabVIEW and the NI-RIO device drivers.



**Note** Select NI 935x Functional Safety Module Support from the **LabVIEW Real-Time Software Wizard** when installing drivers on the controller.

2. Go to [ni.com/info](http://ni.com/info) and enter Info Code safetydownload.
3. Download and install the Functional Safety Editor.

## Running the Safety Editor

1. Launch the Functional Safety Editor.
2. Select File » New » Safety State Machine.



**Note** To begin with an example state machine, navigate to Help » Open examples... and double-click the example of your choice.

## Creating User Programs

1. The State Machine editor opens to the I/O Configuration table.
2. Select the Module and Diagram tab in the configuration pane.
  1. Specify the NI Safety Module.
  2. Update the Document name and the State Machine name.
3. Define properties for all inputs and outputs wired to the module based on the system configuration.
4. Press <Ctrl-E> to open the Diagram.
5. Add states and connect transitions as required by the safety plan.



**Note** To add additional state machines to a User Program, click the pull-down menu at the top of the state machine tab and select Add New State Machine.

## Compiling User Programs

Follow these steps to compile documents and output User Programs in the Functional Safety Editor.

1. Verify that there are no alerts in the Errors and Warnings pane.
2. Press <Ctrl-S> to save the state machine.
3. Click the Compile button.
4. Verify the User Program has compiled correctly.  
If the compile fails, do the following:
  1. Review the Errors and Warnings pane for compile errors.
  2. Address all errors and warnings.
  3. Repeat steps 1 through 4.
5. Verify that all inputs, outputs, and variables configured in the I/O Configuration table are used in the state machine diagram.
6. Verify that all diagnostics listed in the Faults table have Module failsafe selected or are used in the state machine diagram.



Note You can review the following files to verify your User Program:

- **<filename>.json**
- **<filename>\_errors.json**
- **<filename>\_report.log**

### Related concepts

- [Saving and Compiling](#)

## Creating a Functional Safety Project in LabVIEW

1. Launch LabVIEW.

2. Click the Create Project button to display the Project Explorer window. You can also select File » New Project to display the Project Explorer window.
3. Double-click Blank Project.
4. Right-click the top-level project item in the Project Explorer window and select New » Targets and Devices from the shortcut menu to display the Add Targets and Devices dialog box.
5. Ensure that the Existing target or device radio button is selected.
6. Expand Real-Time CompactRIO.
7. Select the CompactRIO controller to add to the project and click OK.
8. Click Continue. LabVIEW adds the controller and all the modules to the project.
9. Click Discover in the Discover C Series Modules? dialog box if it appears.
10. Select File » Save Project and save the project.

## Creating a Functional Safety Monitoring VI in LabVIEW

1. Right-click the Real-Time CompactRIO target item in the Project Explorer window.
2. Select New » VI from the shortcut menu to open a new VI front panel and block diagram.
3. Add channels or variables to block diagram to monitor inputs and outputs.
  1. Select the channel or variable nested under the module item in the Project Explorer window.

Available channels and variables include:

    - Analog input (NI 9351 only)
    - Digital input
    - Digital output
    - State machine variables
    - User-configurable LED
  2. Drag and drop the channel or variable onto the block diagram.

4. Add the Invoke Node to the block diagram to monitor the module status, diagnostics, set the module mode, or manually start the User Program.
5. Add the Property Node to the block diagram to monitor the firmware version, User Program GUID, User Program version, or other information about the C Series Functional Safety module.



**Note** For detailed information about using method and variables with C Series Functional Safety modules, open the LabVIEW Help and navigate to **NI CompactRIO Device Drivers » Devices » Functional Safety Modules**.

## Starting a User Program from LabVIEW

You can use an Invoke Node in LabVIEW to start the User Program on your C Series Functional Safety module. You must start the User Program from LabVIEW in the following situations:

- You disable auto start in the User Program by deselecting the box on the Module and Diagram tab of the Functional Safety Editor.
- User-configurable faults in the User Program trigger Fail-safe Mode.

## What to Do

1. Drag the C Series Functional Safety module (NI 935x) from the LabVIEW project and drop it onto the block diagram to create a reference constant.
2. Right-click the reference constant and select **Create » Method for 935x Class » Start Program** to place the Invoke Node.
3. Wire the reference constant to the reference terminal on the Invoke Node.

## Downloading User Programs

Follow these steps to download your User Program to the C Series Functional Safety module.



**Note** This procedure assumes you are interacting with the chassis in Scan Interface mode only. If your chassis is running in hybrid mode, stop any LabVIEW program running on the RT target in your LabVIEW project, set the chassis to Scan Interface mode, and deploy the chassis before downloading your User Program.

1. Open the LabVIEW project (.lvproj) created to monitor the safety system.
2. Right-click the module in the LabVIEW project and select Properties.
3. Click the Read Module button in the Current User Program section.
4. Verify current Build Number and Program GUID.  
If no User Program has been downloaded to the module, the fields will display as follows:
  - Build Number: 0
  - Program GUID: {00000000-0000-0000-000000000000}
  - Mode: Unprogrammed
5. Click the folder icon next to the Path to New User Program field in the New User Program section.
6. Locate and double-click the User Program (.bin).
7. Click the Download Program button to deploy the selected User Program to the C Series Functional Safety module.  
The Download Program window will open.
8. Type yes and click OK.  
The Download Message field will indicate successful completion or error. In the case of an error, click the Details button for more information.
9. Verify the Build Number and Program GUID fields have updated to match the build number and program GUID of the new User Program.  
In the Functional Safety Editor, the build number and program GUID are displayed on the Module and Diagram tab of the configuration pane.
10. Verify the module mode has updated to Verification Mode in the Mode field.
11. Click OK.



## Related concepts

- [Saving and Compiling](#)

## Verifying User Programs

Complete the following steps to change the mode to Operational Mode.



**Note** Verify that the User Program responds as expected for all configured faults.



**Note** Verify the safety response time for all configured faults.

1. Open the LabVIEW Project (.lvproj) created to monitor the safety system.
2. Right-click the module in the LabVIEW Project and select Properties.
3. Click the Change Mode to button.
4. Type verify and click OK.
5. Verify the module mode has updated to Operational Mode in the Mode field.

## Validating a Functional Safety System

1. Perform necessary system tests before implementation as required by safety plan.



**Note** System testing must provide 100% coverage for all transition statements and signal values in the User Program.

2. Create formal documentation to record system test plan and test results and to demonstrate 100% coverage.

## Module Independence

The C Series Functional Safety module is independent of the CompactRIO controller. The module must be powered by an external power supply. Loss of

controller power or communication with the controller does not affect the safety functionality of the module.

## Module Logic Solver (FPGA-based)

The primary safety function of the C Series Functional Safety module is to read inputs and set outputs based on safety logic defined in the User Program. A logic solver runs the User Program on an FPGA in the C Series Functional Safety module.



**Note** Any instance of the term **FPGA** in this manual refers to the FPGA internal to the C Series Functional Safety module that runs the module firmware, the logic solver, and the User Program, unless the instance explicitly indicates the controller FPGA.

## Module Operating Modes

- The module runs in Unprogrammed Mode when you first install and power on the module.
- While the User Program is downloading, the module runs in User Program Download mode.
- After a successful download, the module changes to Verification Mode.



**Note** In Verification Mode, the User Program is running normally.

- Perform validation procedures on your system while in Verification Mode.
- Change the mode to Operational Mode from your project in LabVIEW once validation of the system is complete.

The module will run in Operational Mode until one of the following things happen:

- You change the mode back to Verification Mode in LabVIEW.
- You cycle external power to the module.
- User-configured diagnostics or automatic self-diagnostics trigger Fail-safe Mode.



**Note** The module FPGA stops the User Program when the module changes from Verification Mode to Operational Mode or from Operational Mode to Verification Mode. If you enable auto start, the User Program will restart after the module changes modes. If you do not enable auto start, you will need to restart the User Program from LabVIEW.



**Note** Latched faults persist when the module changes operating mode. For more information on fault latching, refer to the **Fault Latching** section.

The RIO Scan Interface monitors and returns the module operating mode. You can view or change the operating mode in the Properties window in the LabVIEW project or with the Invoke Node in your LabVIEW VI.

Mode	What Is Happening	What to Do Next
Unprogrammed Mode	<ul style="list-style-type: none"> <li>▪ Hardware state out of the box</li> <li>▪ User Program is not written to the module</li> <li>▪ Vsup/Status LED flashes</li> </ul>	<ul style="list-style-type: none"> <li>▪ Develop the User Program in the Functional Safety Editor</li> <li>▪ Download the User Program to the module</li> </ul>
User Program Download Mode	<ul style="list-style-type: none"> <li>▪ User Program is downloading to the module</li> <li>▪ Vsup/Status LED flashes</li> </ul>	<ul style="list-style-type: none"> <li>▪ Verify the mode updates to Verification Mode</li> <li>▪ Verify the Build Number and the Program GUID update</li> </ul>
Verification Mode	<ul style="list-style-type: none"> <li>▪ User Program has downloaded to module and is running normally</li> <li>▪ User Program requires verification</li> <li>▪ Vsup/Status LED flashes</li> </ul>	<ul style="list-style-type: none"> <li>▪ Use this mode to perform necessary verifications based on system design</li> <li>▪ Monitor system for detected faults</li> <li>▪ Set module to Operational Mode</li> </ul>
Operational Mode	<ul style="list-style-type: none"> <li>▪ User Program is running on the module</li> </ul>	<ul style="list-style-type: none"> <li>▪ Perform maintenance and proof tests as determined by your safety plan</li> </ul>

Mode	What Is Happening	What to Do Next
	<ul style="list-style-type: none"> <li>Vsup/Status LED is on</li> </ul>	<ul style="list-style-type: none"> <li>Monitor system for detected faults</li> </ul>
Fail-safe Mode	<ul style="list-style-type: none"> <li>All outputs are de-energized</li> <li>User Program stops running</li> <li>Vsup/Status LED flashes</li> <li>Internal Fault LED flashes</li> <li>LabVIEW returns fault status information</li> </ul>	<ul style="list-style-type: none"> <li>Respond to fault as determined by user safety plan</li> <li>Cycle external <math>V_{SUP}</math> to the module</li> <li>Restart the User Program</li> <li>Return the module to Operational Mode as defined by your safety plan</li> </ul>

Table 3. Module Operating Modes

### Related tasks

- [Starting a User Program from LabVIEW](#)

### Fail-Safe Mode

Fail-safe Mode de-energizes all outputs from the C Series Functional Safety module and stops the User Program. You can still read diagnostics, inputs, and the module status in Scan Interface, but the User Program is no longer running. However, depending on the condition that triggered Fail-safe Mode, the data returned by Scan Interface may not be correct.

You can configure the User Program to trigger Fail-safe Mode in response to faults in the I/O Configuration table in the Functional Safety Editor. If a user-configurable fault triggers Fail-safe Mode, you must cycle external  $V_{SUP}$  power to the module and restart the User Program using the Invoke Node in the monitoring VI in LabVIEW. Automatic self-diagnostics will trigger Fail-safe Mode independently of User Program. If an automatic self-diagnostic triggers Fail-safe Mode, identify the condition causing the fault and remove it. For more information on automatic self-diagnostics, refer to the Automatic Self-Diagnostics section. Then, to exit Fail-safe Mode, cycle external  $V_{SUP}$  power to the module. The User Program will start automatically if auto start is enabled. Otherwise, restart the User Program using the Invoke Node in the monitoring VI in LabVIEW.

### Related concepts

- [Setting Faults to Trigger Fail-Safe Mode](#)

#### Related tasks

- [Starting a User Program from LabVIEW](#)

## Power Down Mode

In Power Down Mode, the C Series Functional Safety powers off and ceases all operation. The User Program stops running, all outputs de-energize, and the module no longer communicates with LabVIEW.

Automatic self-diagnostics can trigger Power Down Mode in the following situations:

- Short condition on both DO FETs on a single output channel
- Overvoltage on  $V_{\text{SUP}}$
- Internal overvoltage faults

If the module goes into Power Down Mode, follow these steps:

1. Inspect all inputs and outputs to verify they are within specifications.
2. Cycle external  $V_{\text{SUP}}$  to the module.
3. Contact NI if the module goes into Power Down Mode a second time.

## Functional Safety Editor

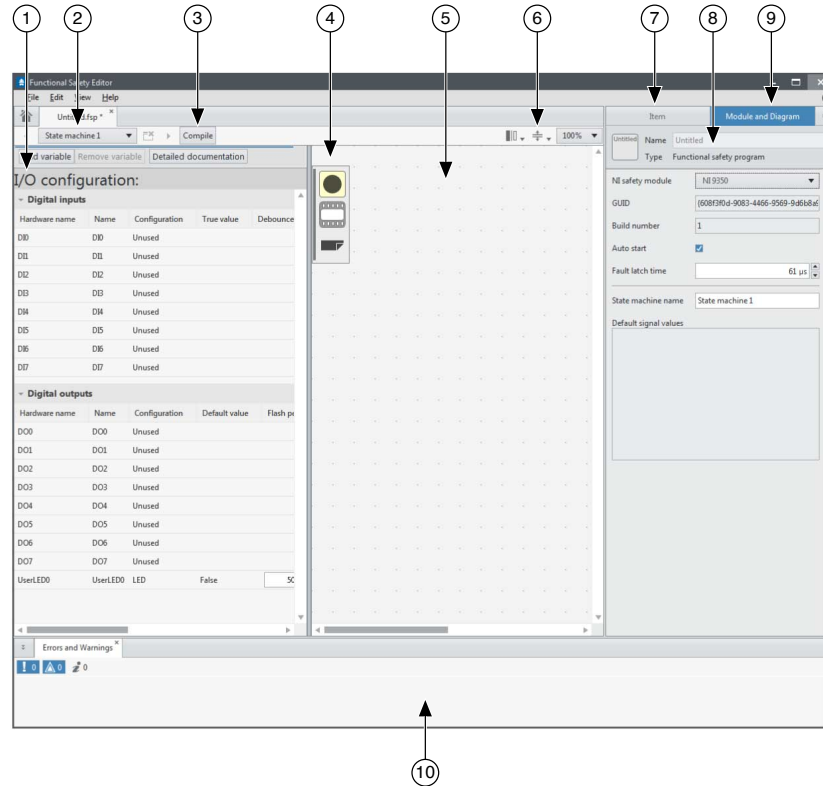
The Functional Safety Editor provides an interface to create and compile User Programs that implement the safety logic for your application. The compiled User Program deploys and runs on the module logic solver. Each User Program supports multiple state machines that run in parallel. Create up to eight state machines for the NI 9350 and create up to four state machines for the NI 9351.

The Functional Safety Editor allows users to do the following:

- Add states from the palette and define output behavior for those states
- Connect states with transitions and define input triggers for those transitions
- Configure input and output channels and variables in the I/O Configuration table

- Set default output values and variables for state machines and compound states

Figure 1. Functional Safety Editor



Use the following elements to navigate and configure the Functional Safety Editor.

1. I/O Configuration table—Use this table to configure the parameters for all inputs, outputs, variables, and faults used in your User Program.
2. State machine menu—Use this pull-down menu to switch between state machines or add state machines to the User Program.
3. Compile button—Click this button to compile your User Program. The compiler will generate a binary file you can download to your C Series Functional Safety module.
4. Palette—Use the palette to drag and drop simple states, compound states, and comments.
5. State machine diagram—Use this diagram to build your state machine. Add states from the palette and connect them with transitions.

6. **Switch view button**—Click this button to switch between the state machine diagram, the I/O Configuration table, or a split view. You can also switch between the I/O Configuration table and the state machine diagram by pressing <Ctrl-E>.
7. **Item tab**—Select this tab to update properties or access help documentation for the currently selected item in the state machine diagram.
8. **Configuration pane**—Use this pane to view the Item tab or the Module and Diagram tab.
9. **Module and Diagram tab**—Select this tab to update properties for the module and the User Program.
10. **Errors and Warnings pane**—Refer to this pane for possible issues with syntax or design of the User Program.

## Module and Diagram Tab

The **Module and Diagram** tab allows you to configure settings for the C Series Functional Safety module and for the User Program.

Figure 2. Module and Diagram Tab

1. Name—Displays the filename of the .fsp
2. NI safety module—Selects the C Series Functional Safety module that will run the User Program
3. GUID—Displays the unique ID of the User Program
4. Build Number—Displays the build number of the User Program
5. Auto start—Disables or enables the auto start function for the User Program
6. Fault Latch Time—Sets the fault latch time for the User Program
7. State machine name—Sets the name for the current state machine in the User Program
8. Default signal values—Displays the default signal values set on the I/O Configuration table

## Build Number

- Build number allows you to track versions of your User Program.



- When you create a new User Program, the initial build number on the Module and Diagram tab is 1.
- The binary file includes the current build number when it compiles.
- You can verify the build number sent to the compiler by checking the JSON.
- The build number on the Module and Diagram tab increments when you first edit a User Program that has successfully compiled.
- When you download a binary file to the module, you can confirm the build number and GUID of the binary file in the Properties dialogue in the LabVIEW project.

## Auto Start

- The auto start function starts the User Program under the following conditions:
  - When you cycle external power to the module
  - After successful download of a User Program
  - On power up
  - When you change operating modes
- Auto start is enabled by default. You can disable or enable auto start with the Auto start checkbox on Module and Diagram tab.
- If auto start is enabled, the User Program starts when the module changes to Verification Mode after a successful download.
- If auto start is disabled, users must restart the User Program from the Start Program Method in LabVIEW.
- Auto start disables when the User Program triggers Fail-safe Mode.



**Tip** When the User Program triggers Fail-safe Mode, auto start disables, preventing Fail-safe Mode loops and allowing you to download a new User Program.

- Cycling external power twice after the module goes into Fail-safe Mode re-enables auto start.

- Auto start does not disable when automatic self-diagnostics trigger Fail-safe Mode.

#### Related tasks

- [Starting a User Program from LabVIEW](#)

#### I/O Configuration Table

The I/O Configuration table allows you to configure parameters for all inputs, outputs, variables, and faults on the C Series Functional Safety module.

Figure 3. I/O Configuration Table

The screenshot shows the I/O configuration interface for the NI-9351. It includes several sections: Digital inputs, Digital outputs, Analog inputs, Variables, and Faults. Each section contains a table of hardware configurations. Callouts 1 through 7 identify key features: 1 points to the Faults table, 2 to the Variables table, 3 to the Analog inputs table, 4 to the Digital outputs table, 5 to the Digital inputs table, 6 to the 'Add variable' button, and 7 to the 'Detailed documentation' button.

Hardware name	Name	Configuration	True value	Debounce filter	Output line load
DIO	DIO	Dual input with test pulse	Active high	20000 $\mu$ s	Medium
DI1	DI1	Reserved by DIO			
DI2	DI2	Unused			
DI3	DI3	Unused			

Hardware name	Name	Configuration	Default value	Flash period (ms)	Output line load
DO0	DO0	Reserved by DIO			
DO1	DO1	Reserved by DIO			
DO2	DO2	Unused			
DO3	DO3	Unused			
User.LED0	User.LED0	LED	False	500 ms	

Hardware name	Name	Configuration	Low low threshold	Low threshold	High threshold
AI0	AI0	Unused			
AI1	AI1	Unused			
AI2	AI2	Unused			
AI3	AI3	Unused			

Hardware name	Name	Default value
Var0	Var0	False
Var1	Var1	False
Var2	Var2	False

Name	Module failsafe	Overcurrent recovery	Recovery time
DIO.DiscrepancyFault	<input type="checkbox"/>		
DIO.OvercurrentFault		No recover	
DIO.TestPulseFault	<input type="checkbox"/>		

1. Faults table
2. Variables table
3. Analog inputs table
4. Digital outputs table
5. Digital inputs table
6. Add variable button
7. Detailed documentation button

A new functional safety program opens to the I/O Configuration table for the NI 9350, showing only the digital output and digital input tables.

- To create a functional safety program for the NI 9351, select NI 9351 from the NI safety module pull-down menu on the Module and Diagram tab. This will add the analog input table to the I/O Configuration.
- To switch between the I/O Configuration table and the state machine diagram, press <Ctrl-E> or click the Switch View button at the top of the state machine tab.
- To add and populate the variable table, click the Add variable button at the top of I/O Configuration table. To remove a variable, select the variable in the variable table and click the Remove variable button.
- To add and populate the Faults table, start configuring inputs and outputs. The Faults table will populate based on the configurations selected.
- To view an online version of the C Series Functional Safety manual, click the Detailed documentation button.

## Related tasks

- [Configuring I/O Channels](#)

## Digital Configurations

Configuration	Channels		Notes
	NI 9350	NI 9351	
Single input	Available on any digital input channel.		—
Single input with test pulse	Available on any digital input channel.		Test pulse on DI <sub>n</sub> reserves DO <sub>n</sub> to generate the test pulse.
Dual input	Available on these channel pairs: [DI0, DI1], [DI2, DI3], [DI4, DI5], [DI6, DI7].	Available on these channel pairs: [DI0, DI1], [DI2, DI3].	A dual input on DI <sub>n</sub> , reserves DI <sub>n+1</sub> .
Dual input with test pulse	Available on these channel sets: [DI0, DI1, DO0, DO1], [DI2, DI3, DO2, DO3], [DI4, DI5, DO4, DO5], [DI6, DI7, DO6, DO7].	Available on these channel sets: [DI0, DI1, DO0, DO1], [DI2, DI3, DO2, DO3].	Test pulse on DI <sub>n</sub> reserves DI <sub>n+1</sub> , DO <sub>n</sub> and DO <sub>n+1</sub> .

Table 62. Digital Input Configurations

Configuration	Channels		Notes
	NI 9350	NI 9351	
Single output	Available on any digital output channel.		—
Single output with external readback	Available on any digital output channel.		Readback on external DOn reserves DI <sub>n</sub> .
Single output with internal test pulse	Available on any digital output channel.		—
Single output with external test pulse	Available on any digital output channel.		Outputs a test pulse on DOn and reserves DI <sub>n</sub> to monitor test pulse.
Dual output	Available on these channel pairs: [DO0, DO1], [DO2, DO3], [DO4, DO5], [DO6, DO7].	Available on these channel pairs: [DO0, DO1], [DO2, DO3].	Dual output on DOn reserves DOn+1.
Dual output with Internal test pulse	Available on these channel pairs: [DO0, DO1], [DO2, DO3], [DO4, DO5], [DO6, DO7].	Available on these channel pairs: [DO0, DO1], [DO2, DO3].	Dual outputs with test pulses on DOn and DOn+1.
Dual output with external test pulse	Available on these channel pairs: [DO0, DO1, DI0, DI1], [DO2, DO3, DI2, DI3], [DO4, DO5, DI4, DI5], [DO6, DO7, DI6, DI7].	Available on these channel pairs: [DO0, DO1, DI0, DI1], [DO2, DO3, DI2, DI3].	Dual outputs with test pulses on DOn and DOn+1 and reserves DI <sub>n</sub> and DI <sub>n</sub> +1 to monitor test pulses.

Table 5. Digital Output Configurations



**Note** Dual input and dual output configurations are only available on the even-numbered channel. Only the even-numbered channel will be available in the Faults table or on the state machine diagram.

#### Related concepts

- [User-Configurable Digital Diagnostics](#)

#### Related reference

- [Digital Input Configurations](#)

- [Digital Output Configurations](#)

## Analog Configurations (NI 9351 Only)

The NI 9351 has four analog input channels. You can use them to create the following configurations.

Configuration	Channels	Notes
Single input (1oo1)	Available on any analog input channel.	Monitors current ranges for a single analog signal.
Dual input (1oo2)	A dual input configuration available on the following channel pairs: [AI0, AI1] and [AI2, AI3].	Establishes a 1oo2 voting strategy on two analog input channels. Configuring AI0 reserves AI1 and configuring AI2 reserves AI3.
Triple input (2oo3)	A triple input configuration is only available on AI0.	Establishes a 2oo3 voting strategy on three analog input channels. Configuring AI0 reserves AI1 and AI2.

Table 6. Analog Configurations



**Note** Dual input (1oo2) configurations are only available on the even-numbered channel. Only the even-numbered channel will be available in the Faults table or on the state machine diagram.



**Note** A triple input (2oo3) configuration is only available on AI0. Only AI0 will be available in the Faults table or on the state machine diagram.

### Related concepts

- [User-Configurable Analog Diagnostics \(NI 9351 Only\)](#)

### Related reference

- [Analog Input Configurations \(NI 9351 Only\)](#)

### Variables

- Variables are Boolean values used to communicate between individual state machines in a User Program and with Scan Interface.
- The User Program supports up to 24 variables.

- You can create variables in the I/O Configuration table by clicking the Add variable button.
- You can remove variables by selecting the variable you want to delete and clicking the Delete variable button.
- Only one state machine can write to a given variable.
- You can use variables as both signal values and transition conditions.
- Variables are read-only in Scan Interface.

## Naming Channels and Variables in the I/O Configuration Table

Follow these guidelines when naming channels and variables in the I/O Configuration table:

- Rename the channel or variable by double-clicking the default name in the Name column.
- Use only Unicode 5.0 language-type characters.
- Do not use Boolean operators as names.
- Do not use spaces in channel or variable names. Replace spaces with underscores.
- Refer to the following table for a list of common keywords and operators that are not allowed for use in channel or variable names.



**Note** The Functional Safety Editor will not allow you to enter forbidden characters.

Keywords		Operators		
after	or		+	!
true	and	&&	*	.
false	not	^^	()	=

Table 15. Forbidden Keywords and Operators

## Digital I/O Parameters

When you select a configuration for a channel, the I/O Configuration table enables the appropriate parameters. Refer to the following table for the parameters associated with each configuration.

Signal Type	Configuration	Parameters
Digital Inputs	Single input	True value, Debounce filter
	Single input with test pulse	Test pulse period, Test pulse width, True value, Debounce filter, Output line load
	Dual input	True value, Discrepancy time, Debounce filter, Complementary
	Dual input with test pulse	Test pulse period, Test pulse width, True value, Discrepancy time, Debounce filter, Complementary, Output line load
Digital Outputs	Single output	Default value, Output line load, Flash period
	Single output with external readback	Default value, Readback delay, Output line load, Flash period, Debounce filter
	Single output with internal test pulse	Default value, Test pulse period, Test pulse width, Output line load, Flash period
	Single output with external test pulse	Default value, Test pulse period, Test pulse width, Output line load, Flash period, Debounce filter
	Dual output	Default value, Output line load, Flash period
	Dual output with Internal test pulse	Default value, Test pulse period, Test pulse width, Output line load, Flash period
	Dual output with external test pulse	Default value, Test pulse period, Test pulse width, Output line load, Flash period, Debounce filter
UserLED0	LED	Default value, Flash period

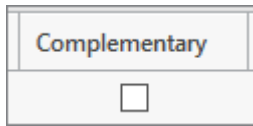
Table 13. I/O Configuration Parameters

### Complementary

The complementary parameter configures how the User Program evaluates dual inputs. Check the complementary box to configure the dual inputs as complementary. Leave the box unchecked to configure the dual inputs as equivalent. The complementary parameter is available on the even-numbered channel.



Figure 4. Complementary



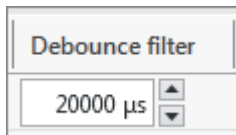
Related reference

- [Discrepancy Diagnostics for Digital Inputs](#)

Debounce Filters

You can set debounce filters on any digital input channel.

Figure 5. Debounce Filter



Debounce filters are timers that debounce mechanical switches or filter noise and transitions.

The filter timer begins at the rising or falling edge of the unfiltered input signal. The User Program reads the previous value of the signal for the duration of the filter time. After the filter time elapses and no new edges on the input signal have occurred, the User Program reads the new signal value. The filter timer restarts at the next edge of the of the unfiltered input signal.

Figure 6. Debounce Filter on an Active High Input

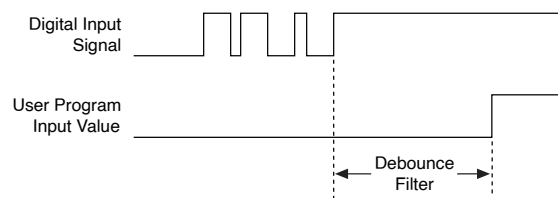
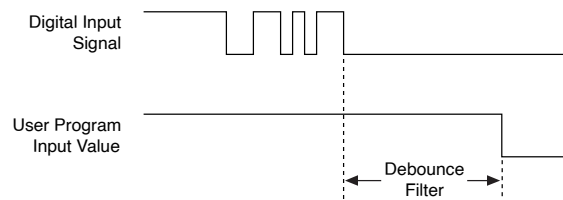


Figure 7. Debounce Filter on an Active Low Input



Refer to the following table to calculate maximum filter times. For information on calculating input signal response times, refer to the **Input Signal Response Time** section.

DI Configuration	Filtered Signal Time Maximum	Detected Signal Time Minimum
Single input and dual input	<b>Debounce filter time</b> - 15 $\mu$ s	Input signal response time (0 to 1)
Single input with test pulse and dual input with test pulse	<b>Debounce filter time</b> - ( $2 \times$ <b>test pulse width</b> ) - ( $2 \times$ <b>debounce constant</b> ) - 43 $\mu$ s	

Table 9. Calculating Debounce Filter Times



**Tip** To turn off filters, set filter value to 0.



**Note** To use debounce filters with test pulses, refer to the **Filter Times for Test Pulses** section for maximum and minimum debounce filter values.



**Note** A debounce filter on digital inputs clears when the User Program first starts. Digital inputs that are true when the User Program starts will read false until the debounce filter time elapses.

### Default Value

Default value is a required parameter that defines the default signal value for outputs, variables, and the UserLED0.

Figure 8. Default Value

Default value
False

### Related concepts

- [Default Signal Values](#)
- [Output Signal Value Syntax](#)

### Discrepancy Time (Digital Configurations)

Discrepancy time defines the delay before the User Program checks whether the signals are complementary or equivalent, based on your configuration.

Figure 9. Discrepancy Time

A screenshot of a control panel with a label 'Discrepancy time' above a numeric input field. The input field contains the value '1000 μs' and has up and down arrow buttons on its right side.

Dual input configurations introduce additional discrepancy due to signal routing and counter timebases. This results in a maximum tolerable discrepancy which is shorter than the configured parameter by the amount of an FPGA-based minimum discrepancy timer.

**Maximum tolerable discrepancy = discrepancy time - minimum discrepancy timer**

Refer to the following table to calculate the minimum discrepancy timer values based on the configuration.

Debounce Filter Time	Dual Input	Dual Input with Test Pulse
$0 \mu\text{s} < \text{debounce filter time} \leq 50 \mu\text{s}$	100 $\mu\text{s}$	—
$50 \mu\text{s} < \text{debounce filter time}$	$2 \times \text{debounce filter time}$	$(2 \times \text{debounce filter time}) + \text{test pulse width}$

Table 61. Calculating Minimum Discrepancy Timer Values



**Note** You cannot set **debounce filter time** < 108  $\mu\text{s}$  when using dual input with test pulse.

#### Related reference

- [Discrepancy Diagnostics for Digital Inputs](#)

#### Flash Period

You can set the flash period for any output.

Figure 10. Flash Period

A screenshot of a control panel with a label 'Flash period (ms)' above a numeric input field. The input field contains the value '500 ms' and has up and down arrow buttons on its right side.

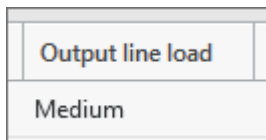
- The flash period is defined by the time the output is on plus the time the output is off. The output on/off time equals half of the flash period.

- Set the signal value to DOn = flash in the state machine diagram to use the flash period.
- Set the flash period large enough to allow the readback diagnostic to run: **Flash period** > 2 × **Readback response time**
- When using test pulses, set the flash period large enough to allow the test pulse to run: **Flash period** > 2 × **Test pulse period**

## Output Line Load

You can set the line load for digital outputs or digital inputs with test pulses.

Figure 11. Output Line Load



Setting an appropriate output line load is necessary for test pulse and readback diagnostics. Heavy output line loads work for all applications within module specifications but will result in slower response times. Reducing output line loads will enable shorter test pulses, readback delays, and faster response times.

There are two ways to set output line load:

- Calculate the discharge time using the following equation and the **Output Line Load for Input Discharge Times** table.
- Approximate the discharge time based on the configuration, external load, cable length and capacitance using the **Output Line Load Recommendations** table.

$$t = -R \times (C + 600 \text{ pF}) \times \ln\left(\frac{R \times 0.8 \text{ mA} + 5.7 \text{ V}}{R \times 0.8 \text{ mA} + 30 \text{ V}}\right)$$

Input Discharge Time	Output Line Load
<b>Discharge time</b> < 40 μs	Very Light
40 μs < <b>discharge time</b> < 1,000 μs	Light
1,000 μs < <b>discharge time</b> < 10,000 μs	Medium
10,000 μs < <b>discharge time</b> < 100 ms	Heavy

Table 11. Output Line Load Discharge Times

Configuration	External Load <sup>[1]</sup>	Cable Length/ Capacitance	Output Line Load
<ul style="list-style-type: none"> <li>▪ Single output</li> <li>▪ Dual output</li> <li>▪ Single output with internal test pulse</li> <li>▪ Dual output with internal test pulse</li> </ul>	High Impedance	≤10 m and ≤1.8 nF	Light
	High Impedance	≤50 m and ≤9 nF	Medium
	High Impedance	>50 m	Heavy
	≤3 kΩ	≤10 m and ≤1.8 nF	Very Light
	≤3 kΩ	≤50 m and ≤9 nF	Light
	≤3 kΩ	>50 m	Medium
	<ul style="list-style-type: none"> <li>▪ Single output with external test pulse</li> <li>▪ Dual output with external test pulse</li> <li>▪ Single output with external readback</li> <li>▪ Single input with test pulse</li> <li>▪ Dual input with test pulse</li> </ul>	>3 kΩ	≤50 m and ≤9 nF
>3 kΩ		>50 m	Medium
≤3 kΩ		≤50 m and ≤9 nF	Very Light
≤3 kΩ		>50 m	Medium

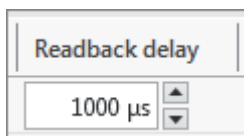
Table 33. Output Line Load Recommendations

<sup>1</sup> When the output load on the DO channel is a DI channel on the same module, load is >3 kΩ.

### Readback Delay

The readback delay parameter sets the maximum time for a signal to propagate from the configured output channel to the reserved input channel. Setting this value too low could result in a false readback fault.

Figure 12. Readback Delay



### Related concepts

- [Readback Diagnostics](#)

## Test Pulse Parameters

For channels configured with internal or external test pulses, you can configure the test pulse width and the test pulse period. For more information on configuring test pulses, refer to the **Test Pulses** section.

Figure 13. Test Pulse Parameters

Test pulse width	Test pulse period
15000 $\mu\text{s}$	60000 $\mu\text{s}$

### Related concepts

- [Test Pulses](#)

## True Value

You can define the true value for input channels. The User Program will read the input signal as true when the channel returns the value configured by the parameter.

Figure 14. True Value

True value
Active high

The options for true value are active high or active low.



**Note** Scan Interface reads the input signal, not the parameter in the User Program. If the input signal is high, Scan Interface will return a true value. If the input signal is low, Scan Interface will return a false value.

## Analog I/O Parameters (NI 9351 Only)

When you select a configuration for a channel, the I/O Configuration table enables the appropriate parameters. Refer to the following table for the parameters associated with each configuration.

Signal Type	Configuration	Parameters
Analog Inputs	Single input (1oo1)	Low low threshold, Low threshold, High threshold, High high threshold, Hysteresis

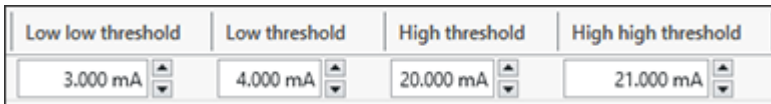
Signal Type	Configuration	Parameters
	Dual input (1oo2)	Low low threshold, Low threshold, High threshold, High high threshold, Hysteresis, Discrepancy time, Discrepancy current
	Triple input (2oo3)	Low low threshold, Low threshold, High threshold, High high threshold, Hysteresis, Discrepancy time, Discrepancy current

Table 13. I/O Configuration Parameters

### Thresholds

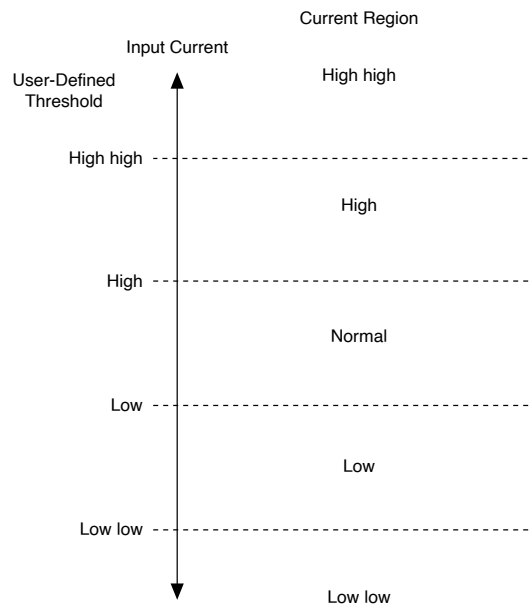
The Safety Editor allows you to set four current thresholds for each analog input configuration. The User Program applies the threshold values to every channel in the configuration.

Figure 15. Thresholds



Current thresholds define five regions that describe the state of the input. The module FPGA converts the current region for a channel into a Boolean value that can be read by the User Program. You can use the Boolean values for a current region as transition conditions in the state machine diagram.

Figure 16. Current Regions



Refer to the following guidelines when configuring thresholds:

- The four thresholds must be in a consecutive, increasing order. Low must have a larger value than low low, high must have a larger value than low, and high high must have a larger value than high.
- To ensure the module FPGA returns a low low region for a channel, set the low low threshold high enough to filter out inaccuracy and noise.
- The hysteresis ranges of two thresholds must not overlap. If you set the hysteresis range to 0.100 mA, the difference between any two thresholds must be >0.200 mA.
- If your system requires fewer than five configured current regions, you can conceal unnecessary regions, but the configured regions must be adjacent. For instance, you can configure low, normal, and high current regions, but not low, normal, and high high current regions.
- Set the high high and/or low low thresholds to their extreme values to conceal the outermost current regions.
- When concealing an outermost current region, use Boolean OR statements in transition conditions. For instance, if you don't want to use the high high current region, transitions that trigger on high should read AIn.H or AIn.HH.

#### Related concepts

- [Current Threshold Diagnostics](#)

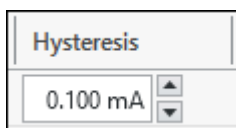
#### Related reference

- [Analog Input Configurations \(NI 9351 Only\)](#)

#### Hysteresis

You can set a hysteresis range that applies to all configured thresholds on an analog input configuration.

Figure 17. Hysteresis

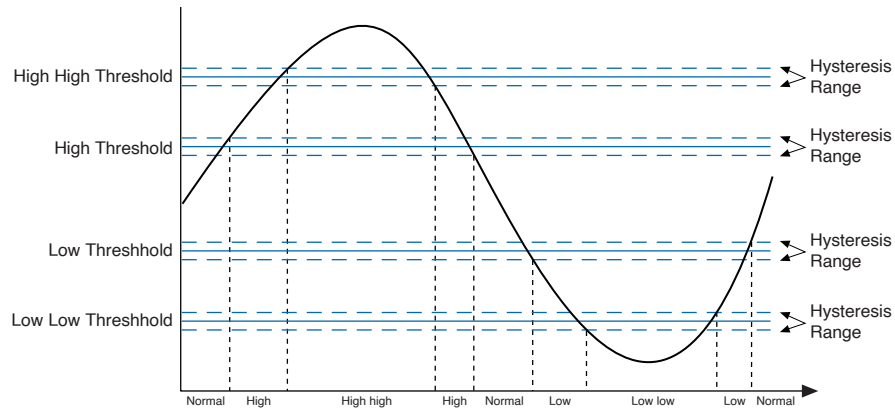


Refer to the following guidelines when setting a hysteresis value for your analog configurations:



- The hysteresis range affects both the rising edge and the falling edge of the incoming signal. A hysteresis value of 0.100 mA filters the incoming signal between +0.100 mA and -0.100 mA of each configured threshold value.

Figure 18. Hysteresis Range for Input Signals



- The User Program applies the hysteresis value to all four thresholds. The hysteresis range of one threshold can not overlap the hysteresis range of another threshold.
- In dual input and triple input configurations, the hysteresis and threshold values apply to every channel in that configuration.

#### Related concepts

- [Current Threshold Diagnostics](#)

#### Discrepancy Time (Analog Configurations)

Discrepancy time sets the minimum time duration that a discrepancy current can exist between channels before a discrepancy warning or discrepancy fault is detected.

Figure 19. Discrepancy Time



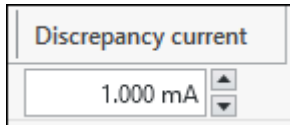
#### Related concepts

- [Discrepancy Faults for Analog Input Configurations](#)
- [Discrepancy Warning](#)

## Discrepancy Current

You can define a discrepancy value for input currents on dual input and triple input configurations. If the input channels read currents that differ by more than the defined parameter after the discrepancy time has expired, the module FPGA will return a Discrepancy Fault or a Discrepancy Warning to the User Program, based on your configuration.

Figure 20. Discrepancy Current



**Tip** To maximize the effectiveness of discrepancy current detection, set the discrepancy current parameter as low as the system will allow. In most systems, the discrepancy current should be significantly less than the normal current range (**high threshold - low threshold**).



**Note** You must set the discrepancy current greater than 0 mA.

### Related concepts

- [Discrepancy Faults for Analog Input Configurations](#)
- [Discrepancy Warning](#)

### Related reference

- [Analog Input Configurations \(NI 9351 Only\)](#)

## Setting Faults to Trigger Fail-Safe Mode

The Faults table populates based on the channel configurations you select.

Figure 21. Faults Table

▼ Faults			
Name	Module failsafe	Overcurrent recovery	Recovery time
DI0.DiscrepancyFault	<input type="checkbox"/>		
DI0.OvercurrentFault		Failsafe	
DI0.TestPulseFault	<input type="checkbox"/>		
AI0.OvercurrentFault	<input type="checkbox"/>		
AI0.DiscrepancyFault	<input type="checkbox"/>		
AI0.DiscrepancyWarning			
DO2.OvercurrentFault		Failsafe	
DO2.OpenCircuitFault	<input type="checkbox"/>		
DO2.TestPulseFault	<input type="checkbox"/>		

If you check the Module failsafe box next to a fault, that fault will trigger the module to go into Fail-safe Mode. Checking the box also reserves that signal so it cannot be used in the state machine diagram. If you leave the box unchecked, you can use that signal as an input to trigger transitions in the state machine diagram.

To set Module failsafe for overcurrent faults on digital input and digital output configurations, select Failsafe from pull-down menu in the Overcurrent recovery column.



**Caution** All fault signals listed in the Faults table must have the Module failsafe box checked or must be used as transition conditions in the state machine diagram. If a fault occurs and that fault signal is not configured, the fault will not be handled by the User Program.



**Tip** You can copy and paste the fault name to avoid retyping it in the state machine diagram. Click on the fault name and press <Ctrl-C> to copy the fault name in the I/O Configuration table. If you're using the Functional Safety Editor 2018 or later, output signal values and transition conditions have a predictive text feature that allows you to choose from a list of available faults.

#### Related concepts

- [Fail-Safe Mode](#)

- [Diagnostics](#)
- [Fault Response Time](#)

### Overcurrent Recovery (Digital Configurations)

When an overcurrent condition occurs on a digital channel, the channel de-energizes and the User Program returns an overcurrent fault. Configuring a digital input with test pulses or output populates the Faults table with an overcurrent fault for that channel.

Figure 22. Overcurrent Faults in the Faults Table

▼ Faults			
Name	Module failsafe	Overcurrent recovery	Recovery time
DO0.ReadbackFault	<input type="checkbox"/>		
DO0.OvercurrentFault		No recover	
DO0.OpenCircuitFault	<input type="checkbox"/>		
DI4.DiscrepancyFault	<input type="checkbox"/>		
DI4.OvercurrentFault		No recover	
DI4.TestPulseFault	<input type="checkbox"/>		

Overcurrent faults include an Overcurrent recovery pull-down menu that allows you to configure how the module responds when that channel reads an overcurrent condition.

- **Failsafe**—The module goes into Fail-safe Mode until you cycle external  $V_{SUP}$  power to the module. This selection functions in the same way as checking the module failsafe box for other fault signals.

Figure 23. Overcurrent Fault Set to Failsafe

▼ Faults			
Name	Module failsafe	Overcurrent recovery	Recovery time
DO0.OvercurrentFault		Failsafe	

- **Auto recover**—The channel de-energizes. After the Recovery time elapses, the fault will clear, allowing the user program to energize the output again. If the current remains in an overcurrent state, the channel will de-energize again. The de-energize and auto recover cycle will continue until the module no longer reads an overcurrent condition.

Figure 24. Overcurrent Fault Set to Autorecover

Faults			
Name	Module failsafe	Overcurrent recovery	Recovery time
DO0.OvercurrentFault		Auto recover	3 s

- **No recover**—The channel de-energizes and remains de-energized until you cycle external  $V_{SUP}$  power to the module. You can use the fault as a transition condition in the state machine diagram.

Figure 25. Overcurrent Fault Set to No Recover

Faults			
Name	Module failsafe	Overcurrent recovery	Recovery time
DO0.OvercurrentFault		No recover	

### Related concepts

- [Overcurrent Diagnostics \(Digital\)](#)

### Configuring I/O Channels

1. Open the I/O Configuration table.
2. Select the appropriate channel in the digital inputs, digital outputs, or analog inputs table.
3. Click the channel name in the Name column to rename the channel, if necessary.



**Note** You must use the channel name set in the I/O Configuration table when programming output values and transitions.

4. Click the cell in the Configuration column to select the configuration type for that channel.
5. Update the I/O parameters, as necessary.
6. Repeat steps 2 through 5 for all connected channels.
7. Verify that you have done the following:
  - Set a default value for all configured digital outputs.

- Selected Module failsafe for applicable fault diagnostics.
- Set a default value for all variables.

### Related concepts

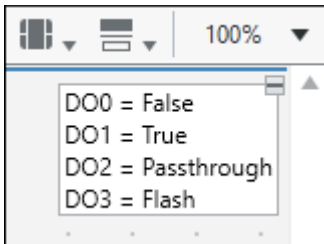
- [I/O Configuration Table](#)

### Default Signal Values

You must set the default signal value for every output and variable you configure in the I/O Configuration table. When you use an output or variable in a state machine the default value appears in the Default signal values field on the Module and Diagram tab of the configuration pane for that state machine. The default values will apply when the User Program commences execution. If output values are not defined by the current state, the default value for that output will apply.

Default signal values appear in a pane in the upper right-hand corner of the state machine diagram.

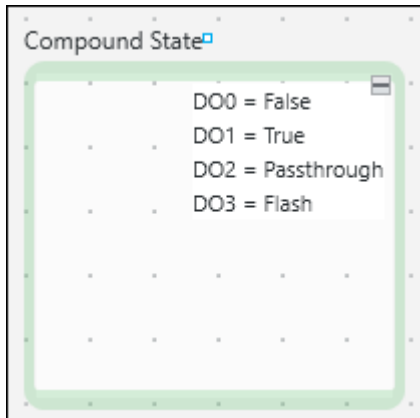
Figure 26. Default Signal Values in State Machine Diagram



You can define default signal values for compound states by editing the Signal values field on the Item tab of the configuration pane. These default values will apply when the User Program transitions into that compound state. If output values are not defined by the current simple state, the default value for that output will apply.

Default signal values for compound states appear in a pane in the upper right-hand corner of the compound state.

Figure 27. Signal Values for Compound States in the State Machine Diagram



**Tip** You can shrink or expand the default signal value pane by clicking the small square at the top of the pane.

#### Related concepts

- [Compound States](#)

#### Passthrough

Setting the digital output value to passthrough allows you to write directly to digital output channels through Scan Interface.

Use the following syntax to configure a digital output channel for passthrough: <channel name> = passthrough, where <channel name> is the name of the digital output channel defined in the I/O Configuration table.

When communication to the controller is lost, the output value of the passthrough channel will be set to False. Once communication is restored, Scan Interface will be able to write the output value to the passthrough channel.



**Note** Digital passthrough may behave differently depending on which version of the firmware you have installed. For more information about differences in firmware versions, refer to the **C Series Functional Safety Firmware Versions** section.



**Caution** The digital passthrough bypasses the User Program and should not be used for safety-critical outputs.

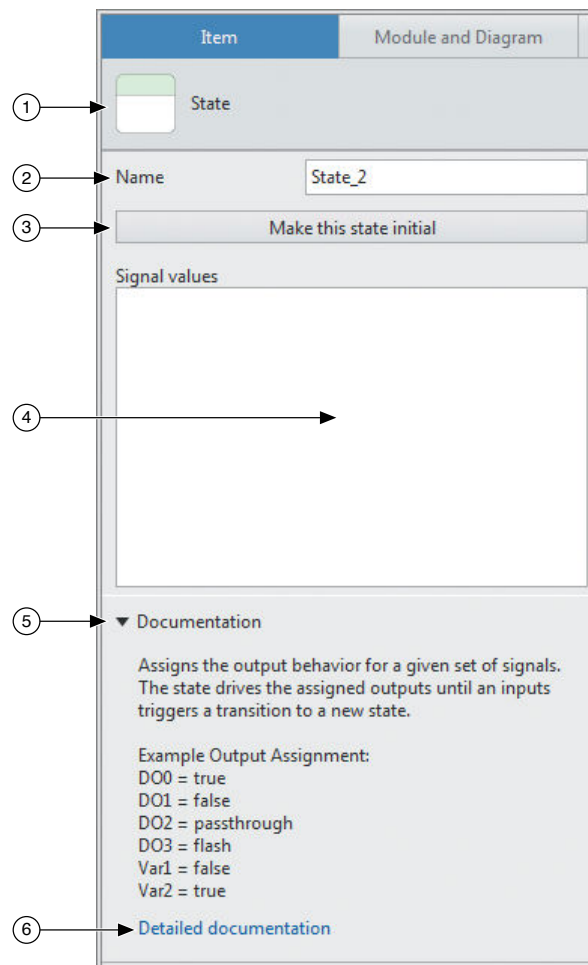


**Tip** Consider using passthrough during proof tests or when validating your system.

## States

States represent a set of driven outputs that run until specified inputs trigger a transition. A single state machine supports up to 32 states. Drag and drop states from the palette in the state machine diagram and modify states in the diagram or on the Item tab of the Configuration pane.

Figure 28. State Item Tab



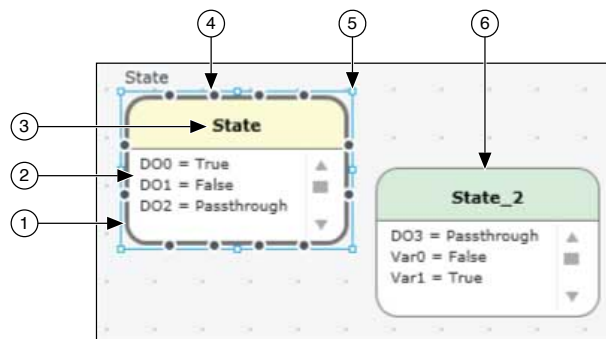


1. **State icon**—The icon and label indicate whether the state is simple or compound.
2. **State name**—This field allows you to rename the state.
3. **Make this state initial button**—This button allows you to set any intermediate state as the initial state for that state machine or compound state. Compound states can also be set as the initial state for a state machine.
4. **Signal states field**—This field contains the signal values for simple states or the default signal values for compound states.
5. **Documentation**—The documentation section provides helpful information about states.
6. **Detailed documentation link**—This link connects to the C Series Functional Safety Manual on [ni.com/manuals](http://ni.com/manuals).

## Simple States

Simple states drive a specified list of outputs that run in response to system inputs.

Figure 29. Simple State Elements



1. **Initial state**—An initial state sets the signal values for the User Program or compound state when execution commences. All other states are intermediate states. Initial states are yellow and have thick gray borders.
2. **State output field**—This field displays the output values for a given simple state. You can type the output values directly into the field.
3. **State name field**—This field displays the state name. You can rename the state by clicking directly on the field.
4. **Terminal**—Terminals allow you to connect transitions between states. Each simple state has twelve terminals.

5. **Resize handle**—Resize handles allow you to increase or decrease the size of the state.
6. **Intermediate state**—An intermediate state is any simple state that is not an initial state. Intermediate states are green with a thin gray border.



**Note** To change an intermediate state to an initial state, right-click the state and select **Make this state initial**. You can also select **Make this state initial** on the **Item** tab of the configuration pane.

### Related concepts

- [Output Signal Value Syntax](#)

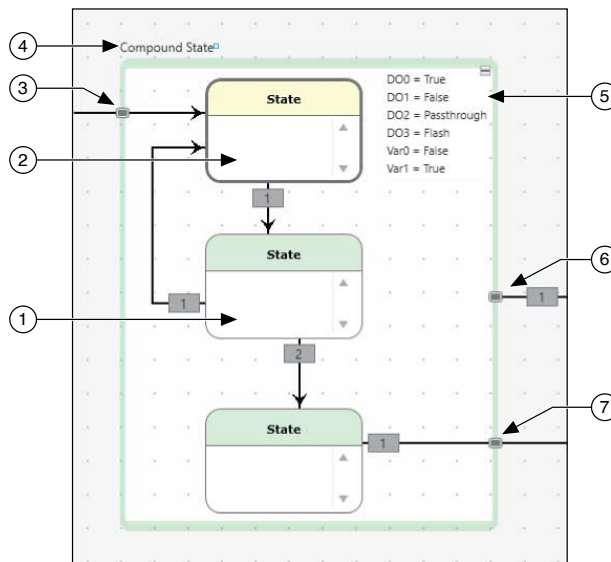
### Related tasks

- [Adding States](#)

### Compound States

Compound states are sub-state machines that contain simple states and transitions. Compound states can nest within other compound states.

Figure 30. Compound State Elements



1. **Intermediate state**—Intermediate states can serve as the destination for transitions from states inside or outside of the compound state.

2. **Initial state**—Transitions to terminals on the border of compound states will trigger the initial state.
3. **Terminal**—Terminals can connect external transitions to the border of the compound state. They can also act as tunnels to connect transitions with simple states inside the compound state. To create compound state terminals:
  - Double-click the edge of the compound state.
  - Connect a transition to the edge of a compound state.
  - Connect a transition to simple state within the compound state.
4. **Compound state name**—This field displays the name of the compound state. You can rename the compound state by clicking directly on the field.
5. **Default signal values**—This field displays the default signal values for the compound state. You can expand or collapse the field by clicking the box in the upper right corner.
6. **Transition from compound state**—Transition conditions can trigger transitions from the borders of compound state. If the statement evaluates as true, the User Program will transition out of the compound state regardless of the current simple state.
7. **Transition from simple state**—Transition conditions can trigger transitions from simple states within the compound state. If the statement evaluates as true, the User Program will transition out of the compound state.

#### Related concepts

- [Output Signal Value Syntax](#)
- [Default Signal Values](#)

#### Related tasks

- [Adding States](#)

#### Output Signal Value Syntax

States require Boolean statements to set output signal values. Statements include the channel or variable name and a keyword that defines the signal value.

Follow these guidelines when writing output signal values:

- You must use the channel name or variable name defined in the Name column of I/O Configuration table. Do not use the name defined in the Hardware name column.
- Keywords are not case-sensitive.
- Only one state machine can write to a given output channel or variable.
- The User Program resolves the innermost state for a given output or variable.

Type	Syntax	Keywords	Notes
Output channel	<channel name> = <keyword>	True	Energizes channel
		False	De-energizes channel
		Flash	Output toggles at user-configurable interval
		Passthrough	Allows monitoring VI in LabVIEW to set output value
Variable	<variable name> = <keyword>	True	Sets variable value to true
		False	Sets variable value to false
UserLED0	UserLED0 = <keyword>	True	Sets LED on
		False	Sets LED off
		Flash	Sets LED flashing behavior

Table 16. Output Signal Value Syntax

### Related concepts

- [Simple States](#)
- [Compound States](#)

### Related tasks

- [Adding States](#)

### Adding States

Follow these steps to add simple states to the state machine diagram.

1. Select the state on the palette.

2. Drag the state from the palette and drop it onto the state machine diagram.
3. Update the state name in the state name field on the state or in the Name field on the Item tab of the configuration pane.
4. Configure output signal values for the state using the text field on the state or in the Signal values field on the Item tab of the configuration pane.



**Note** You must use the channel name or variable name defined in the Name column of I/O Configuration table. Do not use the name defined in the Hardware name column.



**Tip** In the Functional Safety Editor 2018 or later, output signal values have a predictive text feature. You can start typing or push <Ctrl-Space> to display a menu of possible channel names or output signal values based on how you configured the I/O configuration table.

#### Related concepts

- [Simple States](#)
- [Compound States](#)
- [Output Signal Value Syntax](#)

#### Naming States in the State Machine Diagram

Follow these guidelines when naming states in the state machine diagram:

- Use only Unicode 5.0 language-type characters.
- Do not use Boolean operators as names.
- Do not use numbers.
- Do not start the state name with a space or an underscore.
- Refer to the following table for a list of common keywords and operators that are not allowed for use as state names.



**Note** The Functional Safety Editor will not allow you to enter forbidden characters.

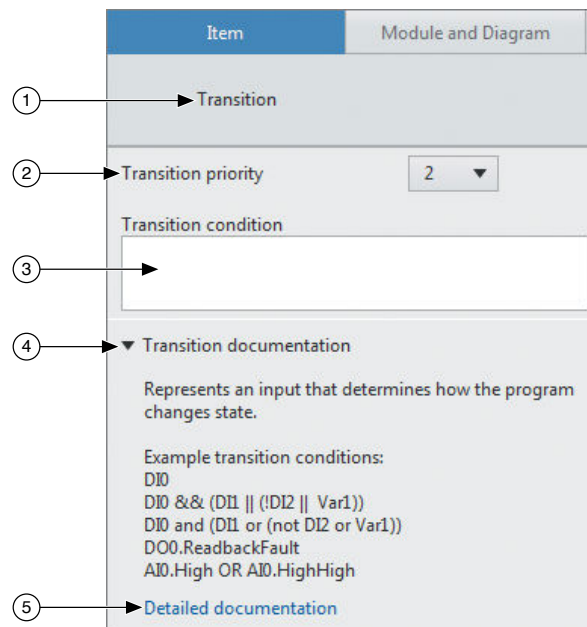
Keywords		Operators		
after	or		+	!
true	and	&&	*	.
false	not	^^	()	=

Table 15. Forbidden Keywords and Operators

## Transitions

Transitions determine how the User Program changes state. You can configure inputs, variables, and faults in the I/O Configuration table and use them as transition conditions. Transition conditions support most Boolean operators and timing statements.

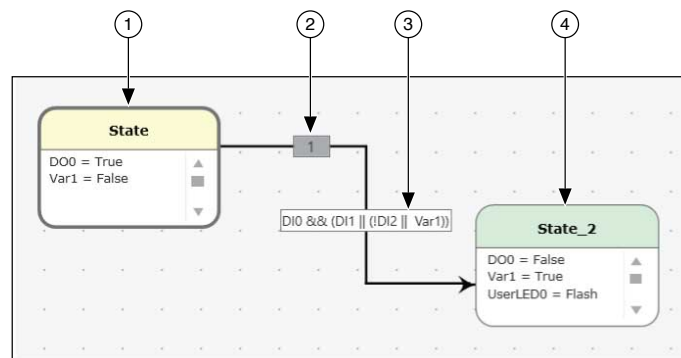
Figure 31. Transition Item Tab



1. Transition icon—The icon and label indicate that a transition is selected.
2. Transition priority pull-down menu—This menu allows you to set the priority number for the selected transition.

3. Transition condition field—This field contains the statement that triggers the selected transition.
4. Documentation—The documentation section provides helpful information about transitions.
5. Detailed documentation link—This link connects to the C Series Functional Safety Manual on [ni.com/manuals](http://ni.com/manuals).

Figure 32. Transitions in the State Machine Diagram

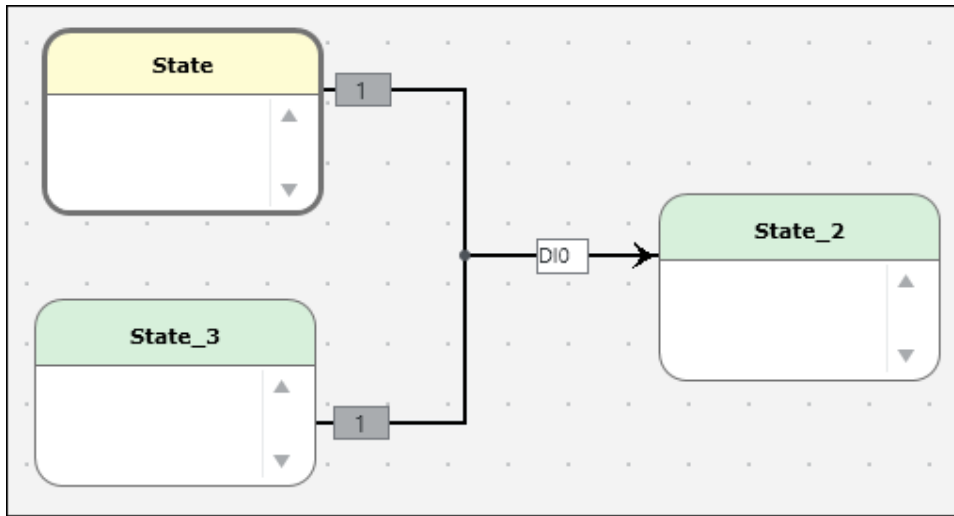


1. Source state
2. Priority number
3. Transition condition
4. Destination state



**Tip** You can join transitions from two or more source states. The priority numbers apply to the individual source states. The transition condition will apply to all joined transitions.

Figure 33. Joined Transitions



#### Related concepts

- [Transition Statements](#)

#### Related tasks

- [Wiring Transitions](#)

#### Transition Statements

The User Program requires transition statements to trigger the User Program to change states. Transition statements include the channel or variable name and a keyword that defines the condition that triggers the transition.

Follow these guidelines when writing transition statements:

- Type logic statements directly into the field on the transition in the state machine diagram or into the field on the configuration pane.
- You must use the channel or variable name set in the I/O Configuration table.
- Keywords and Boolean operators are not case-sensitive.
- Do not use = in transition statements.

Type	Syntax	Keywords	Example
Input	<channel name>.<keyword>	Discrepancyfault Overcurrentfault	DI2.DiscrepancyFault



Type	Syntax	Keywords	Example
		Testpulsefault	
Output	<channel name>.<keyword>	Readbackfault Overcurrentfault Opencircuitfault Testpulsefault	DO1.OpenCircuitFault

Table 16. Digital Transition Statements

Type	Syntax	Keywords	Example
Input	<channel name>.<keyword>	Overcurrentfault Discrepancyfault Discrepancywarning Highhigh, HH High, H Normal, N Low, L Lowlow, LL	AI0.DiscrepancyWarning   AI2.LowLow, AI2.LL

Table 17. Analog Transition Statements (NI 9351 Only)

Type	Syntax	Keywords	Example
Boolean operators	<keyword><channel or variable name> <keyword> <transition statement>	Not: not, !	not DI2, !AI0.High
	<channel or variable name> <keyword> <channel or variable name>	Or: or, +,	DI2 or Var2, AI0.High or AI0.HighHigh
	<keyword> <transition statement>	And: and, *, &&	DI2 and Var2, AI2.High && AI0.DiscrepancyWarning

Table 18. Boolean Logic

### Related concepts

- [Transitions](#)
- [Diagnostics](#)

### Related tasks

- Wiring Transitions

## Timing Transitions

- Each state machine supports up to six timers.
- Timing transitions read as true after a specified time elapses.
- Maximum transition time is 4,096 hours.
- Minimum transition time is constrained by the maximum application processing time: 60  $\mu$ s.

Timer Value	Timer Accuracy	
	Minimum	Maximum
<b>Timer value</b> $\leq$ 4,096 $\mu$ s	<b>Timer value</b> + 30 $\mu$ s	<b>Timer value</b> + 60 $\mu$ s
4,096 $\mu$ s < <b>timer value</b> $\leq$ 4,096 ms		<b>Timer value</b> + 1.06 ms
4,096 ms < <b>timer value</b> $\leq$ 4,096 s		<b>Timer value</b> + 1 s
4,096 s < <b>timer value</b> $\leq$ 4,096 hours		<b>Timer value</b> + 1 hour

Table 40. Timer Accuracy

Type	Syntax	Keywords
Timing Transition	After x <keyword>	us, $\mu$ s, ms, s, min, mins, hr, hrs, day, days

Table 20. Timing Logic

## Transition Priority

The User Program samples all inputs simultaneously. Transitions from a state are evaluated according to transition priority number. The priority number appears on the transition wire next to the transition condition and on the Item tab of the configuration pane. Default transition priority is determined by the order transitions are wired. To update the transition order, select the Transition Priority pull-down menu on the Item tab of the configuration pane.

The User Program evaluates the statement from transition 1 of the current state. If transition 1 evaluates as false, the User Program then evaluates the statement from transition 2. This continues until all transitions have been evaluated or until a transition evaluates as true. If no transition evaluates as true, the User Program remains in the current state for the next application processing loop. If a transition evaluates as true, the User Program updates to the configured state.

Transitions from nested compound states are evaluated from the outermost state to the innermost state. The User Program first evaluates the transitions originating at the border of outermost compound state, in priority order. If none of the transitions evaluate as true, the User Program evaluates the transitions exiting the next nested compound state. This continues until all transitions in the nested compound states have been evaluated. If no transitions from compound states evaluate as true, the User Program evaluates the transitions from the current simple state.

User Programs evaluate transitions in the following order:

1. Transitions from outermost compound state in transition priority order
2. Transitions from each nested compound state in transition priority order
3. Transitions from current state in transition priority order

## Wiring Transitions

Follow these steps to wire transitions in the Functional Safety Editor.

1. Initiate the transition from the source simple state or compound state.
  - To create transitions from a simple state, click the terminal on the state border.
  - To create transitions from a compound state, double-click the border of a compound state to add a state machine tunnel. Then click the terminal on the state machine tunnel.



**Tip** Simple states have twelve terminals for connecting transition. If you need more than twelve connections to or from a single state, consider using a compound state.

2. Complete the transition on the destination simple state or compound state.
  - To complete a transition to a simple state, click the terminal on the state border.
  - To complete a transition to a compound state, click the terminal on the state machine tunnel.



**Note** Every transition must have at least one source state and only one destination state.



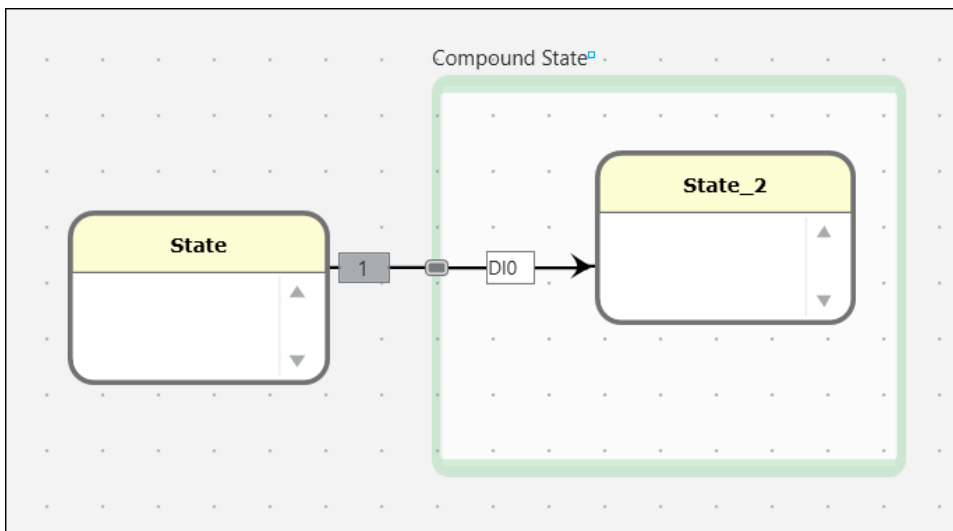
**Note** Transition direction is dependent on wiring order. Make sure you click the source state first and the destination state second.

- Right-click the transition and select **Create transition condition**. You can also click on the **Transition condition** field on the **Item** tab of the configuration pane.



**Note** When a transition wire crosses the border of a compound state, a state machine tunnel creates two wire segments. The Functional Safety Editor only allows transition statements on the wire segment closest to the target state.

Figure 34. Transition Crossing a Compound State Border



- Type the transition statement into the transition condition box on the wire or the **Transition condition** field on the configuration pane. Always follow transition syntax rules.



**Note** You must use the channel name or variable name defined in the Name column of I/O Configuration table. Do not use the name defined in the Hardware name column.



**Tip** In the Functional Safety Editor 2018 or later, transition conditions have a predictive text feature. You can start typing or push <Ctrl-Space> to display a menu of possible channel names and transition statements based on how you configured the I/O configuration table.

### Related concepts

- [Transitions](#)
- [Transition Statements](#)

## Saving and Compiling

User Programs save as .fsp files from the Functional Safety Editor. When you click the Compile button, the editor and compiler generate multiple files. All the generated files will share the filename assigned to the .fsp file.

- **<filename>** .json—Human-readable file that inputs to the compiler. Review this file for correctness.
- **<filename>** .bin—Compiled User Program that is generated by the compiler from the JSON. Download this file to the module from the LabVIEW project.
- **<filename>** \_errors.json—Lists any errors generated by the compiler. This file populates the Errors and Warnings pane. This file is also human-readable and you can review this file for errors.
- **<filename>** \_report.log—Lists additional information about the compiled User Program. You can review this file to verify the channel and fault configurations in your User Program.

You must download the binary User Program file to the C Series Functional Safety module from the properties dialogue of a target module in a project in LabVIEW.

### Related tasks

- [Compiling User Programs](#)
- [Downloading User Programs](#)

## JSON Files

You can use the JSON file output from the editor to verify your User Program before downloading it to the module.

- Refer to the following tables for definitions and parameters when reviewing the JSON.
- Strings (keys and values) are not case sensitive.
- Any JSON element in the file that is not enumerated below will be ignored. If you manually write the JSON file and misspell a key, the key will be ignored as a missing element.

## Type Definitions

- **Identifier string**—A valid UTF-8 Unicode sequence. Each identifier starts with a letter (Unicode general category L), followed by zero or more letters (Unicode general category L), numbers (Unicode general category N), marks (Unicode general category M), and punctuation connectors (Unicode general category Pc).
- **Time string**—A valid UTF-8 Unicode sequence that matches the following regular expression: `\s*\d+\s*[us|µs|ms|s|min|hr|day]\s*`, where `\s` means any spacing character (Unicode general category Z, and the vertical tab, newline, horizontal tab, form feed, and carriage return characters) and `\d` means any decimal digit (Unicode general category Nd).
- **High/Low string**—A string that is either high or low.
- **Boolean string**—A string that is either true or false.
- **OutputDrive string**—A string that is either true, false, passthrough, or flash.

## JSON Definitions

Term	Required?	Type	Notes
version	Yes	Numeric	Must be 1 or 2 if the module_type is 9350. Must be 2 if the module_type is 9351

Term	Required?	Type	Notes
module_type	Yes	String	Must be 9350 or 9351
program_info	Yes	String	Specifies information and settings specific to the program

Table 21. JSON Object Parameters

Term	Required?	Type	Notes
build_number	Yes	Numeric	Increments when you first edit a User Program that has successfully compiled
guid	Yes	GUID string	Formatted with hyphens and braces
auto_start	Yes	Boolean string	Specifies if the program should begin automatically when the module powers on
led_flash_rate	Yes	Time string	Specifies the rate UserLED0 blinks when set to Flash, must be between 50 ms and 12.8 s, inclusive, and be a multiple of 50 ms
fault_latch_time	Yes	Time string	—

Table 31. Program Info Object Parameters

Module_type	Term	Required?	Type	Number of Elements	Definition
9350	digital_inputs	Yes	Array	8	Digital input objects
	digital_outputs	Yes	Array	8	Digital output objects
	variables	Yes	Array	24	Variable objects
	state_machines	Yes	Array	0 to 7 (inclusive)	State tree node objects
9351	digital_inputs	Yes	Array	4	Digital input objects
	digital_outputs	Yes	Array	4	Digital output objects
	analog_inputs	Yes	Array	4	Analog input objects
	variables	Yes	Array	24	Variable objects
	state_machines	Yes	Array	0 to 3 (inclusive)	State tree node objects

Table 23. Module Type Object Parameters

Term	Required?	Type	Notes
alias_name	Yes	Identifier string	—
config_type	Yes	String	Must be one of: reserved, unused, basic, test_pulse, dual, or dual_and_test_pulse

Term	Required?	Type	Notes
discrepancy_time	Required if config_type is dual or dual_and_test_pulse	Time string	—
complementary	Required if config_type is dual or dual_and_test_pulse	Boolean string	—
owner	Required if config_type is reserved	Identifier string	—
test_pulse_width	Required if config_type is test_pulse or dual_and_test_pulse	Time string	—
test_pulse_period	Required if config_type is test_pulse or dual_and_test_pulse	Time string	—
true_value	Required if config_type is basic, test_pulse, dual, or dual_and_test_pulse	String	Must be high or low
debounce_filter_time	Required if config_type is basic, test_pulse, dual, or dual_and_test_pulse	Time string	—
load	Required if config_type is test_pulse, dual_and_test_pulse	Time string	Must have a value of 40 $\mu$ s, 1 ms, 10 ms, or 100 ms (or equivalent).
fail_safe_on_over_current	Required if config_type is test_pulse or dual_and_test_pulse	Boolean string	Can not be true if auto_recover_on_over_current is true. If both failsafe_on_over_current and auto_recover_on_over_current are false, the module will not attempt to recover from the fault.
fail_safe_on_discrepancy	Required if config_type is dual or dual_and_test_pulse	Boolean string	—
fail_safe_on_test_pulse	Required if config_type is test_pulse or dual_and_test_pulse	Boolean string	—
auto_recover_on_over_current	Required if failsafe_on_over_current is false	Boolean string	Can not be true if failsafe_on_over_current is true. If both failsafe_on_over_current and



Term	Required?	Type	Notes
			auto_recover_on_ over_current are false, the module will not attempt to recover from the fault.
over_current_auto_recover_time	Required if auto_recover_on_ over_current is true	Time string	Must have a value between 3 s and 16384 s.

Table 24. Digital Input Object Parameters

Term	Required?	Type	Notes
alias_name	Yes	Identifier string	—
config_type	Yes	String	Must be reserved, unused, basic, test_pulse_internal, test_pulse_external, external_readback, dual, or dual_and_test_pulse_internal, dual_and_test_pulse_external
owner	Required if config_type is reserved	Identifier string	—
test_pulse_width	Required if config_type is test_pulse_internal, test_pulse_external, dual_and_test_pulse_internal, or dual_and_test_pulse_external	Time string	—
test_pulse_period	Required if config_type is test_pulse_internal, test_pulse_external, dual_and_test_pulse_internal, or dual_and_test_pulse_external	Time string	—
readback_delay	Required if config_type is external_readback	Time string	—
load	Required if config_type is basic, test_pulse_internal, test_pulse_external, dual,	Time string	Must have a value of 40 $\mu$ s, 1 ms, 10 ms, or 100 ms (or equivalent).

Term	Required?	Type	Notes
	dual_and_test_pulse_internal, dual_and_test_pulse_external, or external_readback		
flash_rate	Required if config_type is basic, test_pulse_internal, test_pulse_external, dual, dual_and_test_pulse_internal, dual_and_test_pulse_external, or external_readback	Time string	Must have a value that is a multiple of 50 ms, between 50 ms and 12.8 s, inclusive.
debounce_filter_time	Required if config_type is basic, test_pulse_external, external_readback, or dual_and_test_pulse_external	Time string	—
fail_safe_on_over_current	Required if config_type is basic, test_pulse_internal, test_pulse_external, dual, dual_and_test_pulse_internal, dual_and_test_pulse_external, or external_readback	Boolean string	Can not be true if auto_recover_on_over_current is true. If both failsafe_on_over_current and auto_recover_on_over_current are false, the module will not attempt to recover from the fault.
fail_safe_on_open_circuit	Required if config_type is basic, test_pulse_internal, test_pulse_external, dual, dual_and_test_pulse_internal, dual_and_test_pulse_external, or external_readback	Boolean string	
fail_safe_on_discrepancy	Required if config_type is dual, dual_and_test_pulse_internal, or dual_and_test_pulse_external	Boolean string	—
fail_safe_on_test_pulse	Required if config_type is test_pulse_internal, test_pulse_external, dual_and_test_pulse_internal, or dual_and_test_pulse_external	Boolean string	—
fail_safe_on_readback	Required if config_type is basic, external_readback, dual	Boolean string	—

Term	Required?	Type	Notes
auto_recover_on_ over_current	Required if failsafe_on_ over_current is false	Boolean string	Can not be true if failsafe_on_ over_current is true. If both failsafe_on_ over_current and auto_recover_on_ over_current are false, the module will not attempt to recover from the fault.
over_current_auto_ recover_time	Required if auto_recover_on_ over_current is true	Time string	Must have a value between 3 s and 16384 s.

Table 25. Digital Output Object Parameters

Term	Required?	Type	Notes
alias_name	Yes	String	—
config_type	Yes	String	Must be single1oo1, dual1oo2, triple2oo3, reserved, or unused
threshold_lowlow	Required if config_type is analog_input	Numeric	Threshold expressed in nA
threshold_low	Required if config_type is analog_input	Numeric	Threshold expressed in nA
threshold_high	Required if config_type is analog_input	Numeric	Threshold expressed in nA
threshold_highhigh	Required if config_type is analog_input	Numeric	Threshold expressed in nA
discrepancy_time	Required if config_type is dual1oo2 or triple2oo3	Time string	Must have a value between 1000 $\mu$ s and 1800000000 $\mu$ s.
discrepancy_current	Required if config_type is dual1oo2 or triple2oo3	Numeric	The difference between channels required to trigger a discrepancy fault in nA. Value must be greater than 0.
hysteresis	Required if config_type is single1oo1, dual1oo2, or triple2oo3	Numeric	The value by which the analog input must surpass a threshold (above or below) for the channel to be considered in the next region in nA.

Term	Required?	Type	Notes
fail_safe_on_over_current	Required if config_type is single1oo1, dual1oo2, or triple2oo3	Boolean string	—
fail_safe_on_discrepancy	Required if config_type is dual1oo2 or triple2oo3	Boolean string	—

Table 26. Analog Input Object Parameters

Term	Required?	Type	Notes
alias_name	Yes	Identifier string	—
config_type	Yes	String	Must be internal or unused

Table 27. Variable Object Parameters

Term	Required?	Type	Notes
name	Yes	String	—
actions	Yes, but may be empty	Array	Action objects
transitions	Yes, but may be empty	Array	Transition objects
substates	Yes, but may be empty	Array	State tree node objects
initial_state	Optional	Identifier string	—

Table 28. State Machine Object Parameters

Term	Required?	Type	Notes
signal	Yes	Identifier string	—
value	Yes	Output drive string	—

Table 29. Action Object Parameters

Term	Required?	Type	Notes
expression	Yes	Expression string	—
next_state	Yes	Path string	—

Table 30. Transition Object Parameters

## Semantic Definitions

JSON statements must adhere to the following criteria.

- Every signal, state, and state machine must have a unique name.
- Every top-level state machine must have an initial state, and that initial state must be resolvable.
- The next\_state parameter of every transition must refer to a resolvable state.
- No top-level state machine may have more than 32 states.
- The signal parameter of every action object must have the name of a digital output or writable variable.
- The DI and DO channels are dependent. Refer to the following table for the configuration required for each channel pair.

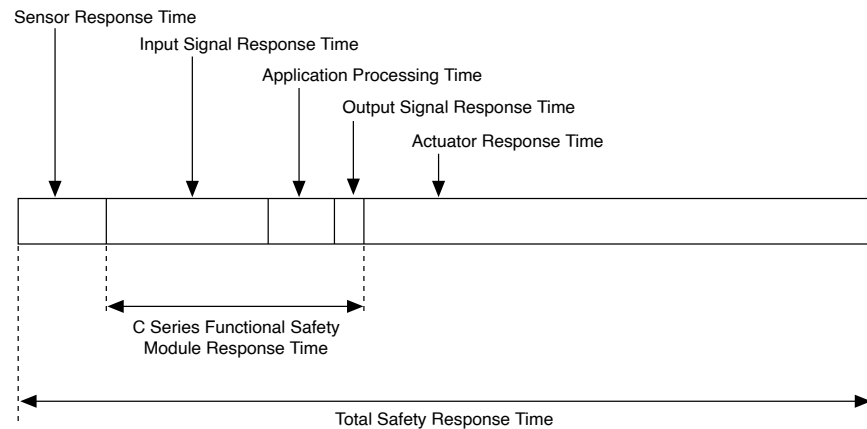
DIn	DIn+1	DO <sub>n</sub>	DO <sub>n+1</sub>
Unused or Basic	Unused or Basic	Unused or Basic	Unused or Basic
Unused or Basic	Reserved	Unused or Basic	External Readback or Test Pulse
Reserved	Unused or Basic	External Readback or Test Pulse	Unused or Basic
Reserved	Reserved	External Readback or Test Pulse	External Readback or Test Pulse
Test Pulse	Unused or Basic	Reserved	Unused or Basic
Test Pulse	Reserved	Reserved	External Readback or Test Pulse
Test Pulse	Test Pulse	Reserved	Reserved
Dual	Reserved	Unused or Basic	Unused or Basic
Dual Test Pulse	Reserved	Reserved	Reserved
Reserved	Reserved	Dual Test Pulse	Reserved
Unused or Basic	Unused or Basic	Dual	Reserved
Dual	Reserved	Dual	Reserved

Table 31. Digital Channel Pair Configurations

## Safety System Response Time

The total safety response time of a C Series Functional Safety module is the delay from the sensor detecting an unsafe condition to the actuator implementing a control to return the system to a safe state.

Figure 35. Safety Response Time



**Note** You must verify the system safety response time before deploying the safety system.

#### Related reference

- [Safety Response Time Specifications](#)

### Calculating Safety System Response Times

Use the following equation to calculate the total safety response time for your C Series Functional Safety system. Optionally, you can use the times in the **C Series Functional Safety Response Time Specifications** section.

**Total safety response time = Sensor response time + Input signal response time + Application processing time + Output signal response time + Actuator response time**

1. Calculate the sensor response time. Refer to the **Sensor Response Time** section.
2. Calculate the input response time. Refer to the **Input Signal Response Time** section.
3. Calculate the diagnostic response time, if applicable. Refer to the **Diagnostic Response Time Specifications** section.

4. Determine the application processing time. This is a guaranteed minimum of 60  $\mu$ s for each state in the defined execution path of the User Program. Refer to the **Application Processing Time** section.
5. Add the output signal response time from the **Response Time Specifications** section.
6. Calculate the actuator response time. Refer to the **Actuator Response Time** section.

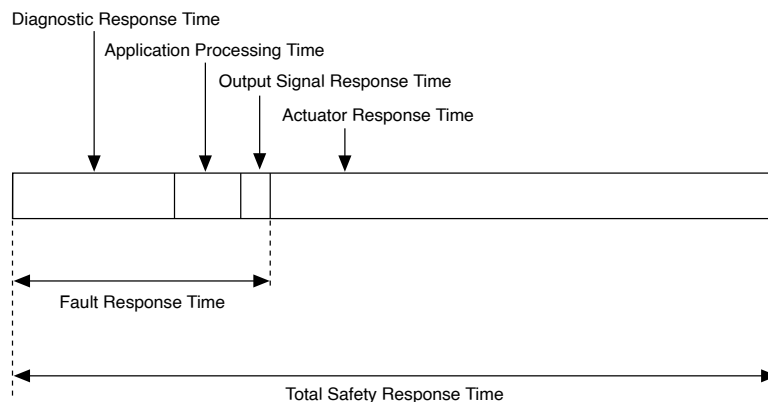
## Fault Response Time

Fault diagnostics run parallel to and independent of the application processes. Faults used as transition conditions in the state machine diagram require the time necessary for fault processing and application processing to set an output response.

- User-configurable diagnostics used as transition conditions:  
**Fault response time = Diagnostic response time +  
 Application processing time + Output signal response time**

Fault response time will vary depending on the execution path defined in the User Program. If the fault triggers a state that sets an output, only one iteration of the application processing time will elapse. Otherwise, the application processing time will increase by the number of states and associated transitions through which the User Program cycles to fully react to the fault.

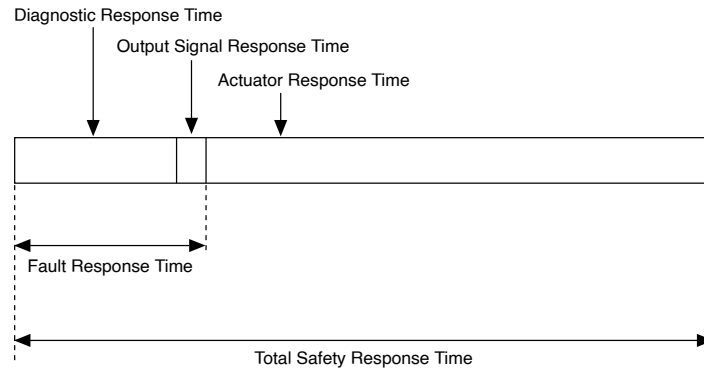
Figure 36. Response Time for Faults Used in Transitions



Faults configured to trigger Fail-safe Mode and automatic self-diagnostics do not require the application processing time. After the fault response time elapses, the module transitions into Fail-safe Mode.

- Automatic self-diagnostics: **Fault response time = Diagnostic response time + Output signal response time**
- User-configurable diagnostics configured to trigger Fail-safe Mode: **Fault response time = Diagnostic response time + Output signal response time**

Figure 37. Response Time to Trigger Fail-Safe Mode and Automatic Self-Diagnostics



Refer to the **Diagnostic Response Time Specifications** to determine the diagnostic response time for your application.

Related concepts

- [Setting Faults to Trigger Fail-Safe Mode](#)

## Sensor Response Time

Sensor Response Time is the total time it takes for sensors to detect an unsafe situation and propagate the input signal to the C Series Functional Safety module. Sensor response times are dependent on the peripheral devices, the safety application, resistors, the length of the cabling, and the total load on the cabling. Refer to the third-party device specifications to calculate sensor response times.



**Note** Make sure you include debounce time for the sensors used in your system. Refer to the third-party device specifications for debounce time.

## Digital Input Signal Response Time

Input signal response time describes the total time it takes to charge or discharge line load capacitance, propagate the signal to the User Program, and pass the signal through the debounce filter.



Use the following equations to calculate input signal response times.

(1 to 0) Input signal response time:

$$\text{Input signal response time} = \text{Input discharge time} + \text{Debounce filter time} + \text{Debounce constant} + 15 \mu\text{s}$$

(0 to 1) Single Input:

$$\text{Input signal response time} = \text{Debounce filter time} + \text{Debounce constant} + 18 \mu\text{s}$$

(0 to 1) Single Input with test pulse:

$$\text{Input signal response time} = (2 \times \text{Debounce filter time}) + (3 \times \text{Debounce constant}) + \text{Test pulse width} + 39 \mu\text{s}$$

(0 to 1) Dual Input:

$$\text{Input signal response time} = \text{Debounce filter time} + \text{Debounce constant} + \text{Discrepancy time} + \text{Discrepancy constant} + 18 \mu\text{s}$$

(0 to 1) Dual Input with test pulse:

$$\text{Input signal response time} = (2 \times \text{Debounce filter time}) + (3 \times \text{Debounce constant}) + \text{Discrepancy time} + \text{Discrepancy constant} + \text{Test pulse width} + 39 \mu\text{s}$$

Debounce filter time, discrepancy time, and test pulse widths are user-configurable parameters in the Functional Safety Editor.

Use the following table to determine the debounce constant based on debounce filter time.

Debounce Filter Time	Debounce Constant
$0 \mu\text{s} \leq \text{debounce filter time} \leq 16,383 \mu\text{s}$	2 $\mu\text{s}$
$16,500 \mu\text{s} \leq \text{debounce filter time} \leq 2,047.875 \text{ ms}$	126 $\mu\text{s}$
$2,125 \text{ ms} < \text{debounce filter time} \leq 5 \text{ s}$	126 ms

Table 40. Debounce Constant

Calculate the input discharge time using the following equation or use recommended input discharge times based on configuration, external load, cable length, and cable capacitance.

$$t = -R \times (C + 600 \text{ pF}) \times \ln\left(\frac{R \times 0.8 \text{ mA} + 5.7 \text{ V}}{R \times 0.8 \text{ mA} + 30 \text{ V}}\right)$$

Configuration	External Load <sup>[1]</sup>	Cable Length/ Capacitance	Input Discharge Time
<ul style="list-style-type: none"> <li>▪ Single output</li> <li>▪ Dual output</li> </ul>	High Impedance	$\leq 10 \text{ m}$ and $\leq 1.8 \text{ nF}$	1,000 $\mu\text{s}$

Configuration	External Load <sup>[1]</sup>	Cable Length/ Capacitance	Input Discharge Time
<ul style="list-style-type: none"> <li>▪ Single output with internal test pulse</li> <li>▪ Dual output with internal test pulse</li> </ul>	High Impedance	≤50 m and ≤9 nF	10,000 μs
	High Impedance	>50 m	100 ms
	≤3 kΩ	≤10 m and ≤1.8 nF	40 μs
	≤3 kΩ	≤50 m and ≤9 nF	1,000 μs
	≤3 kΩ	>50 m	10,000 μs
<ul style="list-style-type: none"> <li>▪ Single output with external test pulse</li> <li>▪ Dual output with external test pulse</li> <li>▪ Single output with external readback</li> <li>▪ Single input with test pulse</li> <li>▪ Dual input with test pulse</li> </ul>	>3 kΩ	≤50 m and ≤9 nF	1,000 μs
	>3 kΩ	>50 m	10,000 μs
	≤3 kΩ	≤50 m and ≤9 nF	40 μs
	≤3 kΩ	>50 m	10,000 μs

Table 33. Recommended Input Discharge Times

<sup>1</sup> When the output load on the DO channel is a DI channel on the same module, load is >3 kΩ.

## Analog Input Signal Response Time

Input signal response time describes the total time it takes to read the analog signal, convert the signal to digital, and propagate the signal to the User Program.

Single input	2 ms
Dual input (1oo2)	2 ms
Triple input (2oo3)	2 ms

## Diagnostic Response Times

Use these specifications and equations to determine diagnostic response times. Diagnostic response times allow you to calculate fault response times for your C Series Functional Safety system.

## Digital Diagnostics

### Open Circuit and Overcurrent Diagnostic Response Time

Open circuit	145 $\mu$ s
Overcurrent	145 $\mu$ s

To calculate open circuit diagnostic response times when using test pulses, use the following equation:

**Open circuit diagnostic response time (with test pulses) = Test pulse width + Test pulse constant + 295  $\mu$ s**

- Test pulse width is a user-configurable parameter in the Functional Safety Editor.
- Use the following table to determine the test pulse constant based on test pulse width.

To calculate overcurrent diagnostic response times when using test pulses, use the following equation:

**Overcurrent diagnostic response time (with test pulses) = Test pulse width + Test pulse constant + 295  $\mu$ s**

- Test pulse width is a user-configurable parameter in the Functional Safety Editor.
- Use the following table to determine the test pulse constant based on test pulse width.

Test Pulse Width	Test Pulse Constant
$\leq 16,384 \mu$ s	1 $\mu$ s
$\geq 16,500 \mu$ s	125 $\mu$ s

Table 34. Test Pulse Constant

### Test Pulse Diagnostic Response Time

Use the following equation to calculate test pulse diagnostic response times.

**Test pulse diagnostic response time = Test pulse period**

- Test pulse period is a user-configurable parameter in the Functional Safety Editor.
- For more information on determining the test pulse period, refer to the **Test Pulses** section.

## Discrepancy Diagnostic Response Time

Use the following equations to calculate discrepancy diagnostic response times.

Discrepancy diagnostic response time (0 to 1)

**Discrepancy diagnostic response time = Discrepancy time + Discrepancy constant + Debounce filter time + Debounce constant + 18  $\mu$ s**

Discrepancy diagnostic response time (0 to 1) with test pulses configured:

**Discrepancy diagnostic response time = (2  $\times$  Debounce filter time) + (3  $\times$  Debounce constant) + Discrepancy time + Discrepancy constant + Test pulse width + 39  $\mu$ s**

Discrepancy diagnostic response time (1 to 0) with or without test pulses configured

**Discrepancy diagnostic response time = Input discharge time + Discrepancy time + Discrepancy constant + Debounce filter time + Debounce constant + 15  $\mu$ s**

- Discrepancy time, debounce filter time, and test pulse width are user-configurable parameters in the Functional Safety Editor.
- For more information about determining the debounce filter time when using test pulses, refer to the **Filter Times for Test Pulses** section.
- For more information on configuring discrepancy times, refer to the **Discrepancy Diagnostics for Digital Inputs** section.
- Use the following table to determine the discrepancy constant based on discrepancy time.

Discrepancy Time	Discrepancy Constant
$100 \mu\text{s} \leq \text{discrepancy time} \leq 16,383 \mu\text{s}$	2 $\mu\text{s}$
$16,500 \mu\text{s} \leq \text{discrepancy time} \leq 2,047.875 \text{ ms}$	126 $\mu\text{s}$
$2,125 \text{ ms} \leq \text{discrepancy time} \leq 30 \text{ s}$	126 ms

Table 40. Discrepancy Constant



**Note** You cannot set discrepancy time to 0  $\mu\text{s}$  when using dual input or dual input with test pulse.

- Use the following table to determine the debounce constant based on debounce filter time.

Debounce Filter Time	Debounce Constant
$0 \mu\text{s} < \text{debounce filter time} \leq 16,383 \mu\text{s}$	2 $\mu\text{s}$
$16,500 \mu\text{s} \leq \text{debounce filter time} \leq 2,047.875 \text{ ms}$	126 $\mu\text{s}$
$2,125 \text{ ms} \leq \text{debounce filter time} \leq 5 \text{ s}$	126 ms

Table 36. Debounce Constant



**Note** You cannot set debounce filter time to 0  $\mu\text{s}$  when using dual input with test pulse.

## Readback Diagnostic Response Time

For single and dual output configurations, use the following times.

Readback diagnostic response times (per output load)	
Very light	150 $\mu\text{s}$
Light	1,100 $\mu\text{s}$
Medium	11,025 $\mu\text{s}$
Heavy	110,150 $\mu\text{s}$

For single outputs configured with external readback, use the following equations to calculate readback diagnostic response times based on output line load.

Output Line Load	Readback Diagnostic Response Time Equation
Very light	<b>Debounce filter time + Debounce constant + Readback delay + Readback constant</b> + 61 $\mu\text{s}$
Light	<b>Debounce filter time + Debounce constant + Readback delay + Readback constant</b> + 1,021 $\mu\text{s}$

Output Line Load	Readback Diagnostic Response Time Equation
Medium	<b>Debounce filter time + Debounce constant + Readback delay + Readback constant</b> + 10,021 $\mu\text{s}$
Heavy	<b>Debounce filter time + Debounce constant + Readback delay + Readback constant</b> + 100,145 $\mu\text{s}$

Table 37. Readback Diagnostic Response Time Equations

- Debounce filter time, readback delay, and output line load are user-configurable parameters in the Functional Safety Editor.
- For more information on configuring readback delay refer to the **Readback Diagnostics** section.
- Use the following table to determine the debounce constant based on the debounce filter time.

Debounce Filter Time	Debounce Constant
$0 \mu\text{s} < \text{debounce filter time} \leq 16,383 \mu\text{s}$	2 $\mu\text{s}$
$16,500 \mu\text{s} \leq \text{debounce filter time} \leq 2,047.875 \text{ ms}$	126 $\mu\text{s}$
$2,125 \text{ ms} \leq \text{debounce filter time} \leq 5 \text{ s}$	126 ms

Table 38. Debounce Constant

- Use the following table to determine the readback constant based on the readback delay.

Readback Delay	Readback Constant
$0 \mu\text{s} \leq \text{readback delay} \leq 16,383 \mu\text{s}$	1 $\mu\text{s}$
$16,500 \mu\text{s} \leq \text{readback delay} \leq 2,047.875 \text{ ms}$	125 $\mu\text{s}$
$2,125 \text{ ms} \leq \text{readback delay} \leq 5 \text{ s}$	125 ms

Table 39. Readback Constant

## Analog Diagnostics (NI 9351 Only)

### Overcurrent Diagnostic Response Time

Overcurrent fault	2 ms
-------------------	------

## Discrepancy Diagnostic Response Time

To calculate discrepancy diagnostic response times, use the following equation.

**Discrepancy response time = discrepancy time + discrepancy constant + 2 ms**

- Discrepancy time is a user-configurable parameter in the Functional Safety Editor.
- Use the following table to determine the discrepancy constant based on discrepancy time.

Discrepancy Time	Discrepancy Constant
$1000 \mu\text{s} \leq \text{discrepancy time} \leq 16,383 \mu\text{s}$	2 $\mu\text{s}$
$16,500 \mu\text{s} \leq \text{discrepancy time} \leq 2,047.875 \text{ ms}$	126 $\mu\text{s}$
$2,125 \text{ ms} \leq \text{discrepancy time} \leq 1800 \text{ s}$	126 ms

Table 40. Discrepancy Constant

## Application Processing Time

Application processing time represents how long the User Program needs to read an input and respond by setting an output. The application processing time consists of one or more application processing loops.

One iteration of the application processing loop takes 30  $\mu\text{s}$ . At the beginning of every loop, the User Program samples inputs and sets outputs based on the current state. When the loop runs, the User Program evaluates transition conditions from the current state against the sampled inputs. If the inputs trigger a transition, the User Program updates to a new state. At the beginning of the next loop, the User Program sets outputs based on the new state.

If an input value changes after the beginning of the loop, that input will not be sampled until the beginning of the next loop. The total application response will require two iterations of the loop and take 60  $\mu\text{s}$ .

Total application processing time increases for each state and associated transition in the defined execution path. Transition timers increase processing time by the number of loops required to resolve the timing logic as true.

## Output Signal Response Time

Output signal response time describes the total time it takes to send the signal from the User Program to the output channel. For a maximum output signal response time, refer to the **Safety Response Time Specifications** section.

## Power Down Response Time

Every DO channel implements redundant FETs to ensure the output channel can de-energize in the case of a single fault. If multiple internal faults occur and both DO FETs on a channel short, the module will go into Power Down Mode and de-energize all outputs. For the maximum power down response time for output self-diagnostics, refer to the **Safety Response Time Specifications** section.

## Actuator Response Time

Actuator response time is the total time it takes for the output to propagate from the C Series Functional Safety module to the actuator and for the actuator to implement a control. Actuator response times are dependent on the peripheral devices, the safety application, resistors, the length of the cabling, and the total load on the cabling.



**Tip** If you calculated the discharge time based on output line load, you can use that time when calculating the actuator response time. The discharge time represents the amount of time it takes the signal to propagate from the C Series Functional Safety module to the actuator.

## Safety Response Time Specifications

Use these specifications to calculate safety response times for your C Series Functional Safety system.



**Note** These specifications list **minimum guaranteed** times unless otherwise noted.



## Total C Series Functional Safety Module Response Time

<b>Digital Configurations</b>	
Single input and dual input	122 $\mu$ s
Single input with test pulse and dual input with test pulse	230 $\mu$ s
<b>Analog Configurations</b>	
Single input (1oo1)	2.065 ms
Dual input (1oo2)	2.065 ms
Triple input (2oo3)	2.065 ms
Application processing time	60 $\mu$ s
Output signal response time <sup>[1]</sup>	5 $\mu$ s, maximum

## Digital Input Signal Response Time

<b>Input signal response time (1 to 0)</b>	
Single or dual input	57 $\mu$ s
Single or dual input with test pulses	165 $\mu$ s



**Note** Input signal response time (1 to 0) assumes a 3 k $\Omega$  external pull-down, 50 m cable length with capacitance <180 pF/m, and the debounce filter and test pulse width set to the minimum values for the given configuration.

<b>Input signal response time (0 to 1)</b>	
Single input	20 $\mu$ s
Dual input	122 $\mu$ s
Single input with test pulses	346 $\mu$ s

Dual input with test pulses

649  $\mu\text{s}$ 

**Note** Input signal response time (0 to 1) assumes the debounce filter, test pulse width, and discrepancy time are set to minimum values for the given configuration.

Input discharge time (1 to 0)

40  $\mu\text{s}$ 

**Note** Input discharge time represents a 30 V to low state voltage threshold crossing. The maximum input discharge time assumes a 3 k $\Omega$  external pull-down, 50 m cable length with a capacitance < 180 pF/m.

## Analog Input Signal Response Time

Single input	2 ms
Dual input (1oo2)	2 ms
Triple input (2oo3)	2 ms

## Automatic Self-Diagnostics Test Interval

Temperature fault	1.01 s
Analog input self-diagnostic faults	2 ms
Other automatic self-diagnostic faults	160 $\mu\text{s}$
Power down response time <sup>[2]</sup>	435 $\mu\text{s}$

## User-Configurable Diagnostic Response Time

### Digital Configurations

Overcurrent	145 $\mu\text{s}$
Open circuit	145 $\mu\text{s}$

Test pulse	340 $\mu$ s and configured with very light load
Internal readback	150 $\mu$ s and configured with very light load
External readback	149 $\mu$ s
Dual input discrepancy	159 $\mu$ s

### Analog Configurations

Overcurrent fault	2 ms
Discrepancy fault	3.002 ms
Discrepancy warning	3.002 ms



**Note** User-configurable diagnostics assume the minimum values for test pulse width, test pulse period, discrepancy time, read back delay, and output line load.

#### Related concepts

- [Safety System Response Time](#)

<sup>1</sup> Includes delay time from a change in safety processing logic output to the digital output turning off. This does not include the discharge time for the output load.

<sup>2</sup> Includes delay time from a change in safety processing logic output until power down activates. This does not include the discharge time for the internal 40  $\mu$ F bulk capacitance or the output load.

## Diagnostics

Diagnostics allow users to test the system periodically to detect and prevent possible unsafe failures. The C Series Functional Safety modules feature user-configurable diagnostics and automatic self-diagnostics.

#### Related concepts

- [Setting Faults to Trigger Fail-Safe Mode](#)
- [Transition Statements](#)

## Digital Input Configurations

Fault	Input Signal Status	
	Low	High
Short to ground	Not detected, safe state	Not detected, safe state
Short to $V_{SUP}$	Not detected	Not detected
Open circuit	Not detected, safe state	Not detected, safe state

Table 54. Single Input

Fault	Switch Condition	
	Open	Closed
Short to ground (test pulse output channel)	Overcurrent fault	Overcurrent fault
Short to $V_{SUP}$ (test pulse output channel)	Not detected, safe state	Test pulse fault
Short to ground (input channel)	Not detected, safe state	Overcurrent fault
Short to $V_{SUP}$ (input channel)	Test pulse fault	Test pulse fault
Open circuit	Not detected, safe state	Not detected, safe state

Table 55. Single Input with Test Pulse

Fault	Input Signal Status	
	Low	High
Short to ground (one channel)	Not detected, safe state	Discrepancy fault
Short to ground (both channels)	Not detected, safe state	Not detected, safe state
Short to $V_{SUP}$ (one channel)	Discrepancy fault	Not detected
Short to $V_{SUP}$ (both channels)	Not detected	Not detected
Channels shorted together	Not detected	Not detected
Open circuit (one channel)	Not detected, safe state	Discrepancy fault
Open circuit (both channels)	Not detected, safe state	Not detected, safe state

Table 56. Equivalent Dual Input

Fault	Input Signal Status	
	Low	High
Short to ground (one channel)	Not detected	Discrepancy fault
Short to ground (both channels)	Discrepancy fault	Discrepancy fault

Fault	Input Signal Status	
	Low	High
Short to $V_{SUP}$ (one channel)	Discrepancy fault	Not detected
Short to $V_{SUP}$ (both channels)	Discrepancy fault	Discrepancy fault
Channels shorted together	Discrepancy fault	Discrepancy fault
Open circuit (one channel)	Not detected	Discrepancy fault
Open circuit (both channels)	Discrepancy fault	Discrepancy fault

Table 44. Complimentary Dual Input

Fault	Switch Condition	
	Open	Closed
Short to ground (one or both test pulse output channels)	Overcurrent fault	Overcurrent fault
Short to $V_{SUP}$ (one or both test pulse output channels)	Test pulse fault	Test pulse fault
Test pulse output channels shorted together	Test pulse fault	Test pulse fault
Short to ground (one or both input channels)	Not detected, safe state	Overcurrent fault
Short to $V_{SUP}$ (one or both input channels)	Test pulse fault	Test pulse fault
Input channels shorted together	Test pulse fault	Test pulse fault
Open circuit (one channel)	Not detected, safe state	Discrepancy fault
Open circuit (both channels)	Not detected, safe state	Not detected, safe state

Table 45. Equivalent Dual Input with Test Pulse

Fault	Switch Condition	
	Open	Closed
Short to ground (one or both test pulse output channels)	Overcurrent fault	Overcurrent fault
Short to $V_{SUP}$ (one or both test pulse output channels)	Test pulse fault	Test pulse fault
Test pulse output channels shorted together	Test pulse fault	Test pulse fault
Short to ground (one input channel)	Not detected	Overcurrent fault
Short to ground (both input channels)	Discrepancy fault	Discrepancy fault
Short to $V_{SUP}$ (one or both input channels)	Test pulse fault	Test pulse fault
Input channels shorted together	Test pulse fault	Test pulse fault
Open circuit (one channel)	Not detected	Discrepancy fault

Fault	Switch Condition	
	Open	Closed
Open circuit (both channels)	Discrepancy fault	Discrepancy fault

Table 46. Complimentary Dual Input with Test Pulse

### Related concepts

- [Digital Configurations](#)

### Digital Output Configurations

Fault	Output Signal Value	
	True	False
Short to ground	Overcurrent fault	Not detected, safe state
Short to $V_{SUP}$	Not detected	Readback fault
Open circuit	Open circuit fault	Not detected, safe state

Table 47. Single Output

Fault	Output Signal Value	
	True	False
Short to ground	Overcurrent fault	Not detected, safe state
Short to $V_{SUP}$	Test pulse fault	Readback fault
Open circuit	Open circuit fault	Not detected, safe state

Table 48. Single Output with Internal Test Pulse

Fault	Output Signal Value	
	True	False
Short to ground (output channel)	Overcurrent fault	Not detected, safe state
Short to $V_{SUP}$ (output channel)	Test pulse fault	Readback fault
Short to ground (input channel)	Overcurrent fault	Not detected, safe state
Short to $V_{SUP}$ (input channel)	Test pulse fault	Readback fault
Open circuit	Open circuit fault	Not detected, safe state

Table 49. Single Output with External Test Pulse

Fault	Output Signal Value	
	True	False
Short to ground (output channel)	Overcurrent fault	Not detected, safe state
Short to $V_{SUP}$ (output channel)	Not detected	Readback fault
Short to ground (input channel)	Overcurrent fault	Not detected, safe state
Short to $V_{SUP}$ (input channel)	Not detected	Readback fault
Open circuit	Open circuit fault	Not detected, safe state

Table 50. Single Output with External Readback

Fault	Output Signal Value	
	True	False
Short to ground (one or both channels)	Overcurrent fault	Not detected, safe state
Short to $V_{SUP}$ (one or both channels)	Not detected	Readback fault
Open circuit (one or both channels)	Open circuit fault	Not detected, safe state

Table 51. Dual Output

Fault	Output Signal Value	
	True	False
Short to ground (one or both channels)	Overcurrent fault	Not detected, safe state
Short to $V_{SUP}$ (one or both channels)	Test pulse fault	Readback fault
Open circuit (one or both channels)	Open circuit fault	Not detected, safe state

Table 52. Dual Output with Internal Test Pulse

Fault	Output Signal Value	
	True	False
Short to ground (output channel)	Overcurrent fault	Not detected, safe state
Short to $V_{SUP}$ (output channel)	Test pulse fault	Readback fault
Short to ground (input channel)	Overcurrent fault	Not detected, safe state
Short to $V_{SUP}$ (input channel)	Test pulse fault	Readback fault
Open circuit	Open circuit fault	Not detected, safe state

Table 53. Dual Output with External Test Pulse

## Related concepts

- Digital Configurations

## Analog Input Configurations (NI 9351 Only)



**Note** Discrepancy fault and discrepancy warning are dependent on the measured current. For a discrepancy fault or warning to occur, the faulted channel must have a current delta with respect to the other channel(s) greater than the configured discrepancy current.

Condition	Resulting Current Region	Diagnostic Fault
Short to ground	Low low	—
Current exceeds specifications	High high	Overcurrent fault
Open circuit	Low low	—
Incorrect sensor output	Current region depends on the current input from the faulted sensor.	—

Table 54. Single Input

Condition	Resulting Current Region	Diagnostic Fault(s)
Short to ground (one channel)	Low low	Discrepancy fault
Short to ground (both channels)	Low low	—
Current exceeds specifications (one channel)	High high unless the other channel is low low.	Overcurrent fault and discrepancy fault
Current exceeds specifications (both channels)	High high	Overcurrent fault
Open circuit (one channel)	Low low	Discrepancy fault
Open circuit (both channels)	Low low	—
Incorrect sensor output (one channel or both channels)	Current region depends on module FPGA voting outcome.	Discrepancy fault

Table 55. Dual Input (1oo2)

Condition	Resulting Current Region	Diagnostic Fault(s)
Short to ground (one channel)	Current region depends on module FPGA voting outcome. Module FPGA assigns low low current region to faulted channel.	Discrepancy warning



Condition	Resulting Current Region	Diagnostic Fault(s)
Short to ground (two channels)	Low low	Discrepancy warning
Short to ground (all channels)	Low low	—
Current exceeds specifications (one channel)	Current region depends on module FPGA voting outcome. Module FPGA assigns high high current region to faulted channel.	Discrepancy warning
Current exceeds specifications (two channels)	High high	Overcurrent fault and discrepancy warning
Current exceeds specifications (all channels)	High high	Overcurrent fault
Open circuit (one channel)	Current region depends on module FPGA voting outcome. Module FPGA assigns low low current region to faulted channel.	Discrepancy warning
Open circuit (two channels)	Low low	Discrepancy warning
Open circuit (all channels)	Low low	—
Incorrect sensor output (one channel)	Current region depends on module FPGA voting outcome.	Discrepancy warning
Incorrect sensor output (two channels or all channels)	Current region depends on module FPGA voting outcome.	Discrepancy fault or discrepancy warning

Table 56. Triple Input (2003)

### Related concepts

- [Analog Configurations \(NI 9351 Only\)](#)
- [Current Threshold Diagnostics](#)
- [Thresholds](#)
- [Discrepancy Current](#)
- [Discrepancy Faults for Analog Input Configurations](#)
- [Discrepancy Warning](#)

## User-Configurable Digital Diagnostics

User-configurable diagnostics allow your User Program to monitor and detect various faults related to your sensors, cabling, and final elements. User-configurable

diagnostics populate the Fault section of the I/O Configuration table in the Functional Safety Editor based on the channel configuration you select. Refer to the following table for the fault options that populate for a selected configuration.

Signal Type	Configuration	Fault Options
Digital Inputs	Single input	No fault options
	Single input with test pulse	Overcurrent fault, test pulse fault
	Dual input	Discrepancy fault
	Dual input with test pulse	Discrepancy fault, overcurrent fault, test pulse fault
Digital Outputs	Single output	Readback fault, overcurrent fault, open circuit fault
	Single output with external readback	Readback fault, overcurrent fault, open circuit fault
	Single output with internal test pulse	Overcurrent fault, open circuit fault, test pulse fault
	Single output with external test pulse	Overcurrent fault, open circuit fault, test pulse fault
	Dual output	Readback fault, overcurrent fault, open circuit fault
	Dual output with internal test pulse	Overcurrent fault, open circuit fault, test pulse fault
	Dual output with external test pulse	Overcurrent fault, open circuit fault, test pulse fault

Table 62. Fault Configuration

## Related concepts

- [Digital Configurations](#)

## Test Pulses

You can configure internal or external test pulses on all digital signals. Test pulses verify that a line can be de-energized or driven to a safe state.

- For outputs with test pulses, DOn is available to use in the state machine diagram. The User Program will return test pulse faults on DOn.TestPulseFault.

- For inputs with test pulses, DOn is reserved and is not available to use in state machine diagram. The User Program will return test pulse faults on DIn.TestPulseFault.



**Note** Test pulses always pulse low.



**Note** Dual input and dual output configurations with test pulses are staggered to monitor for channel to channel shorts.



**Note** The User Program runs both readback diagnostics and test pulse diagnostics when you configure test pulses. Readback faults and test pulse faults report as a single event in the User Program. If you configure a channel with DIn.TestPulseFault or DOn.TestPulseFault, a test pulse fault or a readback fault would trigger a response. Scan Interface reports readback faults and test pulse faults as unique events. Scan Interface will report whether a readback fault or a test pulse fault triggered that response.



**Note** Make sure test pulse width does not cause the final element or safety actuator to switch off.

You can use test pulse faults in two ways:

- You can check the Module failsafe box for DIn.TestPulseFault or DOn.TestPulseFault. If a test pulse fault occurs, the module will go into Fail-safe Mode.
- You can use DIn.TestPulseFault or DOn.TestPulseFault in the transition condition on the State Machine Diagram. If a test pulse fault occurs, the User Program will transition to a user-configured state.

### Configuring Test Pulses

Test pulses are defined by four configurable parameters in the I/O Configuration table. You can modify these parameters to meet the application requirements for your system.

- Output line loading

- Test pulse width
- Test pulse period
- Debounce filter

You can constrain the test pulse width and test pulse period to reduce inaccuracy and uncertainty. You must configure the test pulse width and test pulse period based on your output line load. Refer to the **Test Pulse Parameters** section for suggested parameter values.

Follow these steps to configure test pulses.

1. Set output line loading based on configuration. Refer to the **Output Line Load Recommendations** table in the **Output Line Load** section.
2. Set the minimum test pulse width based on output line loading. Setting the smallest possible test pulse width minimizes the input signal response time. Refer to the **Minimum test pulse parameters** table in the **Test pulse parameters** section.
3. Set the test pulse period to greater than or equal to four times the test pulse width.  
**Test pulse period**  $\geq 4 \times$  **Test pulse width**
4. Set the debounce filter based on the output loading and the test pulse parameters. Refer to the **Filter Times for Test Pulses** section.

#### Test Pulse Parameters

Use these parameter values to configure minimum test pulse widths and periods based on output loading.

Output Loading	Test Pulse Width	Test Pulse Period
Very Light	85 $\mu$ s	340 $\mu$ s
Light	1.045 ms	4.18 ms
Medium	10.045 ms	40.25 ms
Heavy	100.125 ms	400.5 ms

Table 58. Minimum Test Pulse Parameters

## Filter Times for Test Pulses

Use the following equations to calculate the minimum debounce filter times for test pulses based on output loading.

Output Loading	Test Pulse Width $\leq 16,384 \mu\text{s}$	Test Pulse Width $\geq 16,500 \mu\text{s}$
Very Light	<b>Debounce filter time <math>\geq</math> test pulse width</b> + 23 $\mu\text{s}$	<b>Debounce filter time <math>\geq</math> test pulse width</b> + 147 $\mu\text{s}$
Light		
Medium		
Heavy	<b>Debounce filter time <math>\geq</math> test pulse width</b> + 271 $\mu\text{s}$	

Table 59. Minimum Debounce Filter Times

You must confine the maximum debounce filter time for the following configurations to ensure that the debounce filter will not filter out the remaining high time of the input period. Use the following equations to calculate the maximum debounce filter times for test pulses based on output loading.

Output Loading	Test Pulse Width $\leq 16,384 \mu\text{s}$	Test Pulse Width $\geq 16,500 \mu\text{s}$
Very Light	<b>Debounce filter time <math>&lt;</math> test pulse period</b> - <b>Test pulse width</b> - 23 $\mu\text{s}$	<b>Debounce filter time <math>&lt;</math> test pulse period</b> - <b>test pulse width</b> - 147 $\mu\text{s}$
Light		
Medium		
Heavy	<b>Debounce filter time <math>&lt;</math> test pulse period</b> - <b>test pulse width</b> - 271 $\mu\text{s}$	

Table 60. Maximum Debounce Filter Times

## Readback Diagnostics

- Internal readback diagnostics are available on both Single output and Dual output configurations. When you select one of these configurations, DOn.ReadbackFault will populate the Faults table.
- Internal readback monitors the output signal and compares it to the configured output value in the User Program. If the output does not match the configured value, the User Program will return a fault on DOn.Readbackfault.
- External readback diagnostics are available for single outputs. Select the Single output with external readback in the configuration column.

- External readback monitors digital output signals for expected values. You can configure the readback delay to accommodate the time it takes for the signal to propagate. If the output signal does not match the expected value, the User Program will return a fault on DOn.Readbackfault.
  - You can set a maximum time for output values to propagate to the input channel.
  - A readback fault occurs when the propagation exceeds the defined maximum time limit.
  - To turn off readback delay, set value to 0.
  - Toggling outputs faster than the readback diagnostic response time will result in loss of the readback diagnostic.
  - If you set a digital output signal to Flash, you must configure the flash period larger than two times the readback diagnostic response time. **Flash period = 2 × Readback diagnostic response time**
- You can monitor external readback diagnostics anywhere on the output circuit, before or after the actuator.

You can use readback faults in two ways:

- You can check the Module failsafe box for DOn.ReadbackFault. If a readback fault occurs, the module will go into Fail-safe Mode.
- You can use DOn.ReadbackFault in the transition condition on the State Machine Diagram. If a readback fault occurs, the User Program will transition to a user-configured state.

## Overcurrent Diagnostics (Digital)

You can enable overcurrent diagnostics for:

- Digital outputs in any configuration
- Digital inputs configured with test pulses

When the current on the configured channel exceeds module specifications, the module will respond based on how you configured the overcurrent fault. The pull-down menu in the overcurrent recovery column of the Faults table allows you to choose from three different responses for an overcurrent fault.

- **Failsafe**—The module goes into Fail-safe Mode.
- **Auto recover**—The channel de-energizes and the User Program returns a fault on `DOn.OvercurrentFault` or `DIn.OvercurrentFault`. You can use the fault as a transition condition on the state machine diagram. If an overcurrent fault occurs, the User Program will transition to a user-configured state. After the Recovery time elapses, the fault will clear, allowing the user to energize the output again. If the current remains in an overcurrent state, the channel will de-energize again. The de-energize and auto recover cycle will continue until the module no longer reads an overcurrent condition.
- **No recover**—The channel de-energizes and the User Program returns a fault on `DOn.OvercurrentFault` or `DIn.OvercurrentFault`. You can use the fault as a transition condition on the state machine diagram. If an overcurrent fault occurs, the User Program will transition to a user-configured state. The digital output channel on which the fault occurred will de-energize. You must cycle  $V_{sup}$  power to the module to re-energize the channel.

#### Related concepts

- [Overcurrent Recovery \(Digital Configurations\)](#)

#### Open Circuit Diagnostics

You can enable open circuit diagnostics on any digital output channel. If the output channel is energized and the current falls below open circuit detection specifications, the User Program will return a fault on `DOn.OpenCircuitFault`.

You can use open circuit faults in two ways:

- You can check the Module failsafe box for `DOn.OpenCircuitFault`. If an open circuit fault occurs, the module will go into Fail-safe Mode.
- You can use `DOn.OpenCircuitFault` in the transition condition on the State Machine Diagram. If an open circuit fault occurs, the User Program will transition to a user-configured state.

#### Discrepancy Diagnostics for Digital Inputs

You can configure discrepancy diagnostics on consecutive even and odd digital input channels (`DIn` and `DIn+1`). Select the dual input configuration on the even-numbered channel (`DIn`) in the I/O Configuration table. The discrepancy diagnostic

monitors both channels. If a discrepancy occurs, the User Program returns a fault on `DIn.DiscrepancyFault`.

If you configure the channels as equivalent inputs, both channels must be in the same state after the discrepancy time elapses. If you configure the channels as complementary inputs, the two channels must be in opposite states before the discrepancy time elapses.

The User Program returns discrepancy faults on the even-numbered channel (`DIn`). You can use discrepancy faults in two ways:

- You can check the Module failsafe box for `DIn.DiscrepancyFault`. If a discrepancy fault occurs, the module will go into Fail-safe Mode.
- You can use `DIn.DiscrepancyFault` in the transition condition on the State Machine Diagram. If a discrepancy fault occurs, the User Program will transition to a user-configured state.

## Safe State

C Series Functional Safety modules are designed for use in De-Energize to Trip functions. A de-energized (low) state represents the safe state for a given channel. Refer to the following table for channel safe states and user program input values based on configuration and true value.

Discrepancy Fault Configuration	True Value	DI Even ( <code>DIn</code> ) Safe State	DI Odd ( <code>DIn+1</code> ) Safe State	User Program Input Value ( <code>DIn</code> )
Equivalent	Active high	Off	Off	False
	Active low	Off	Off	True
Complementary	Active high	Off	On	False
	Active low	Off	On	True

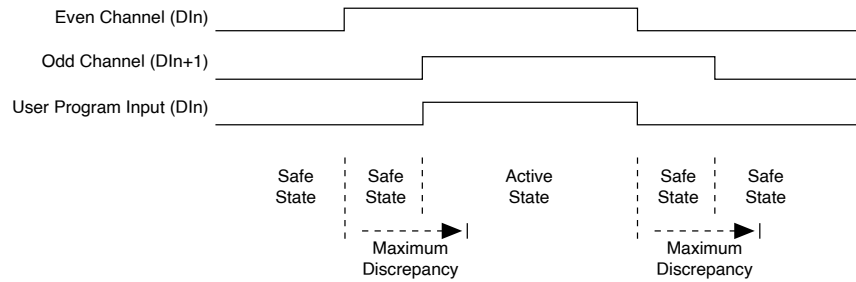
Table 61. Channel Safe States for Discrepancy Configurations

## Equivalent Inputs with Active High True Value

If you select active high on equivalent inputs, low is the safe state for both the even-numbered channel (`DIn`) and the odd-numbered channel (`DIn+1`). If both inputs go high, the User Program returns a fault on `DIn.DiscrepancyFault`.



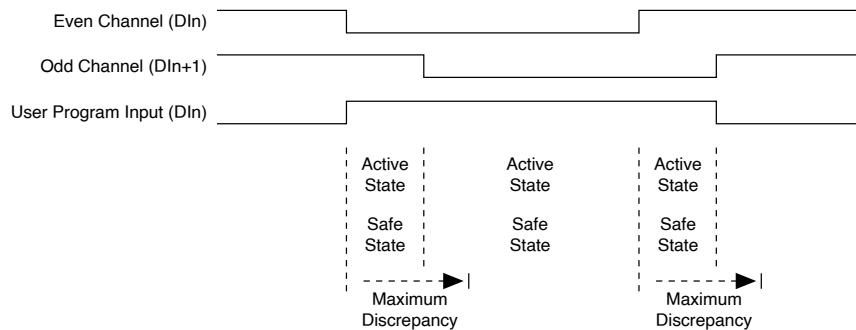
Figure 38. Equivalent Inputs with Active High True Value



### Equivalent Inputs with Active Low True Value

If you select active low on equivalent inputs, high is the safe state for both the even-numbered channel (DIn) and the odd-numbered channel (DIn+1). If either input goes low, the User Program returns a fault on DIn.DiscrepancyFault.

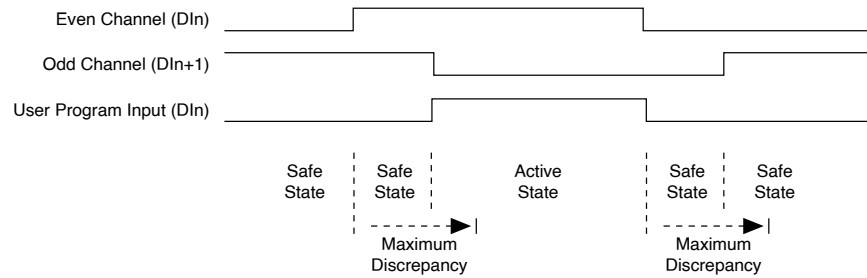
Figure 39. Equivalent Inputs with Active Low True Value



### Complementary Inputs with Active High True Value

If you select active high on complementary inputs, low is the safe state for the even-numbered channel (DIn) and high is the safe state for the odd-numbered channel (DIn+1). If both inputs go into an active state, the User Program returns a fault on DIn.DiscrepancyFault.

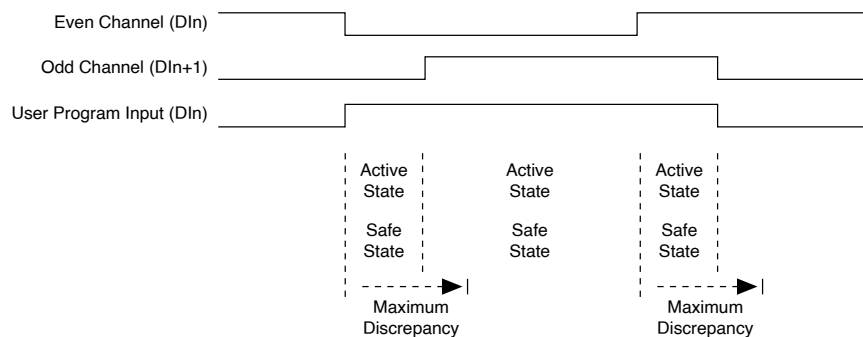
Figure 40. Complementary Inputs with Active High True Value



## Complementary Inputs with Active Low True Value

If you select active low on complementary inputs, high is the safe state for the even-numbered channel (DIn) and the low is the safe state for the odd-numbered channel (DIn+1). If either input goes into an active state, the User Program returns a fault on DIn.DiscrepancyFault.

Figure 41. Complementary Inputs with Active Low True Value



**Note** If one input channel toggles twice while the other input channel remains the same, the User Program returns a fault on DIn.DiscrepancyFault. This diagnostic is monitored post-debounce filter.

## User-Configurable Analog Diagnostics (NI 9351 Only)

User-configurable diagnostics allow your User Program to monitor and detect various faults related to your sensors, cabling, and final elements. User-configurable diagnostics populate the Fault section of the I/O Configuration table in the Functional Safety Editor based on the channel configuration you select. Refer to the following table for the fault options that populate for a selected configuration.

Configuration	Fault Options
Single input	Overcurrent fault
Dual input (1oo2)	Overcurrent fault, discrepancy fault
Triple input (2oo3)	Overcurrent fault, discrepancy fault, discrepancy warning

Table 62. Analog Fault Configuration

### Related concepts

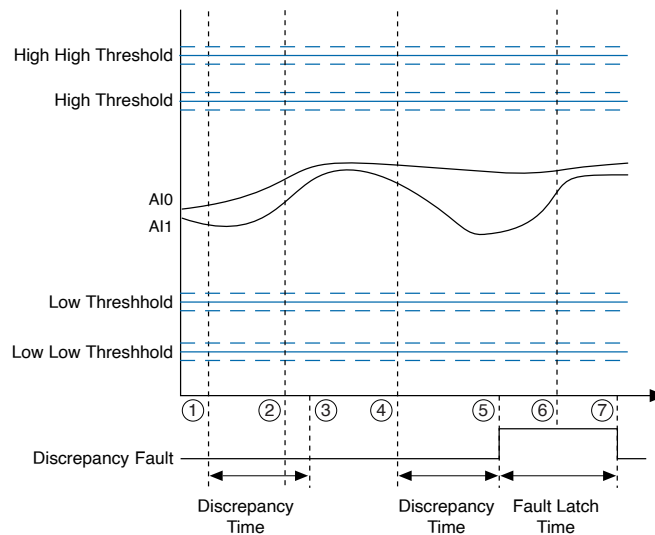
- [Analog Configurations \(NI 9351 Only\)](#)

### Discrepancy Faults for Analog Input Configurations

The module FPGA returns a Discrepancy Fault to the User Program in the following situations:

- In a dual input (1oo2) configuration the two channels read currents that differ by more than the Discrepancy Current for a time greater than the Discrepancy Time.
- In a triple input (2oo3) configuration all three channels read currents that differ from each other by more than the Discrepancy Current for a time greater than the Discrepancy Time.

Figure 42. Discrepancy Fault Signal Diagram



1. Measured currents exceed discrepancy parameter limits.
2. Measured currents return to defined parameter limits.

3. Discrepancy time expires. Since measured currents are within defined parameter limits, the module FPGA does not generate a discrepancy fault.
4. Measured currents exceed discrepancy parameter limits.
5. Discrepancy time expires. Since measured currents still exceed parameter limits, the module FPGA asserts a discrepancy fault and the fault latch timer starts.
6. Measured currents return to defined parameter limits.
7. Fault latch time expires. Since measured currents are within defined parameter limits, the module FPGA no longer asserts a discrepancy fault.



**Tip** To ensure that the module detects and responds to discrepancy faults, set the discrepancy current parameter as low as the system will allow.



**Note** You must set the discrepancy current greater than 0 mA.

You can use discrepancy faults in two ways:

- You check the Module failsafe box for `In.DiscrepancyFault`. If a discrepancy fault occurs, the module will go into Fail-safe Mode.
- You can use `In.DiscrepancyFault` in the transition condition on the state machine diagram. If a discrepancy fault occurs, the User Program will transition to a user-configured state.

Related concepts

- [Discrepancy Time \(Analog Configurations\)](#)
- [Discrepancy Current](#)

Related reference

- [Analog Input Configurations \(NI 9351 Only\)](#)

Discrepancy Warning

Discrepancy Warnings are only used in Triple Input (2003) configurations. The module FPGA returns a Discrepancy Warning to the User Program when one of the

three input channels read a current discrepancy that exceeds the defined parameters.



**Tip** To ensure that the module detects and responds to discrepancy warnings, set the discrepancy current parameter as low as the system will allow.



**Note** You must set the discrepancy current greater than 0 mA.

You can use `Aln.DiscrepancyWarning` as a transition condition on the state machine diagram. If a discrepancy warning fault occurs, the User Program will transition to a user-configured state.

Related concepts

- [Discrepancy Time \(Analog Configurations\)](#)
- [Discrepancy Current](#)

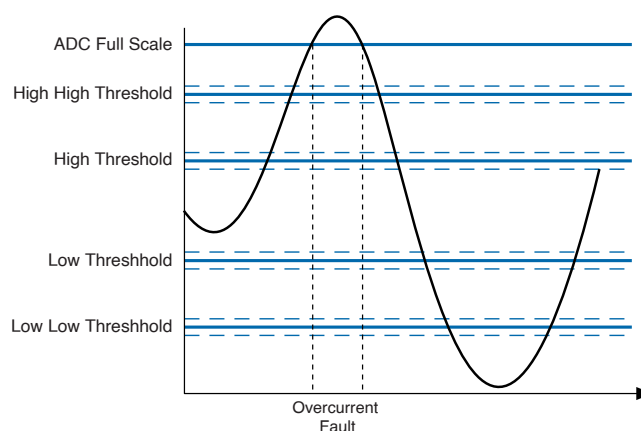
Related reference

- [Analog Input Configurations \(NI 9351 Only\)](#)

Overcurrent Diagnostics (Analog)

Each analog input configuration has overcurrent detection. Overcurrent diagnostics in dual input and triple input configurations use the same voting strategy as threshold diagnostics. For more information on voting strategies, refer to the **Voting Strategies in Dual Input (1002) and Triple Input (2003) Configurations** section. An overcurrent condition occurs any time the input current exceeds the largest current the channel ADC can digitize, shown as ADC Full Scale in the following figure.

Figure 43. Overcurrent Signal Diagram



- In dual input (10o2) configurations, an overcurrent condition on one or two channels will generate an overcurrent fault.
- In triple input (20o3) configurations, an overcurrent condition on two or three channels will generate an overcurrent fault.

The User Program will read overcurrent faults based on configuration.

Analog Configuration	Available Overcurrent Faults
Single input (10o1)	AI $n$ .OvercurrentFault, where $n$ is the number of the channel configured for single input
Dual input (10o2)	AI0.OvercurrentFault or AI2.OvercurrentFault (the even-numbered channel of dual input channel pair)
Triple input (20o3)	AI0.OvercurrentFault only

Table 63. Overcurrent Faults for Analog Configurations

Scan Interface will read overcurrent faults for each individual channel, regardless of configuration. In a triple input (20o3) configuration, a single channel in an overcurrent condition will not generate an overcurrent fault in the User Program, but will report an overcurrent fault for that channel on the Check Channel Status method in LabVIEW.

You can use overcurrent faults in two ways:

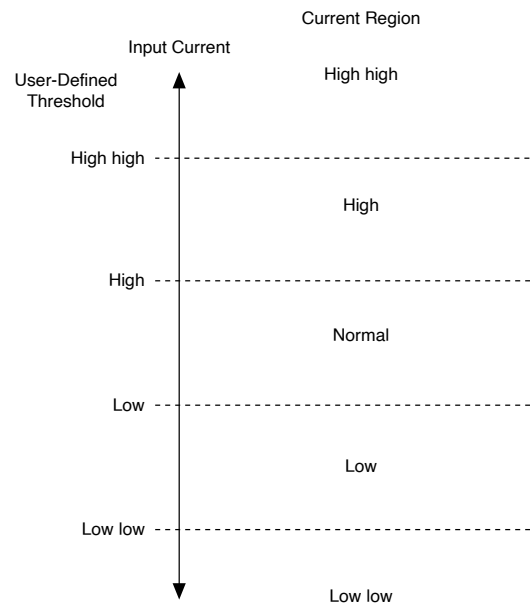
- You check the **Module failsafe** box for AI $n$ .OvercurrentFault. If an overcurrent fault occurs, the module will go into Fail-safe Mode.

- You can use `AIn.OvercurrentFault` in the transition condition on the state machine diagram. If an overcurrent fault occurs, the User Program will transition to a user-configured state.

## Current Threshold Diagnostics

The C Series Functional Safety module uses five current regions to describe the state of the current input to the channel. You define these regions by setting four current thresholds in the Functional Safety Editor.

Figure 44. Current Regions

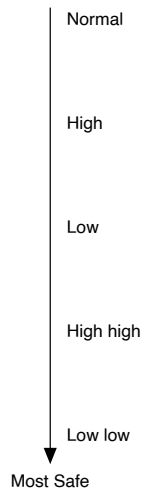


The module FPGA converts current inputs into digital signals to return the current region defined by the configured thresholds. The User Program only reads one current region for each analog configuration. If all the channels in a dual input or triple input configuration read the same current region, the module FPGA returns that current region. If one or more of the channel readings comes back in different current regions than the module FPGA implements a voting strategy to determine which current region to return to the User Program.

C Series Functional Safety modules employ the De-Energize to Trip principle, so the voting strategy defines the Low low as the most safe current region. The second most safe current region is high high because high high could be a result of a fault such as short to  $AI V_{sup}$  or overcurrent.

Refer to the following image for the evaluation of most safe current regions that the module FPGA uses to resolve voting situations.

Figure 45. Current Region Voting Strategy



**Tip** To ensure the module FPGA returns a low low region for a channel, set the low low threshold high enough to filter out inaccuracy and noise.

#### Related concepts

- [Thresholds](#)
- [Hysteresis](#)

#### Related reference

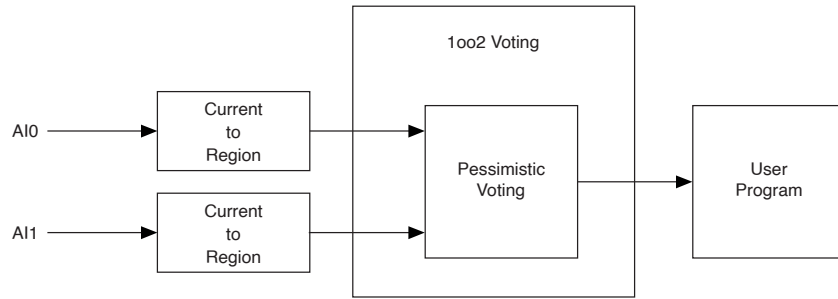
- [Analog Input Configurations \(NI 9351 Only\)](#)

#### Voting in Dual Input (1oo2) Safety Architectures

The module FPGA employs a pessimistic voting strategy in a dual input (1oo2) architecture. When the module reads different currents on the two configured channels, the module FPGA will return the safest region of the two.

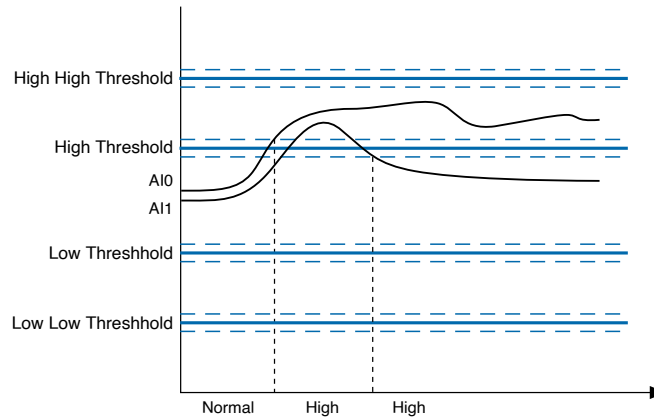


Figure 46. Dual Input (1oo2) Voting



1. The C Series Functional Safety module reads the current on the two input channels.
2. The module FPGA assigns a current region to each channel based on the configured thresholds.
3. If the channels are in the same current region, the voting selects that region. If not, the voting selects the most safe of the two current regions.
4. The User Program uses the single current region selected and returned by the voting strategy.

Figure 47. Dual Input (1oo2) Signal Diagram



The following table shows the voting results for each combination of current regions in a dual input configuration.

AI <sub>n</sub> Current Region	AI <sub>n+1</sub> Current Region	Region Returned to the User Program
High high	High high	High high
High high	High	High high
High high	Normal	High high

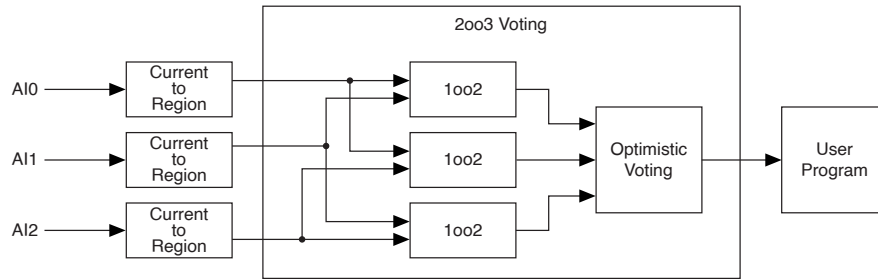
AIn Current Region	AIn+1 Current Region	Region Returned to the User Program
High high	Low	High high
High high	Low low	Low low
High	High high	High high
High	High	High
High	Normal	High
High	Low	Low
High	Low low	Low low
Normal	High high	High high
Normal	High	High
Normal	Normal	Normal
Normal	Low	Low
Normal	Low low	Low low
Low	High high	High high
Low	High	Low
Low	Normal	Low
Low	Low	Low
Low	Low low	Low low
Low low	High high	Low low
Low low	High	Low low
Low low	Normal	Low low
Low low	Low	Low low
Low low	Low low	Low low

Table 65. Dual Input (1oo2) Voting

### Voting in Triple Input (2oo3) Safety Architectures

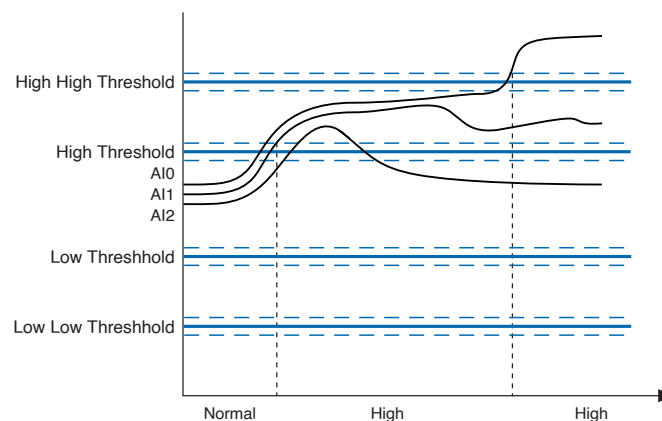
In a 2oo3 architecture, the module FPGA employs a two step voting process before returning a current region to the User Program.

Figure 48. Triple Input (2oo3) Voting



1. The C Series Functional Safety module reads the current on three input channels.
2. The module FPGA assigns a current region to each channel based on the configured thresholds.
3. The module FPGA employs a pessimistic voting strategy to compare the current regions between each pair of channels: 0 and 1, 1 and 2, 0 and 2.
4. The voting strategy selects the most safe current region of each channel pair to produce three reference regions.
5. The module FPGA employs an optimistic voting strategy to compare the three reference regions. The voting strategy selects the least safe reference region of the three.
6. The User Program reads the single current region selected and returned by the module FPGA.

Figure 49. Triple Input (2oo3) Signal Diagram



The following table shows the current region returned to the User Program for each unique combination of inputs.

Current Region Combinations			Region Returned to the User Program
High high	High high	High high	High high
High high	High high	High	High high
High high	High high	Normal	High high
High high	High high	Low	High high
High high	High high	Low low	High high
High high	High	High	High
High high	High	Normal	High
High high	High	Low	Low
High high	High	Low low	High high
High high	Normal	Normal	Normal
High high	Normal	Low	Low
High high	Normal	Low low	High high
High high	Low	Low	Low
High high	Low	Low low	High high
High high	Low low	Low	High high
High high	Low low	Low low	Low low
High	High	High	High
High	High	Normal	High
High	High	Low	High
High	High	Low low	High
High	Normal	Normal	Normal
High	Normal	Low	High
High	Normal	Low low	High
High	Low	Low	Low
High	Low	Low low	Low
High	Low low	Low low	Low low
Normal	Normal	Normal	Normal
Normal	Normal	Low	Normal
Normal	Normal	Low low	Normal
Normal	Low	Low	Low
Normal	Low	Low low	Low

Current Region Combinations			Region Returned to the User Program
Normal	Low low	Low low	Low low
Low	Low	Low	Low
Low	Low	Low low	Low
Low	Low low	Low low	Low low
Low low	Low low	Low low	Low low

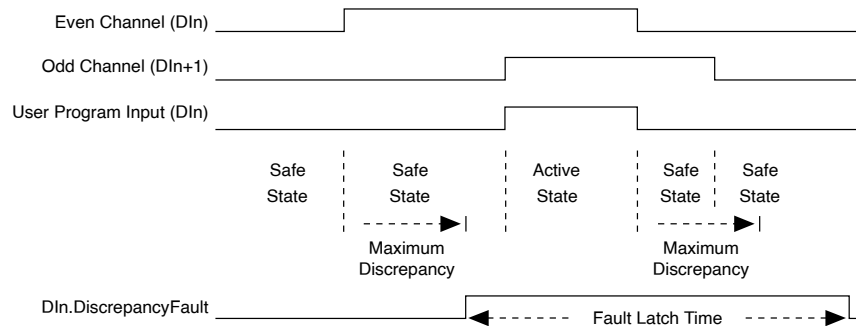
Table 65. Triple Input (2oo3) Voting

## Fault Latching

C Series Functional Safety modules latch detected faults. Fault latch time is a programmable parameter on the Module and Diagram tab of the configuration pane. The NI 9350 has a single fault latch timer which resets for any fault.

The NI 9351 has two fault latch timers. One for digital faults and one for analog faults. The fault latch time parameter applies to both fault timers. Digital faults will not reset the analog fault time and analog faults will not reset the digital fault time.

Figure 50. Fault Latch Time on Discrepancy Faults



Latched faults persist until the configured latch time has elapsed. Detected faults will remain latched when the operational mode changes from Verification Mode to Operational Mode or from Operational Mode to Verification Mode. When the User Program restarts, a latched fault from the previous mode can trigger Fail-safe Mode or transition the User Program to a new state.



**Tip** To monitor faults through Scan Interface, set the fault latch time larger than the Scan Interface scan rate.

## Automatic Self-Diagnostics

C Series Functional Safety modules run a range of automatic self-diagnostics that continuously check for module hardware and power supply faults. Automatic self-diagnostic faults send the module into Fail-safe Mode. The Check Module Status method in LabVIEW will return an Internal Error or Temperature Fault, depending on the fault.

Some of the automatic self-diagnostics implemented by all C Series Functional Safety modules include:

- DI reference compares
- Redundant DO FETs
- Watchdog timers custom-designed for high accuracy
- Internal temperature monitoring
- Power supply voltage monitoring on external supply and all internal rails
- Redundant ADC, signal conditioning and muxes on AI channels
- Range checks on AI channels
- High accuracy AI reference compares



**Note** Errors detected by automatic self-diagnostics on analog configurations will assign a low low current region to all affected channels and generate a flashing pattern on the Internal Fault LED.



**Tip** Every DO channel implements redundant FETs and meets SIL3 capability. To create additional redundancy on DO channels, only connect loads above 20 mA. If both FETs fail in the closed position, the open circuit diagnostic will return a fault.

### $V_{sup}/$ Status LED

The  $V_{sup}/$ Status LED is green and indicates the status of the C Series Functional Safety Module and the User Program.

LED Color	LED Pattern	Module Status	User Program Status
Green	On	Operational Mode	Running

LED Color	LED Pattern	Module Status	User Program Status
	Flashing	Operational Mode	Not running
		Verification Mode	Running
		Verification Mode	Not running
		—	No User Program downloaded
		User Program Download Mode	—
		Fail-safe Mode	Not running
		Upgrading firmware	—
Off	Powered off	—	

Table 68.  $V_{sup}$ /Status LED Flash Behavior

### Internal Fault LED

The Internal Fault LED is red and indicates the module is in Fail-safe Mode. This includes Fail-safe Mode triggered by automatic self-diagnostic faults or user-configurable diagnostic faults.

LED Color	LED Pattern	Indication
Red	Flashes once then pauses	A user-configured fault has triggered Fail-safe Mode.
	Flashes twice then pauses	A temperature fault has been detected.
	Flashes three times then pauses	A power fault has been detected.
	Flashes more than three times then pauses	An internal fault has been detected. Record the number of flashes and contact National Instruments.
	Off	No Internal Fault has been detected.

Table 68. Internal Fault LED Flash Behavior

### I/O Fault LED

The I/O Fault LED is red and indicates faults on I/O channels. The I/O Fault LED displays both a fault code and a channel code. You will first see a series of short flashes that indicate the fault type, then a series of long flashes that indicate the channel number.

Long flashes indicate channel number so that  **$n + 1$  flashes = channel  $n$** .

For example, a test pulse or readback fault on DO2 will cause the I/O Fault LED to display the following flash pattern: Two short flashes + pause + three long flashes

LED Pattern	Indication
Flashes once then pauses	An overcurrent fault has been detected on a digital input or digital output channel.
Flashes twice then pauses	A test pulse or readback fault has been detected.
Flashes three times then pauses	A discrepancy fault has been detected on a digital dual input configuration.
Flashes four times then pauses	An overcurrent fault has been detected on an analog input channel.
Flashes five times then pauses	A discrepancy fault has been detected on an analog dual input or triple input configuration.
Off	No I/O Fault has been detected.

Table 68. I/O Fault LED Fault Code

## UserLED0

- UserLED0 behavior is user-configurable.
- Enable or disable the LED and set the flash period in the I/O Configuration.
- Set the output value of UserLED0 in the state machine diagram.

## Finding Resources

### Developing a Functional Safety System

- Tutorials—For tutorials on developing state machines, go to [ni.com/info](http://ni.com/info) and enter Info Code safetytutorial.
- Whitepapers—For whitepapers with detailed information about creating a Functional Safety system, go to [ni.com/info](http://ni.com/info) and enter Info Code safetypapers.
- Videos—For videos about using C Series Functional Safety modules, go to [ni.com/info](http://ni.com/info) and enter Info Code safetyvideo.

### Using the Hardware

- Hardware documentation—For getting started guides, datasheets, user manuals, and other hardware documentation for CompactRIO controllers and the C Series Functional Safety modules, visit [ni.com/manuals](http://ni.com/manuals).



## Using LabVIEW

- **LabVIEW Help**—Use the LabVIEW Help to access information about LabVIEW programming concepts, step-by-step instructions for using LabVIEW, and reference information about LabVIEW VIs, functions, palettes, menus, tools, properties, methods, events, dialog boxes, and so on. The LabVIEW Help also lists the LabVIEW documentation resources available from National Instruments. Access the LabVIEW Help by selecting Help » Search the LabVIEW Help.
- **Getting Started with LabVIEW**—Use this document as a tutorial to familiarize yourself with the LabVIEW graphical programming environment and the basic LabVIEW features you use to build data acquisition and instrument control applications. Access the Getting Started with LabVIEW PDF by selecting Start » All Programs » National Instruments » LabVIEW » LabVIEW Manuals » LV\_Getting\_Started.pdf.
- **Getting Started with the LabVIEW Real-Time Module**—Use this document to learn how to develop a real-time project and VIs, from setting up RT targets to building, debugging, and deploying real-time applications. Access the Getting Started with the LabVIEW Real-Time Module PDF by selecting Start » All Programs » National Instruments » LabVIEW » LabVIEW Manuals » RT\_Getting\_Started.pdf.
- **CompactRIO Reference and Procedures (Scan Interface)**—Use this help file to learn about using the CompactRIO system in Scan Interface programming mode. To access this help file from LabVIEW, select Help » Search the LabVIEW Help, then expand Real-Time Module on the Contents tab and select CompactRIO Reference and Procedures (Scan Interface).
- **Example VIs**—To search for an example Functional Safety VI, select Help » Find Examples... in LabVIEW.

## Finding Known Issues

- **Functional Safety Editor**—For a list of known issues for the Functional Safety Editor, go to [ni.com/info](http://ni.com/info) and enter Info Code safetyissues.

- **C Series Functional Safety Module Firmware**—For a list of known issues for the firmware that installs on the C Series Functional Safety module, refer to the **Known Issues for Firmware Versions** section.
- **NI-RIO Device Drivers**—For a list of known issues and bug fixes for all NI-RIO Device Drivers versions, go to [ni.com/info](http://ni.com/info) and enter Info Code rioknownissues.
- **NI-RIO Device Drivers May 2017**—For a list of known issues for NI-RIO Device Drivers May 2017 release, go to [ni.com/info](http://ni.com/info) and enter Info Code rio2017knownissues.

#### Related concepts

- [C Series Functional Safety Systems](#)

## Updating Safety Software and Firmware

NI provides application updates, new features, and bug-fixes for software through the NI Update Service.

C Series Functional Safety modules ship with installed firmware that runs the User Program. Updates to this firmware will be distributed by NI as appropriate.

For information about receiving and managing updates, refer to the **NI Update Service Help**.



**Note** Visit [ni.com/critical-updates](http://ni.com/critical-updates) for information about available critical and security updates for NI software.

## C Series Functional Safety Firmware

### Firmware Release Versions

The following sections detail the C Series Functional Safety Firmware releases and associated known issues. You can read the firmware version through Scan Interface. To determine the firmware version, add a Property Node to your monitoring VI in LabVIEW.



**Caution** You must verify and formally document that your safety application is not affected by the known issues documented below.

Module	Version	Date Released	Notes
NI 9350	0x17081412	September 2017	This version shipped with the initial release of the NI 9350.
	0x18010811	March 2018	This version implements a fix for undetected faults when driving heavy loads.
NI 9351	0x18031516	May 2018	This version shipped with the initial release of the NI 9351.

Table 69. C Series Functional Safety Firmware Releases

Known Issue	Version Affected		
	0x17081412	0x18010811	0x18031516
Open circuit faults on digital outputs	✓	✓	
Passthrough value behavior	✓	✓	
Overcurrent on dual digital inputs with test pulses	✓	✓	✓
Undetected faults when driving heavy loads	✓		

Table 70. C Series Functional Safety Firmware Known Issues List

## Known Issues for Firmware Versions

### Open Circuit Faults on Digital Outputs

An open circuit fault will persist for the duration of the fault latch time when the User Program restarts as a result of changing operation modes.

### Passthrough Value Behavior

A channel driven true by passthrough from the monitoring VI in LabVIEW remains high after the module has been removed from the CompactRIO controller or if communication to the controller is lost.

## Overcurrent on Dual Digital Inputs with Test Pulses

In a dual input with test pulse configuration, an overcurrent condition on the odd-numbered channel causes both channels to de-energize. An overcurrent condition on an even-numbered channel only causes the even-numbered channel to de-energize.

## Undetected Faults When Driving Heavy Loads

In the following digital output configurations, the module will not generate test pulses, detect shorts to  $V_{sup}$ , or detect stuck high conditions.

- Single output with heavy output loading when the corresponding DI channel is unused or the corresponding DI channel is used and has a debounce filter of 0  $\mu$ s to 16,383  $\mu$ s or 2,125 ms to 5 s.
- Dual output with heavy output loading when the corresponding DI channel is unused or the corresponding DI channel is used and has a debounce filter of 0  $\mu$ s to 16,383  $\mu$ s or 2,125 ms to 5 s.
- Single output with external readback with heavy output loading and a debounce filter of 85  $\mu$ s to 16,383  $\mu$ s or 2,125 ms to 5 s.
- Single output with internal test pulse with heavy output loading when the corresponding DI channel is unused or the corresponding DI channel is used and has a debounce filter of 0  $\mu$ s to 16,383  $\mu$ s.
- Dual output with internal test pulse with heavy output loading when the corresponding DI channel is unused or the corresponding DI channel is used and has a debounce filter of 0  $\mu$ s to 16,383  $\mu$ s.

To avoid this condition, use one of the following methods:

- Use a debounce time between 16.5 ms and 2.047s.
- Verify that your application requires heavy output line loading. Refer to the **Output Line Load** section.
  - If your application does not require heavy output line loading, use a maximum of medium output line loading.

- If your application requires heavy output line loading, add a pull-down resistor to the output channel to reduce the output line load.

## NI Services

Visit [ni.com/support](https://ni.com/support) to find support resources including documentation, downloads, and troubleshooting and application development self-help such as tutorials and examples.

Visit [ni.com/services](https://ni.com/services) to learn about NI service offerings such as calibration options, repair, and replacement.

Visit [ni.com/register](https://ni.com/register) to register your NI product. Product registration facilitates technical support and ensures that you receive important information updates from NI.

NI corporate headquarters is located at 11500 N Mopac Expwy, Austin, TX, 78759-3504, USA.