

Evaluates: MAX16731

MAX16731 Evaluation Kit

General Description

The MAX16731 evaluation kit (EV kit) is a reference design platform designed for evaluation of the MAX16731, a single-output POL regulator with on-chip bias LDO, a single-output POL regulator with on-chip bias LDO that integrates full control circuitry and a power train that can provide up to 30A to the load. The EV kit package comprises a fully assembled and tested multilayer PCB implementation of high efficiency and high-power density solution.

The selection of key converter configuration parameters, acting on one external resistor and jumpers, allows design flexibility to match several application scenario requirements.

Refer to the MAX16731 IC data sheet for detailed information regarding the *Description, Features, Benefits, and Parameters*.

Features

- Wide 2.7V to 16V Input Voltage Range
- High Efficiency and Power Density
- 0.5V to 5.8V V_{OUT} (Selectable through Resistor Divider)
- Selectable: PWM Frequency, OCP Threshold, DEM Feature, DCM Mode, Voltage Loop Gain and Switching frequency (through jumpers)
- Low Component Count
- Proven PCB Layout
- Fully Assembled and Tested for Basic Functionality

[Ordering Information](#) appears at end of data sheet.

MAX16731 EV Kit Board Photos

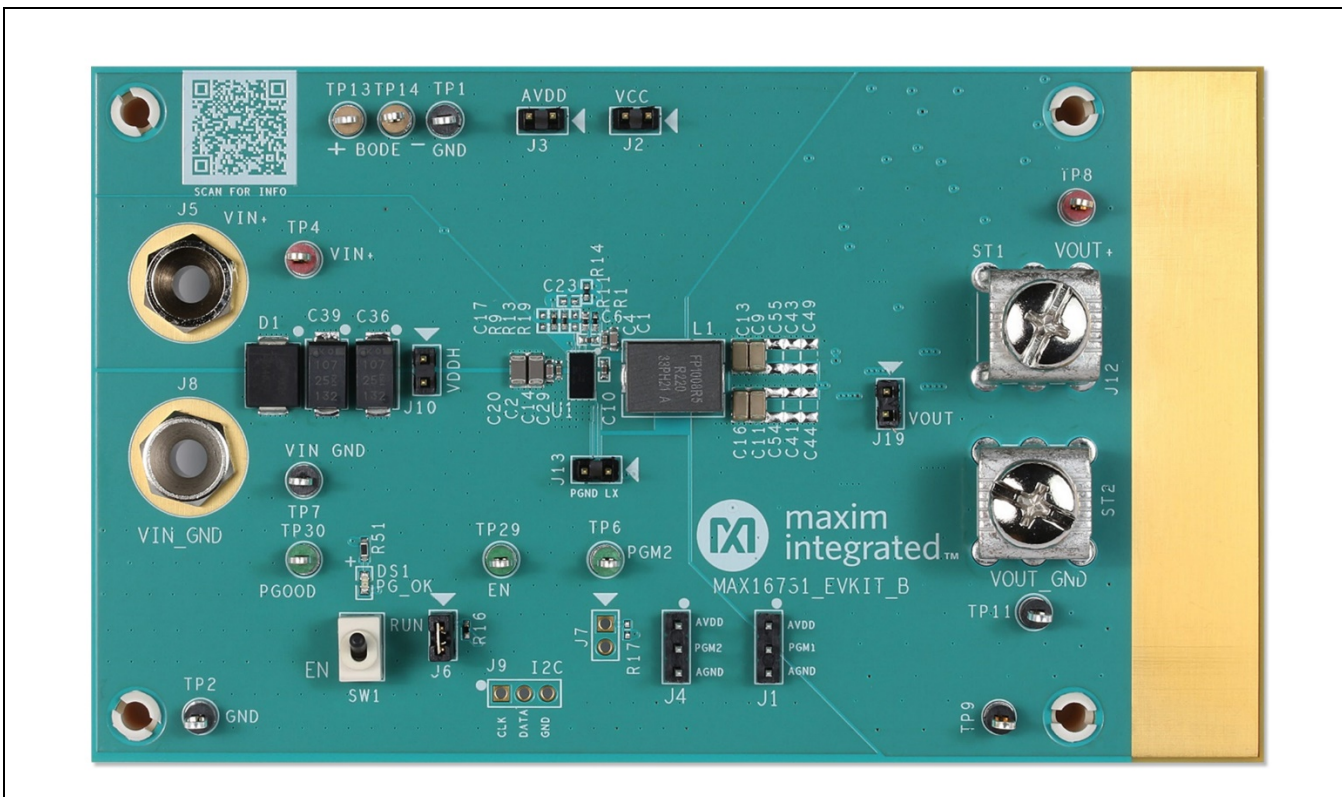

Figure 1. Top view of the MAX16731 EV kit

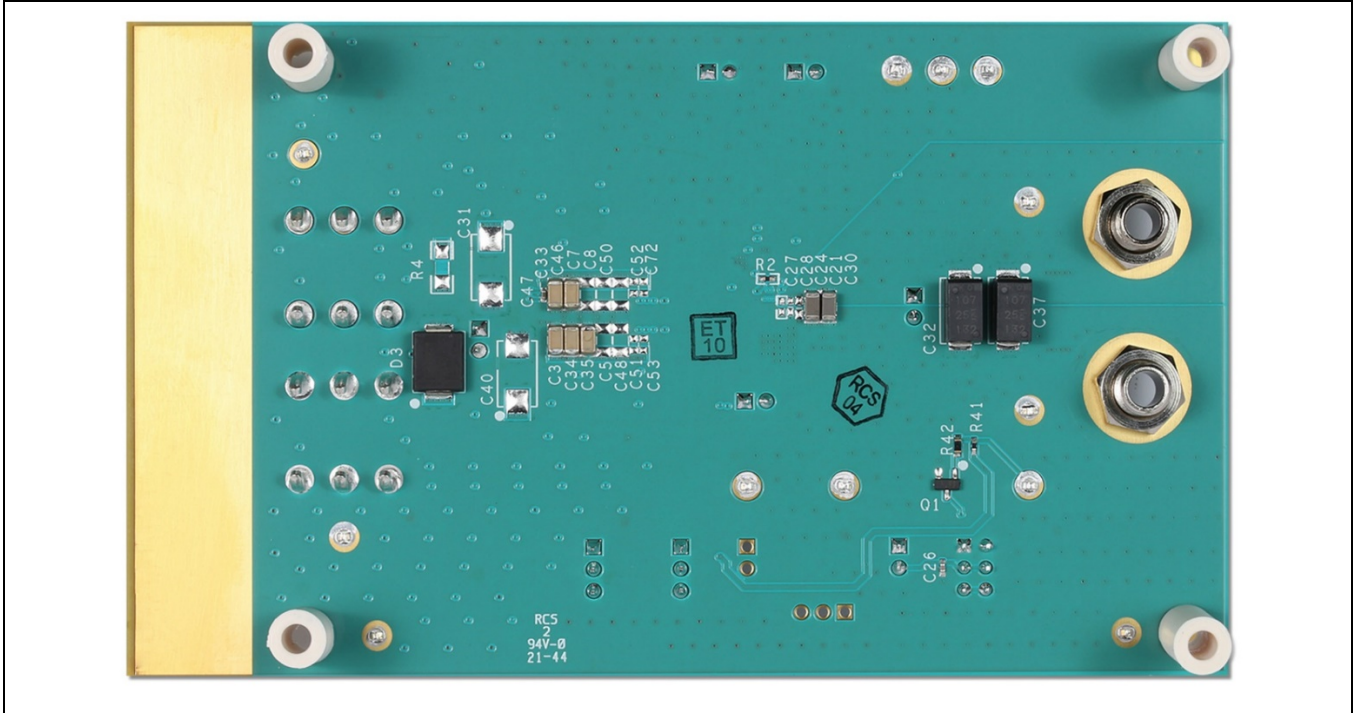

Figure 2. Bottom view of the MAX16731 EV kit

Quick Start

Required Equipment

- MAX16731 EV kit and EV kit datasheet
- 2.7V to 16V V_{IN} power supply (10A minimum current capability)
- Measure instruments E.g. Digital Voltage and Current meters
- Multi-trace digital scope (not mandatory)
- Low voltage 30A Electronic load

Procedure

The EV kit is fully assembled and tested. Make the required hardware connections to the start operation of the EV kit.

Note: Do not supply V_{IN} until the board has been correctly configured and with input and output cables connected.

Follow the steps to verify basic board operations and to run the EV kit.

1. Setup V_{IN} powers supply at a voltage level between 2.7V and 16V. Disable the power supply output.
Connect the positive and negative terminal of the V_{IN} power supply to the board using suitable section cables and equipped with male banana plugs. (J5 + V_{IN} , J8 GND).
2. Verify that the position of each jumper on the board is correct according to the Configuration that needs to be tested (See [Table 1](#) for Jumpers and Rprog options).
3. Connect the electronic load to the output screw connectors, respecting the polarity (if you want to test the regulator behavior under load). Disable the load. (ST1, + V_{OUT} , ST2 GND).
4. Connect all the measurement instruments or scope probes to the targeted test points to measure current or voltage, or to observe operating waveforms (See [MAX16731 EV Kit Schematic Diagram](#)).
5. Supply V_{IN} .
6. Enable the regulator through the EN switch SW1 (PWM starts).
7. Enable your load.

Note: Steps 5-7 are not subjected to sequence limitations.

Detailed Description of Hardware

Operation

The MAX16731 IC is a monolithic, single-output, high-frequency, step-down converter with internal bias LDO, optimized for applications requiring high-power density and high-efficiency. Detailed product and application information is provided in the MAX16731 IC datasheet.

Output Enable (OE)

OE pin is used to enable/disable the operation and so the output voltage. On the EV kit board, the selection switch SW1 is present to allow enabling and disabling the regulator.

Output Voltage selection

The MAX16731 has an internal 0.5V reference voltage. The MAX16731, 30A, integrated step-down switching regulator performs a differential V_{OUT} voltage sense to improve regulation at high load current. When the desired output voltage is higher than 0.5V, it is required to use a resistor divider R_{13} and R_9 to sense the output voltage. (See [MAX16731 EV Kit Schematic Diagram](#)).

The resistor divider ratio is given by Equation 1.

Equation 1:

$$V_{OUT} = V_{REF} \times \left(1 + \frac{R_{13}}{R_9}\right)$$

where:

V_{OUT} = Output voltage

V_{REF} = 0.5V fixed reference voltage

R_{13} = Top divider resistor

R_9 = Bottom divider resistor

Note: It is recommended for R_9 , not to exceed 5K Ω .

Test points

J2 and J3 headers, respectively VCC and AVDD are intended as test points to measure the two bias voltages. VCC is provided by the on-chip LDO, AVDD (power IC internal analog blocks supply) is derived from VCC through a simple RC filter. J10 and J13 are respectively VDDH and LX test points that can be used for waveforms measurements. J2, J3, J10, and J13 must be left open if not connected to any external measurement instrument. TP13, TP14, TP1 are three test points dedicated for Bode plot acquisition. A 10 Ω resistor is in series into the feedback line and provides an input port to inject the sweep frequency signal generated by a Bode plot equipment, through a decoupling transformer.

User case selection

The MAX16731 gives the flexibility to set application parameters acting on the value of one resistor (R_2 , connected on PGM0 pin) and the logic level of PGM1 and PGM2 at the power-up. See [Table 2](#) for setting the value of the resistor on PGM0, a 32-level code reading capability allows selecting both the switching frequency of the converter and the voltage control loop gain, selecting through six scenario configurations (A, B, C, D, E, and F) see [Table 4](#).

PGM1 and PGM2 can recognize only a three-level setting, instead (AVDD, AGND, Hi-impedance). See [Table 3](#) to set the position of J1 and J4, allowing to select of the wanted OCP (over current protection) threshold level and the option to allow the converter to work into auto DCM (Discontinuous Current Mode) at light load.

Note: PGM0 resistor, PGM1, and PGM2 logic level are detected only one time at the power-on reset. Moving the jumpers while the bias is present won't affect any of the parameters.

Table 1. Jumpers and Rprog options

JUMPERS/Rprog	POSSIBLE CONNECTION/VALUE	FEATURE
J1	Open, (Short 1-2), (Short 2,3)	OCP levels and DCM options
J2	Open, (Short 1-2), (Short 2,3)	OCP levels and DCM options
R2	95.3 Ω to 115.000 Ω	f_{SW} and scenario settings

Note: See [Table 2](#), [Table 3](#), and [Table 4](#) for more details.

PGM0 Factory settings

The MAX16731 EV kit comes pre-assembled as follows:

- R2 on PGM0, 95.3Ω. ($f_{sw} = 500\text{KHz}$, Scenario A selected. See [Table 4](#) for Scenario Details)

The value of R2 selects the switching frequency and one of the six scenarios (A, B, C, D, E, F)

Table 2. PGM0 codes selection

PGM0 CODES	R(Ω)	f_{sw} (kHz)	Scenario
0	95.3	500	A
1	200		B
2	309		C
3	422		D
4	536		E
5	649		F
6	768	600	A
7	909		B
8	1050		C
9	1210		D
10	1400		E
11	1620		F
12	1870	750	A
13	2150		B
14	2490		C
15	2870		D
16	3740		E
17	8060		F
18	12400	1000	A
19	16900		B
20	21500		C
21	26100		D
22	30900		E
23	36500		F
24	42200	1200	A
25	48700		B
26	56200		C
27	64900		D
28	75000		E
29	86600		F
30	100000	1500	A
31	115000		B

PGM1 and PGM2 settings

PGM1 and PGM2 are two selection pins tri state sensitive. These pins can be connected to VCC, GND or left open acting respectively on the jumpers named as J1 and J4. [Table 3](#) shows the selection of DCM mode and OCP level (over current protection level) according to the position of J1 and J4.

Table 3. PGM1 and PGM2 selection

PGM1 CONNECTION	PGM2 CONNECTION	DCM	OCP (A)	PGM 1 AND 2 CODE
OPEN	OPEN	Disable	38	0
	AGND	Enable		1
	AVDD	Disable	28	2
AGND	OPEN	Enable	38	3
	AGND	Disable		4
	AVDD	Enable		5
AVDD	OPEN	Disable	28	6
	AGND	Enable		7
	AVDD	Disable	33	8

See [Table 4](#) for the R_{VGA} value, that fix the gain in the con voltage control loop, according to the selected scenario.

The value of the voltage control loop gain can be calculated as:

$$V_{GAIN} = \left(\frac{R_{VGA}}{10K\Omega} \right)$$

So, it can assume values from 1.57 to 6.23.

Table 4. Voltage loop gain and DEM status according to the scenario selection

SCENARIO	R_{VGA} (K Ω)	DEM STATUS
A	15.7	Enabled
B	22.7	Enabled
C	31.3	Enabled
D	44.8	Disabled
E	52.9	Disabled
F	62.3	Disabled

The voltage loop gain resistance affects the bandwidth of the voltage loop. For good stability and transient response, the equivalent voltage loop bandwidth is recommended to be set lower than 1/5th of the switching frequency.

Refer to the MAX16731 IC datasheet for detailed calculation of the bandwidth, function of voltage feedback resistor divider ratio, and amount of output capacitance.

MAX16731 EV Kit Performances Chart (TOC)

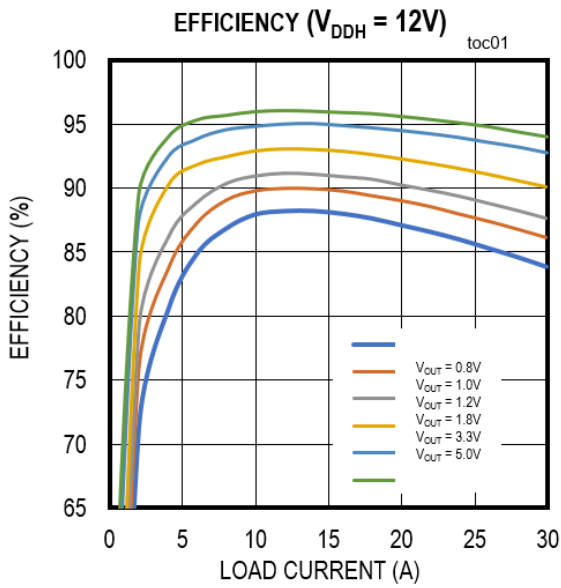

Efficiency curves

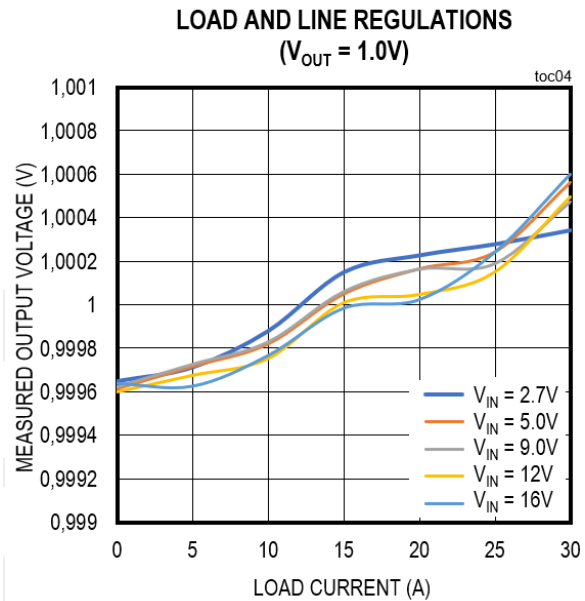

Load line regulation

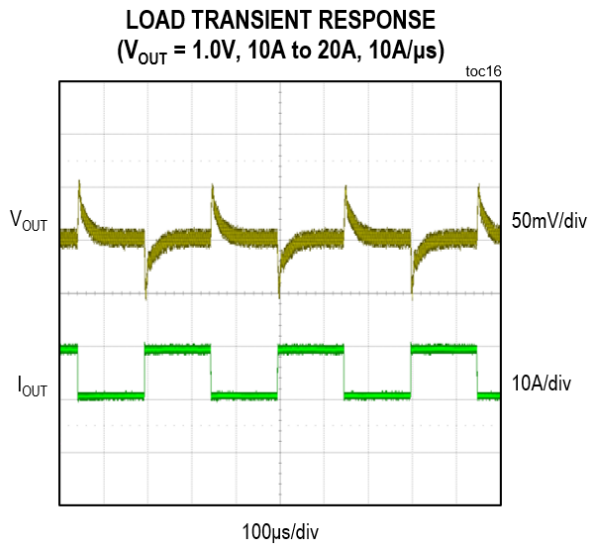

Load transient response

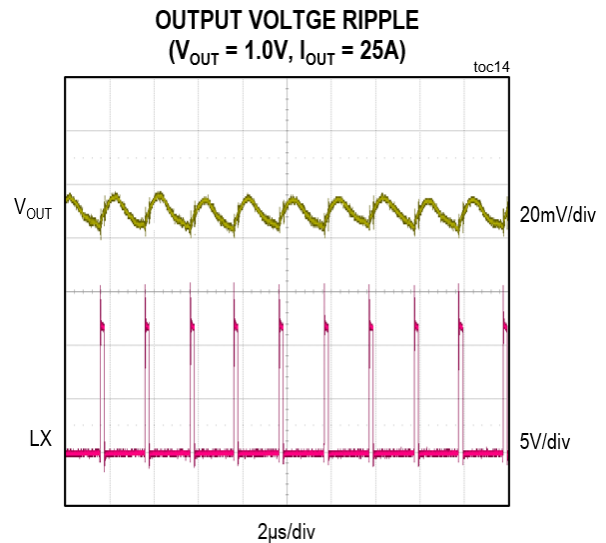

Output voltage ripple at 25A

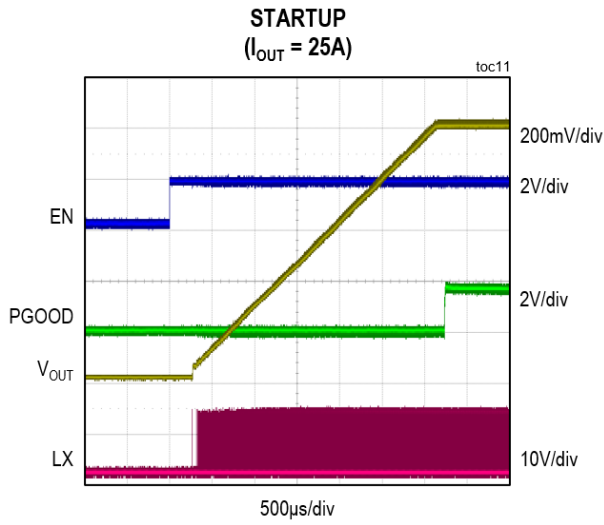

Soft start

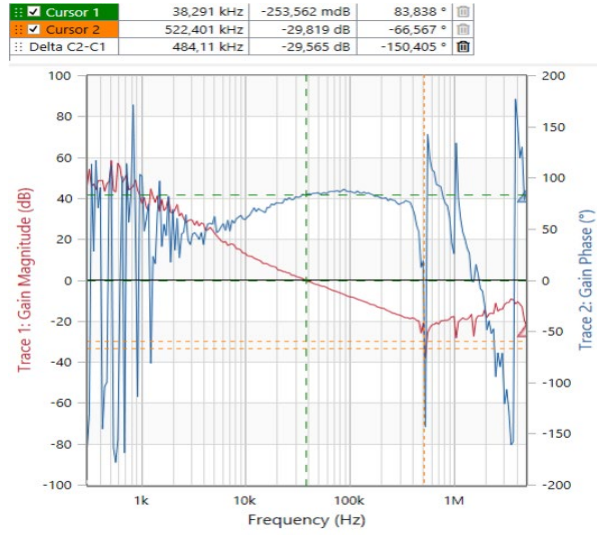

Bode Plot

Ordering Information

PART	TYPE
MAX16731EVKIT#	EV Kit

#Denotes RoHS compliance.

MAX16731 EV Kit Bill of Materials

REF DES	QTY	MFG PART#	MANUFACTURER	VALUE	DESCRIPTION
C1	1	GMC10X7R475K6R3NT, CL10B475KQ8NQN, JMK107BB7475KA,	SAMSUNG, TAIYO YUDEN, CAL- CHIP	4,7uF/6,3v	CERAMIC CAP, SMT(0603)
C2, C20, C21, C30	4	CL31X226KAHN3N, GRM31CC81E226KE11	SAMSUNG, MURATA	22uF/25v	CERAMIC CAP, SMT(1206)
C3, C9, C11, C13, C16, C33-C35, C46	9	GRM31CD80J107ME39	MURATA	100uF/6,3v	CERAMIC CAP, SMT(1206)
C4	1	GRM155R70J104KA01	MURATA	0,1uF/6,3v	CERAMIC CAP, SMT(1206)
C6	1	CL05B105KQ5NQN, GRM155R70J105KA12	SAMSUNG, MURATA	1uF/6,3v	CERAMIC CAP, SMT(0402)
C10	1	LMK105B7474KV, GRM155R71A474KE01	TAIYO YUDEN, MURATA	0,47uF/10v	CERAMIC CAP, SMT(0402)
C14	1	TMK107B7105KA, C1608X7R1E105K080AE	TAIYO YUDEN, TDK	1uF/25v	CERAMIC CAP, SMT(0603)
C26	1	C0402C102K5GAC	KEMET	1000pF	CERAMIC CAP, SMT(0603)
C29, C47	2	GRM155R71E104KE14, C1005X7R1E104K050BB, TMK105B7104KVH	MURATA, TDK, TAIYO YUDEN	0,1uF/25v	CERAMIC CAP, SMT(0402)
C32, C36, C37, C39	4	T521X107M025ATE060	KEMET	100uF/25v	TANTALUM, SMT(7343)
D1, D3	2	MBRS540T3G	ON-SEMICONDUCTOR	—	SCHOTTKY DIODE
DS1	1	LGL29K-G2J1-24-Z	OSRAM	—	GREEN LED
J1, J4	2	PEC03SAAN	SULLINS CONNECTOR	3 PIN	MALE THROUGHT HOLE CONN.
J2, J3, J6, J10, J13, J19	6	TSW-101-22-L-D	SAMTEC	2 PIN	MALE THROUGHT HOLE HEADER
J5, J8	2	6095	KEISTONE	1 PIN	PANELMOUNT FEMALE
L1	1	FP1008R5-R220-R	EATON	220nH	FERRITE INDUCTOR
Q1	1	BSS138	ONSEMI	—	LOGIC LEVEL NMOS
R1	1	CRCW04024R70FK	VISHAY DALE	4,7ohm	RESISTOR SMT(0402)
R2	1	CRCW040295R3FK	VISHAY DALE	95,3ohm	RESISTOR SMT(0402)
R9, R13, R16	3	CRCW04023K00FK	VISHAY DALE	3Kohm	RESISTOR SMT(0402)
R11	1	RC0402JR-070RL	YAGEO	0ohm	RESISTOR SMT(0402)
R14	1	9C04021A10R0FL	YAGEO	10ohm	RESISTOR SMT(0402)
R41	1	CRCW040220K0FK	VISHAY DALE	20Kohm	RESISTOR SMT(0402)
R42	1	RC0603FR-07100RL	YAGEO	100ohm	RESISTOR SMT(0603)
R51	1	ERJ-3EKF2100	PANASONIC	210ohm	RESISTOR SMT(0603)

ST1, ST2	2	7808	KEYSTONE	—	SCREW TERMINAL
SW1	1	GT21MCBE	C&K COMPONENTS	—	THROUGH HOLE SWITCH
TP1, TP2, TP7, TP9, TP11	5	5011	KEYSTONE	—	TEST POINT
TP6, TP29, TP30	3	5010	KEYSTONE	—	TEST POINT
TP13, TP14	2	5012	KEYSTONE	—	TEST POINT
U1	1	MAX16731AVX+	ANALOG DEVICE	—	POL REGULATOR (WLP45)
C5, C7, C8, C48, C50, C54, C55	DNP	GRM31CD80J107ME39	MURATA	100uF/6,3v	CERAMIC CAP, SMT(1206)
C17	DNP	VJ0402A101FXJCW1BC	VISHAY	100pF	CERAMIC CAP, SMT(0402)
C23	DNP	C0402C103J3RAC	KEMET	0,01uF/25v	CERAMIC CAP, SMT(0402)
C24	DNP	TMK107B7105KA, C1608X7R1E105K080AE	TAIYO YUDEN, TDK	1uF/25v	CERAMIC CAP, SMT(0603)
C27, C28	DNP	GRM155R71E472KA01	MURATA	4700pF/25v	CERAMIC CAP, SMT(0402)
C31, C40	DNP	T491X477K010AT	KEMET	470uF/10v	TANTALUM, SMT(7343)
C41, C43, C44, C49	DNP	T491X477K010AT			
C51, C53, C72	DNP	CL31X476KQHNNN	SAMSUNG	47uF/6,3v	CERAMIC CAP, SMT(1206)
J7	DNP	TSW-101-22-L-D	SAMTEC	2 PIN	MALE THROUGH HOLE HEADER
J9	DNP	PEC03SAAN	SULLINS	3 PIN	MALE THROUGH HOLE HEADER
R4	DNP	ERJ-P08J101	PANASONIC	10ohm	RESISTOR SMT(1206)
R17	DNP	CRCW04023K00FK	VISHAY	3Kohm	RESISTOR SMT(0402)
R19	DNP	RC0402JR-070RL	YAGEO	0ohm	RESISTOR SMT(0402)

MAX16731 EV Kit Schematic Diagram

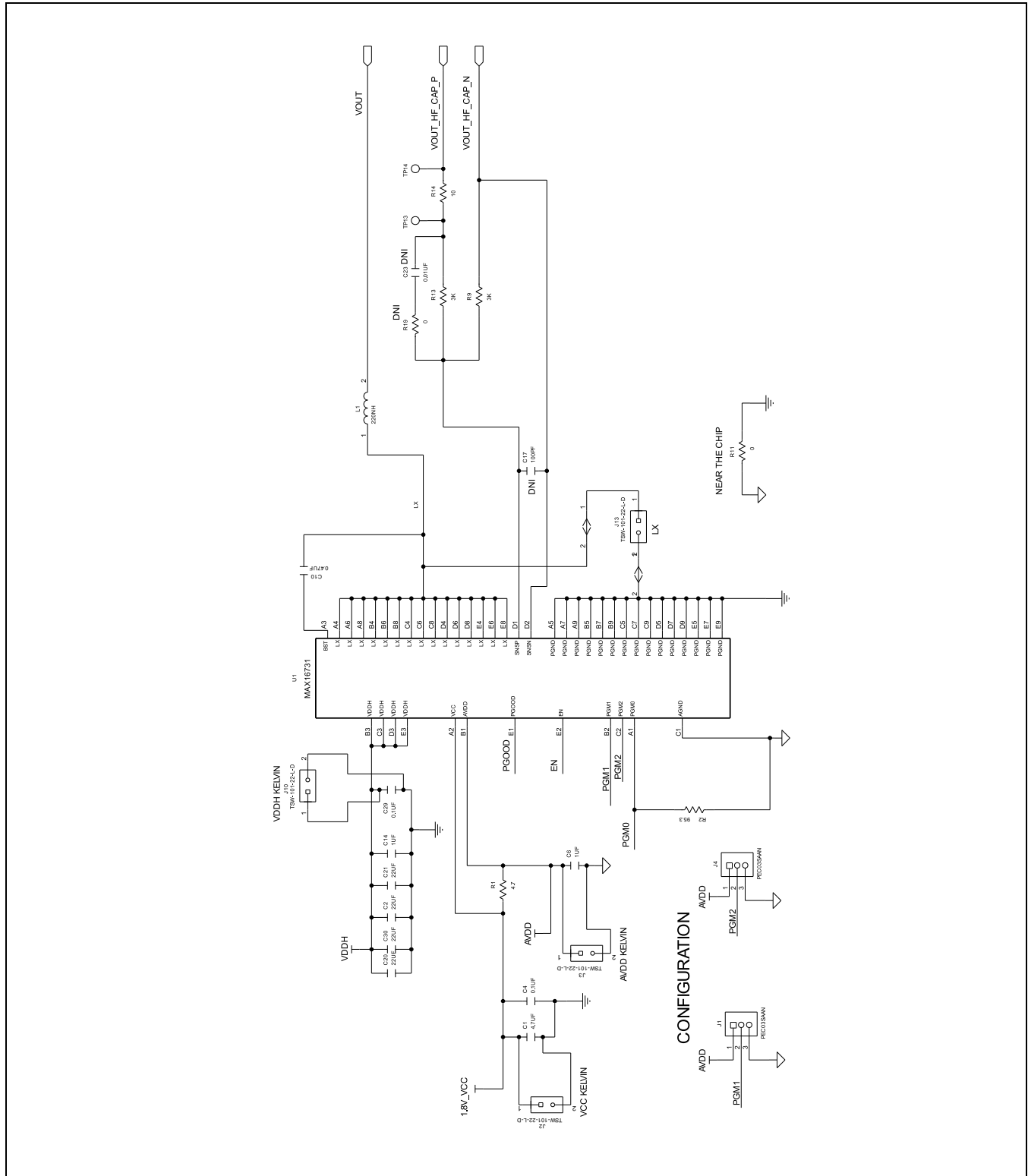

MAX16731 EV Kit Schematic Diagram (Input/Output Caps)

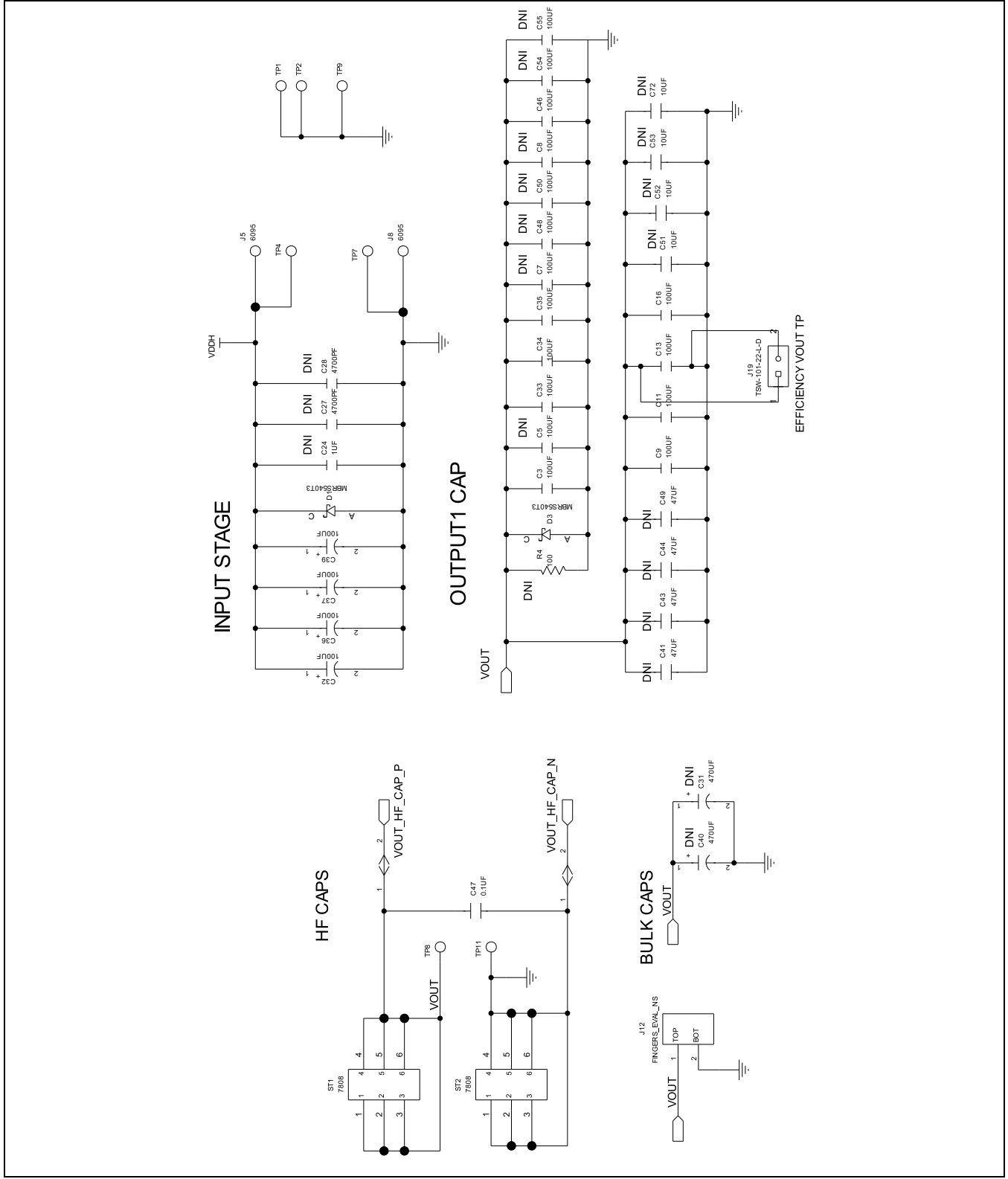

MAX16731 EV Kit Schematic (EN switch, PGOOD indicator)

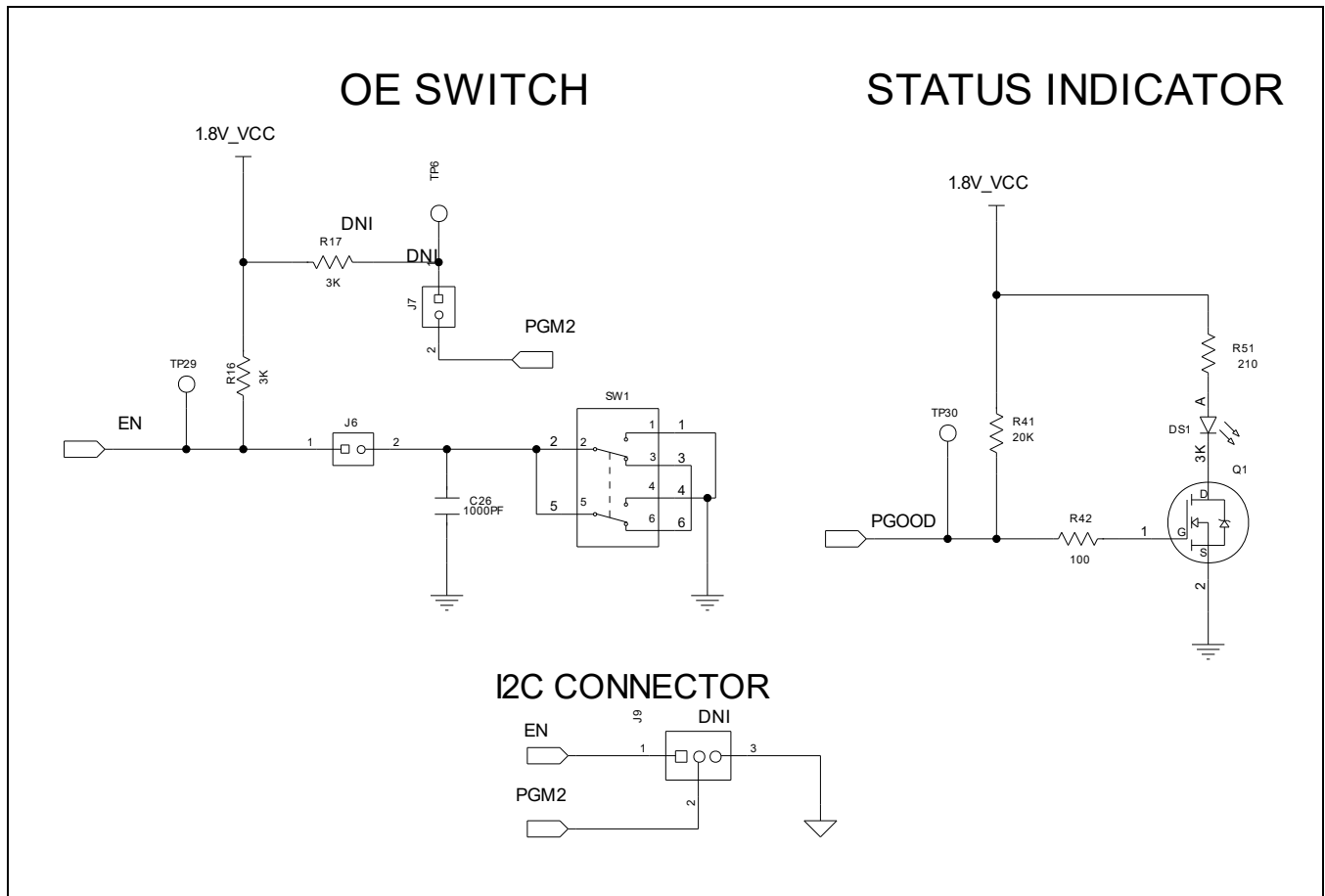

MAX16731 EV Kit PCB Layout Diagrams

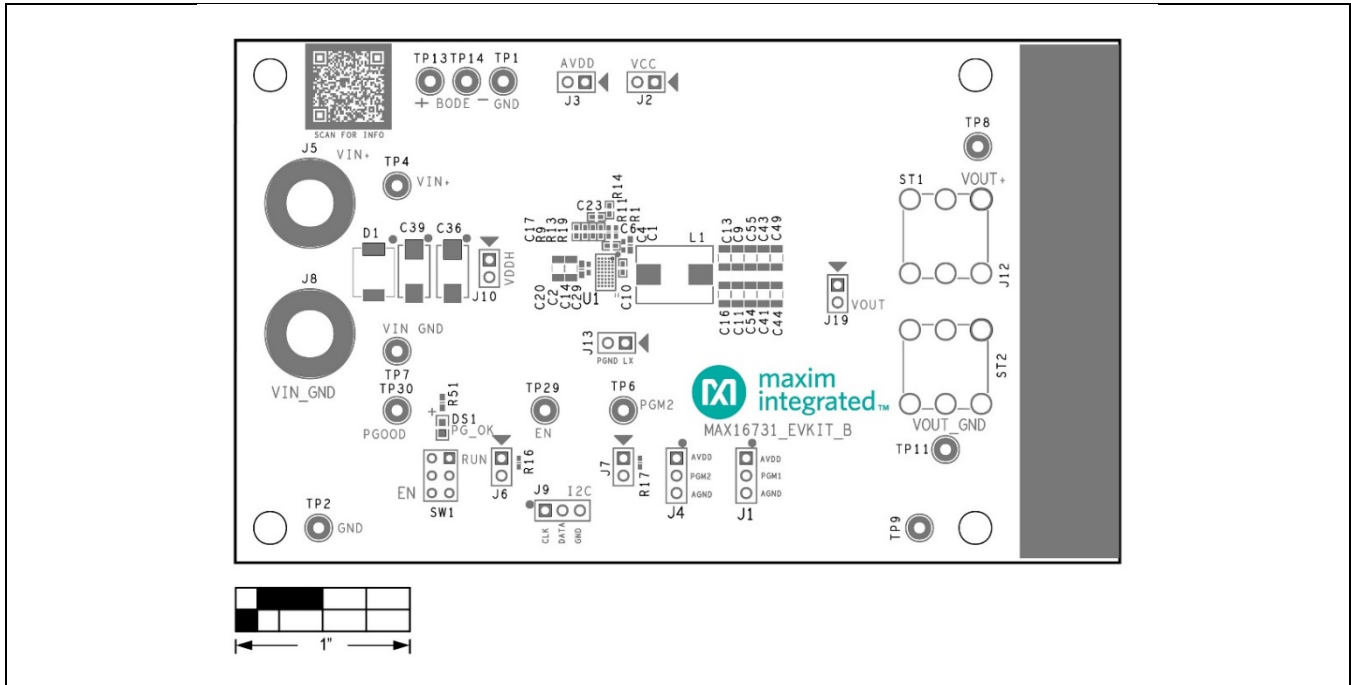

MAX16731 EV kit Component Placement Guide—Top Silkscreen

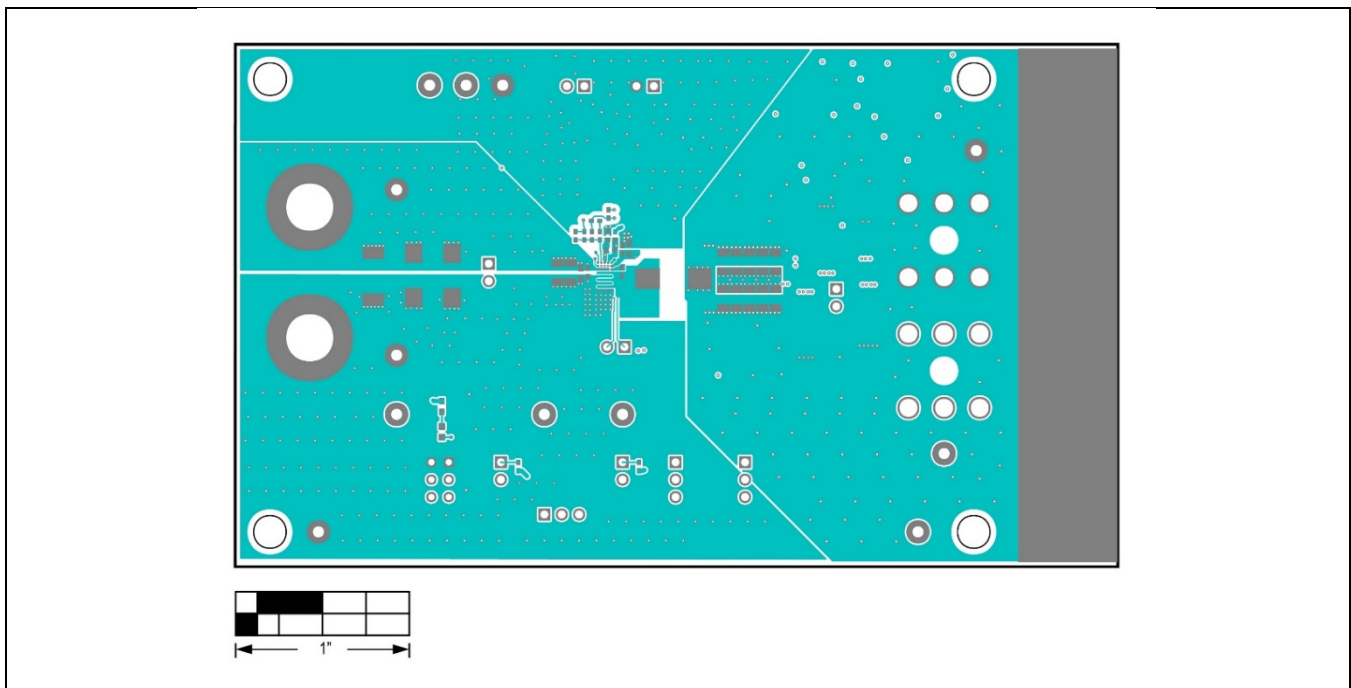

MAX16731 EV kit PCB Layout—Top View

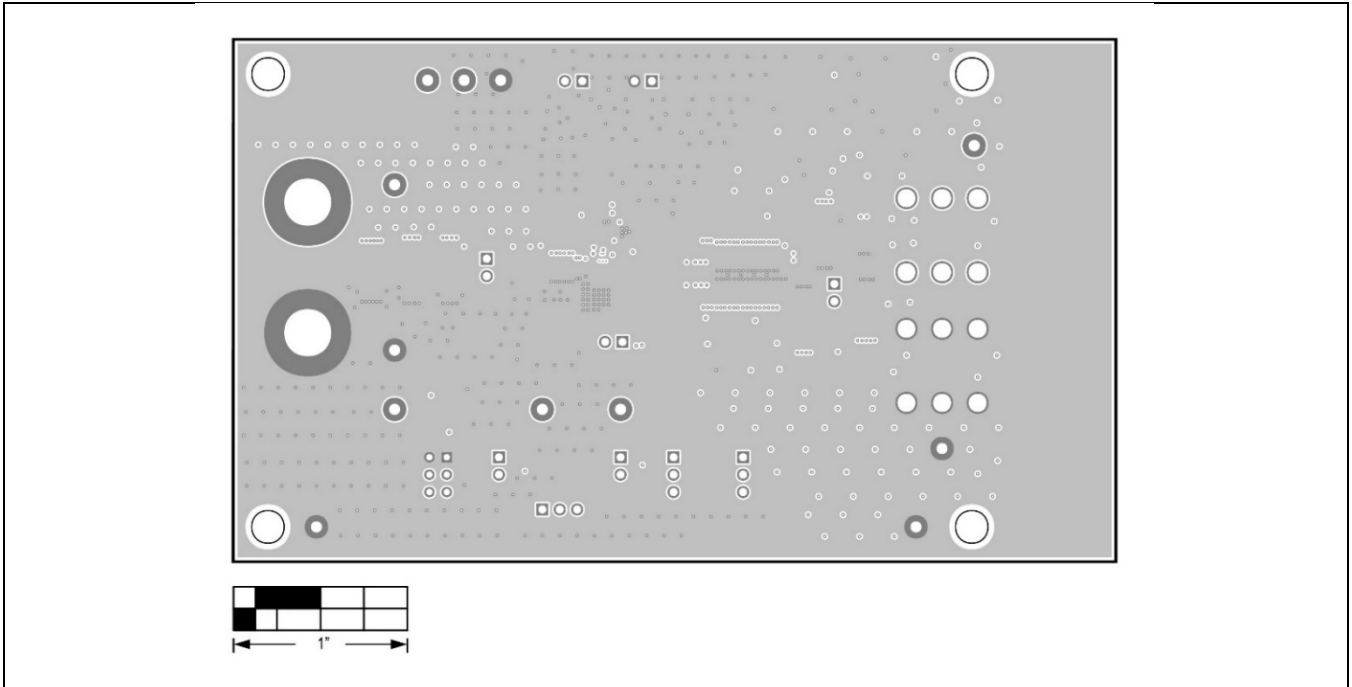

MAX16731 EV Kit PCB Layout—Layer 2

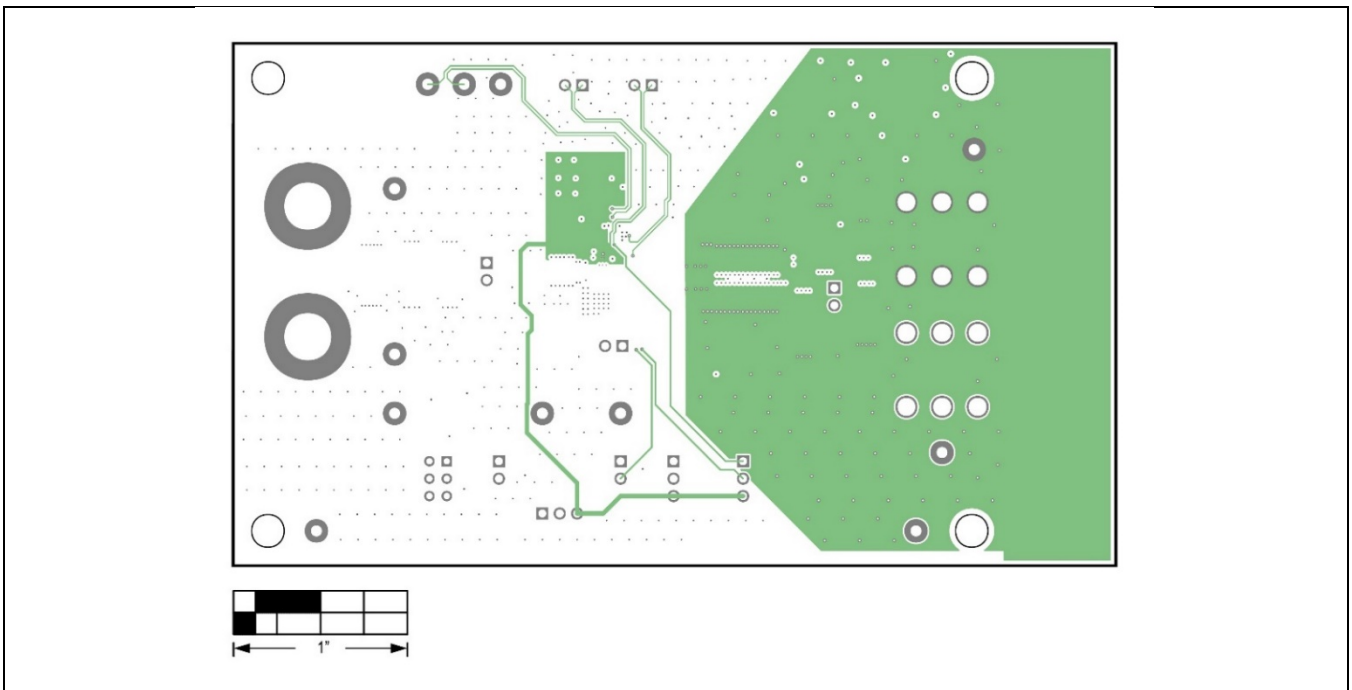

MAX16731 EV Kit PCB Layout—Layer 3

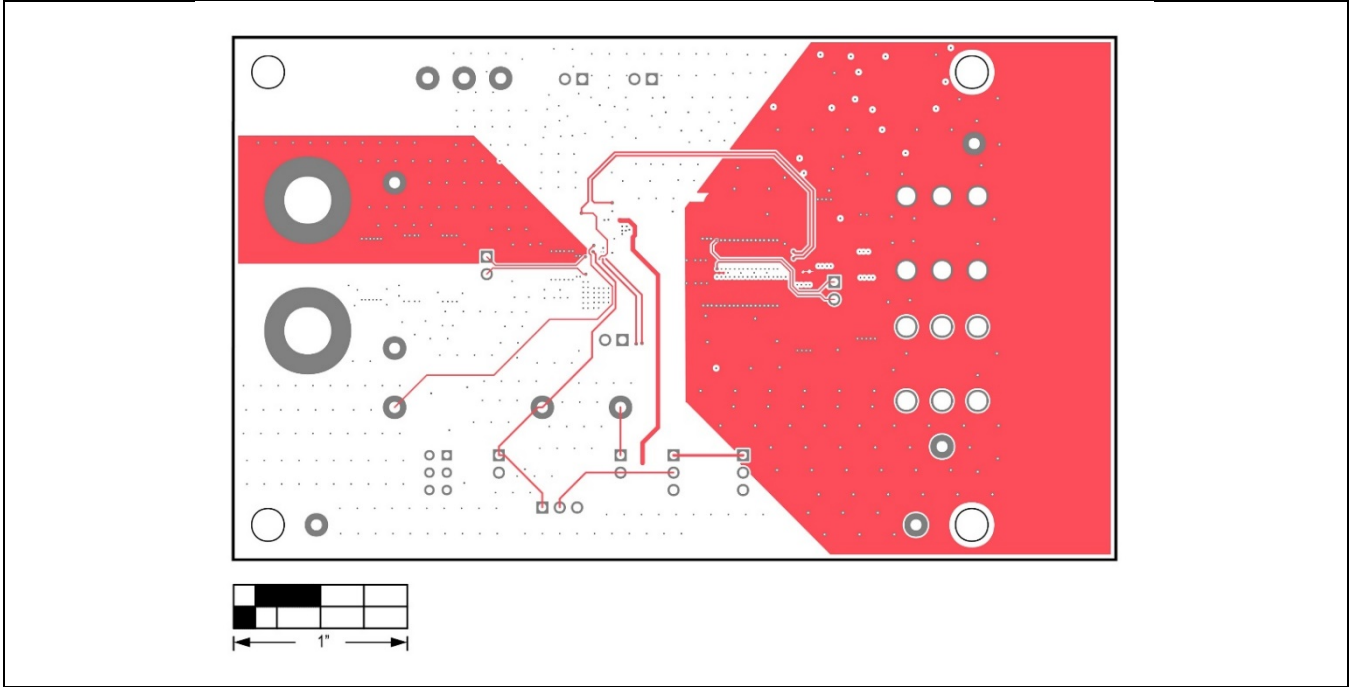

MAX16731 EV Kit PCB Layout—Layer 4

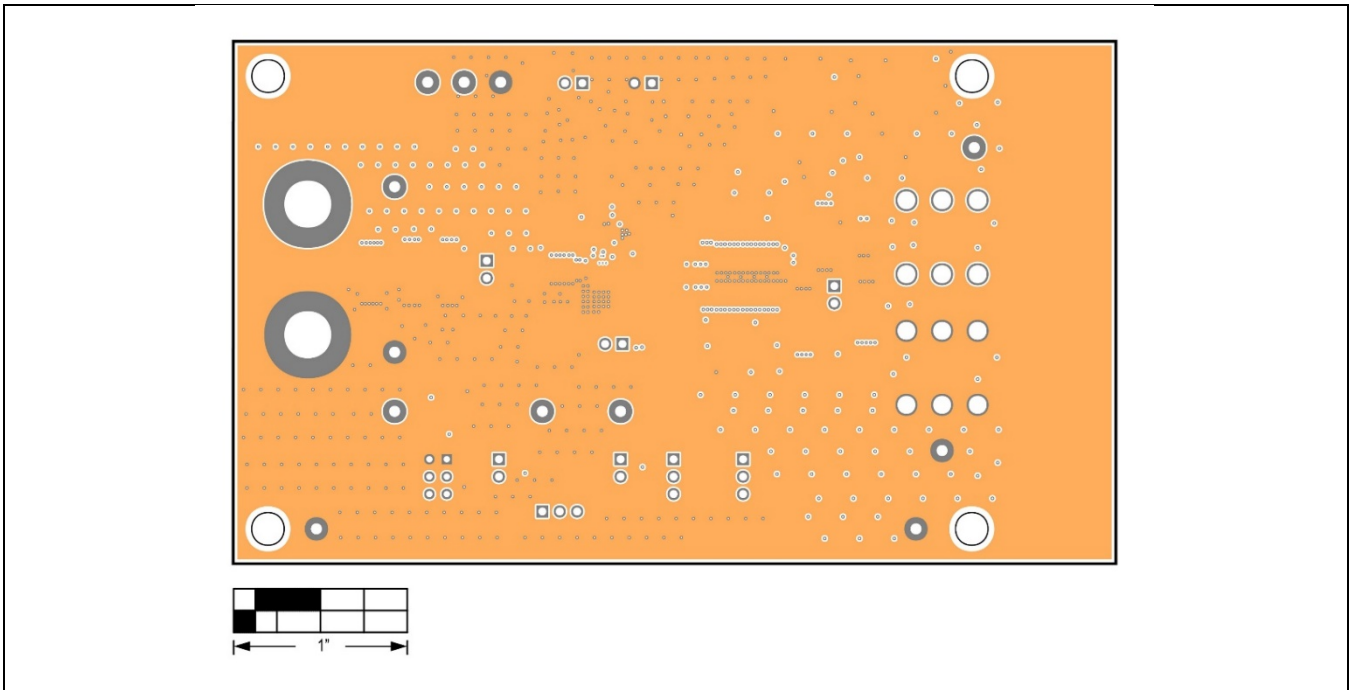

MAX16731 EV Kit PCB Layout—Layer 5

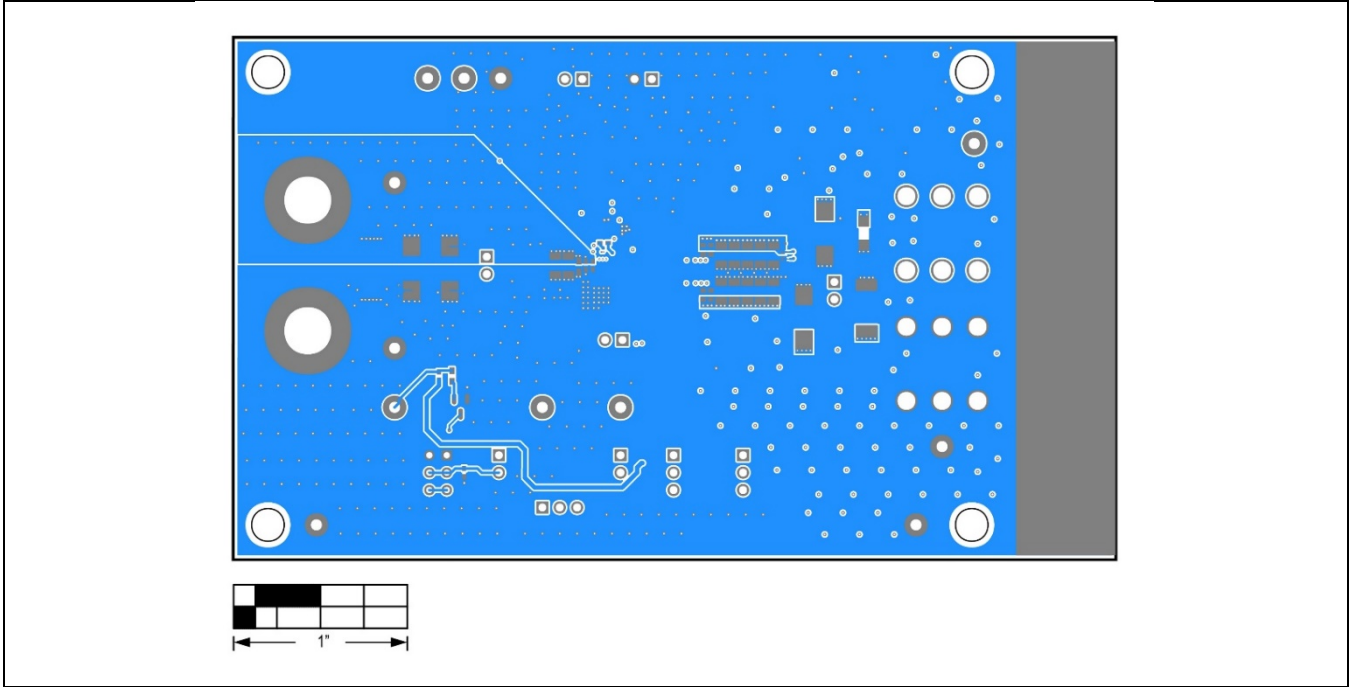

MAX16731 EV Kit PCB Layout—Bottom View

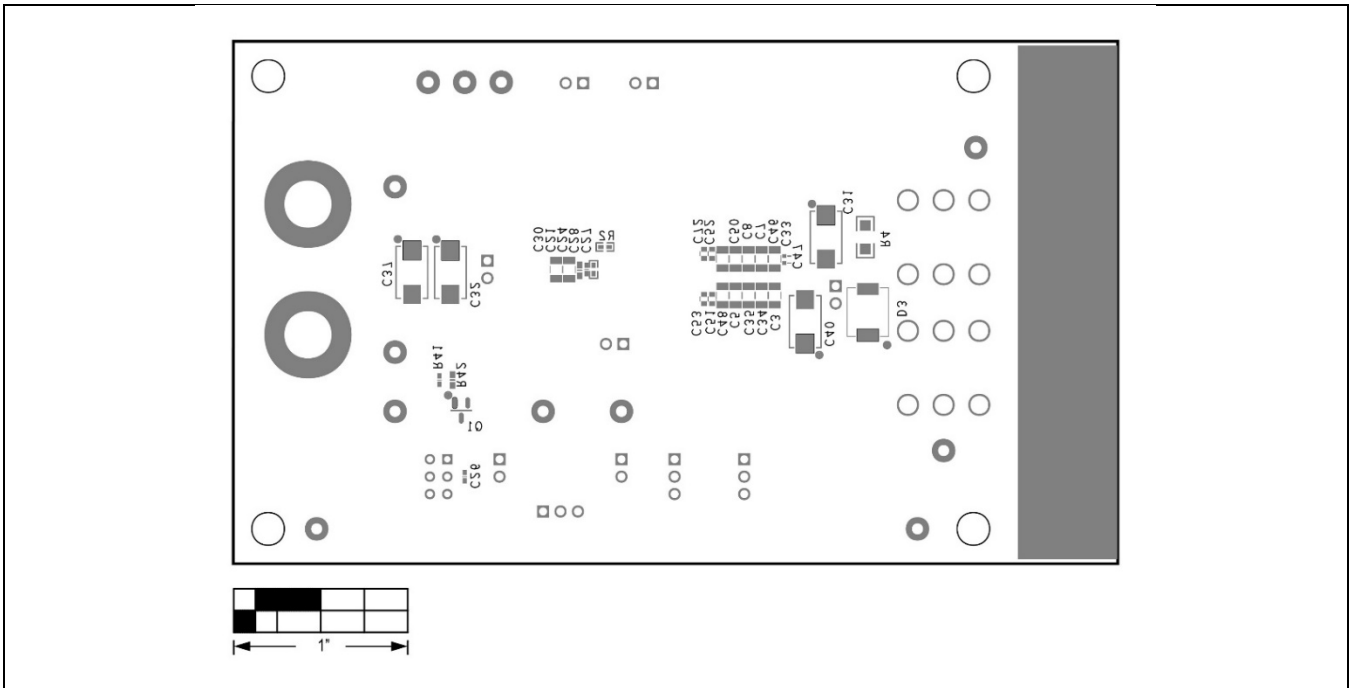

MAX16731 EV kit Component Placement Guide—Silkscreen Bottom

Revision History

REVISION NUMBER	REVISION DATE	DESCRIPTION	PAGES CHANGED
0	04/22	Initial release	—

