

## Digital Output Gage Pressure Sensor

## MMR902 Data Sheet

### DESCRIPTION

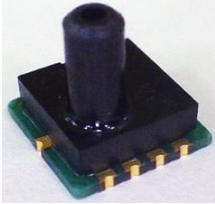

This product is digitally outputs a pressure value which was corrected in the module. Customers need no correction because it corrects and outputs the differences of sensors and temperature characteristics. It does not require complicated sensor drive or control circuit, and devices with high performance can be made only with this module and an external microcontroller which will be the host.

### FEATURES

- Small package: 7.0(W) ×7.0(D) ×7.2(H)mm  
Operating pressure range: -30~360mmHg (-4~47.99kPa)  
Pressure resolution: 0.001mmHg (0.13Pa)  
effective resolution: 0.020mmHgRMS (2.7PaRMS) (at MODE1)  
Pressure measurement error: ±2mmHg (±266Pa)
- It corrects the differences of sensors and temperature characteristics when shipped from our factory.
- It digitally outputs pressure value corrected in the module. (SPI/I2C)  
I2C slave address (7 bits) is 0x65.

## INDEX

DESCRIPTION .....	1
FEATURES .....	1
BLOCK DIAGRAM.....	3
PIN CONFIGURATION.....	4
TERMINAL EXPLANATIONS .....	5
ABSOLUTE MAXIMUM RATINGS .....	6
RECOMMENDED OPERATING CONDITIONS .....	6
ELECTRICAL CHARACTERISTICS .....	7
Analog characteristics .....	7
Digital I/O.....	8
Pressure sensor characteristics.....	9
Temperature sensor characteristics .....	9
Definition of characteristics .....	10
FUNCTION EXPLANATION.....	12
Function Outline.....	12
Flow chart of pressure/temperature measurement.....	13
Product code.....	14
SERIAL COMMUNICATION INTERFACE .....	14
Baud rate.....	15
SPI format .....	16
SPI AC Characteristics.....	18
I2C format .....	19
I2C AC Characteristics .....	22
Command code .....	23
State transition table .....	26
Timing Chart.....	27
TYPICAL APPLICATION CIRCUIT .....	28
TYPICAL PERFORMANCE CHARACTERISTICS .....	29
DIMENSIONS .....	34
PRODUCT NAME.....	35
PRODUCT LINEUP .....	35
PRESSURE SENSOR LINEUP .....	36
NOTES.....	37
Safety Precautions.....	37
Application considerations during actual circuit design .....	38
Precautions for Foreign Exchange and Foreign Trade Control Act .....	38
Prohibitions for Industrial Property Rights .....	38
Precautions for Product Liability Act.....	38
Others .....	38
ATTENTION .....	39
ADDDITIONAL NOTES.....	39
MARKING CONTENTS .....	40
PACKING SPECIFICATIONS (TRAY) .....	41
QUANTITY .....	41
PACKING SPECIFICATIONS.....	41
PACKING SPECIFICATIONS (TAPING, B HOUSING, R HOUSING) .....	46
QUANTITY .....	46
PACKING SPECIFICATIONS.....	46
RECOMMENDED LAND PATTERN .....	54
CONDITION FOR PACKAGE MOUNTING.....	55
Pb-Free recommended profile condition .....	55
Storage method .....	56

BLOCK DIAGRAM

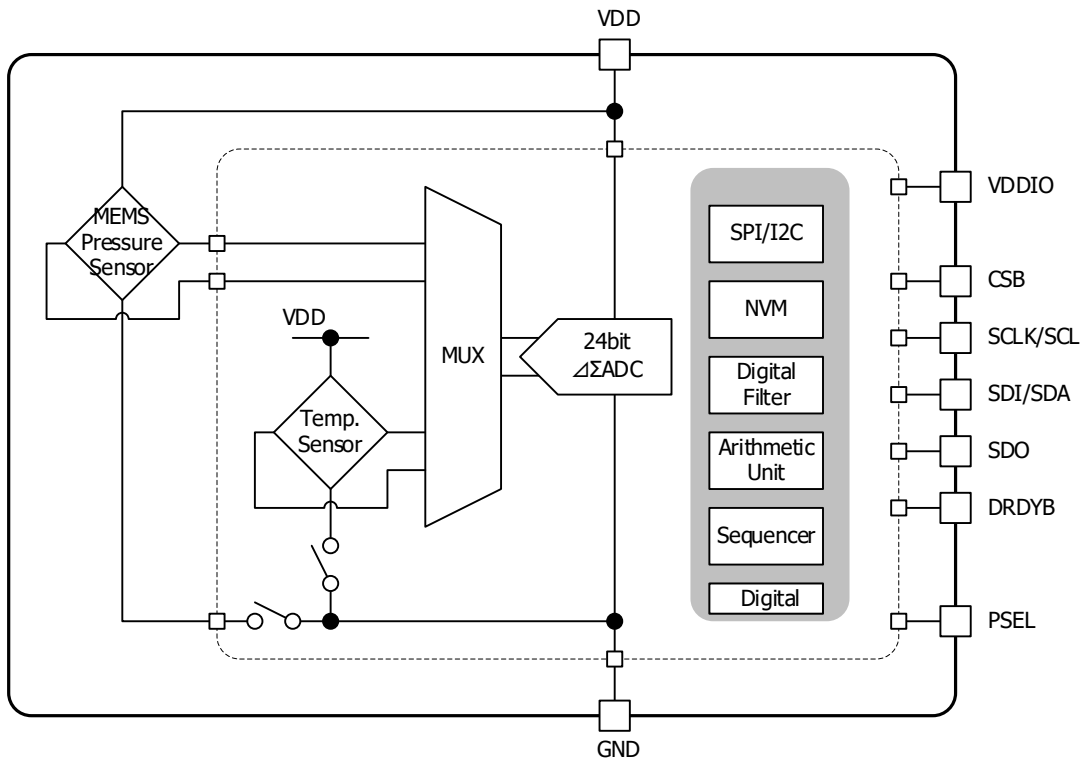

Fig.1 Block diagram

PIN CONFIGURATION

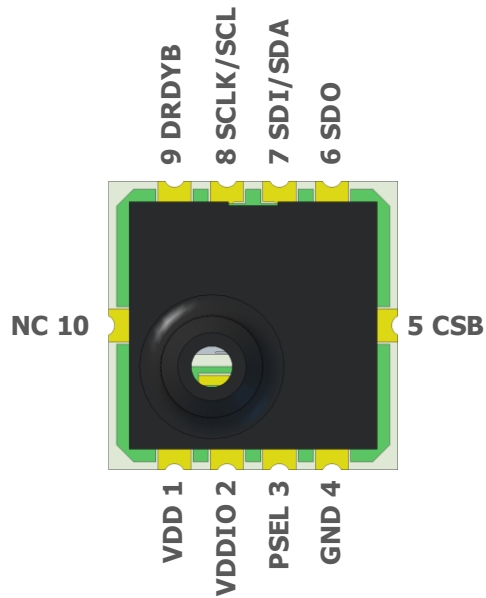

Fig. 2 Pin configuration (Top view)

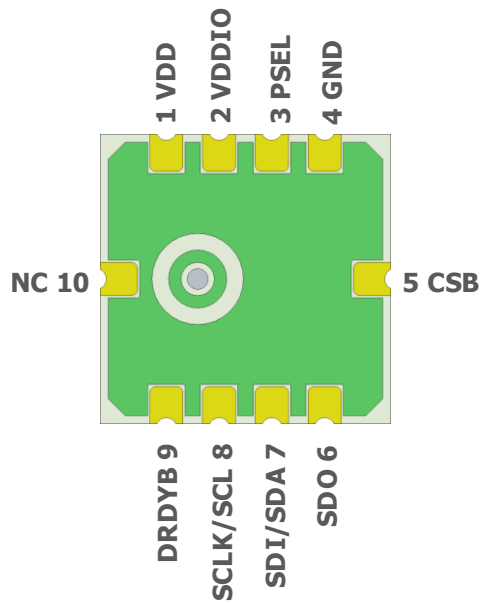

Fig. 3 Pin configuration (Bottom view)

## TERMINAL EXPLANATIONS

Table 1 Pin table

No.	Pin Name	Type	Function
1	VDD	I	Power-supply for analog circuit
2	VDDIO	I	Power-supply for digital I/O
3	PSEL	I	Protocol select terminal(High:SPI/Low:I2C) * PSEL is not pull-up / pull-down in the internal circuit. Please use it must be connected to VDDIO or GND.
4	GND	-	GND
5	CSB	I	Chip select for SPI communication *Please set to open circuit when I2C is used
6	SDO	O	Serial Data Output for SPI communication (SDO=MISO) *Please set to open circuit when I2C is used
7	SDI SDA	I I/O	Serial Data Input for SPI communication (SDI=MOSI) Serial Data (Input and output) for I2C communication (SDA)
8	SCLK SCL	I I/O	Serial clock for SPI communication (SCLK) Serial clock for I2C communication (SCL)
9	DRDYB	O	Output terminal which notifies the completion of pressure measurement and calculation correction (negative logic)
10	NC	-	No connect

## ABSOLUTE MAXIMUM RATINGS

(unless otherwise specified, Ta=25°C)

Item	Symbol	Min.	Max.	Unit
Storage temperature range	T <sub>STG</sub>	-20	70	°C
Analog supply voltage	VDD <sub>MAX</sub>	-0.3	4.0	V
Digital I/O voltage	VDDIO <sub>MAX</sub>	-0.3	4.0	V
Overpressure	P <sub>MAX</sub>	-100 (-13.33)	600 (80)	mmHg (kPa)
Pressure medium (note <sup>1</sup> )	-	AIR ( don't dewfall )		-

note<sup>1</sup>: Storage and operation in an environment of dry and non-corrosive gases.

## RECOMMENDED OPERATING CONDITIONS

(unless otherwise specified, Ta=25°C)

Item	Symbol	Min.	Typ.	Max.	Unit
Operating temperature range	T <sub>OPR</sub>	0	-	60	°C
Analog supply voltage	VDD <sub>OPR</sub>	1.7	3.4V	3.6	V
Digital I/O voltage	VDDIO <sub>OPR</sub>	1.14	-	3.6	V
Operating pressure range	P <sub>OPR</sub>	-30 (-4)	-	360 (47.99)	mmHg (kPa)

## ELECTRICAL CHARACTERISTICS

Analog characteristics  
(unless Ta=25°C, VDD=VDDIO=3.4V)

Item	Symbol	Condition	Min.	Typ.	Max.	Unit.
VDD Current consumption	I <sub>VDDact</sub>	Pressure measure active	520	650	780	μA
	I <sub>VDDsd</sub>	Shutdown	-	0.01	0.1	
VDDIO Current consumption	I <sub>VDDIOact</sub>	Pressure measure active	1.5	2.0	2.6	μA
	I <sub>VDDIOsd</sub>	Shutdown	-	0.1	1.0	
Conversion time	t <sub>con1</sub>	MODE1	15.250	15.625	16.000	msec
	t <sub>con2</sub>	MODE2	7.62	7.81	8.00	
	t <sub>con3</sub>	MODE3	3.81	3.91	4.00	
	t <sub>con4</sub>	MODE4 High Resolution Mode	244	250	256	

## Digital I/O

(unless otherwise specified,  $T_a=25^{\circ}\text{C}$ ,  $V_{DD}=V_{DDIO}=3.4\text{V}$ )

Item	Symbol	Conditions	Min.	Typ.	Max.	Unit
High level input voltage	$V_{IH}$	-	$0.8 \times V_{DDIO}$	-	$V_{DDIO} + 0.3$	V
Low level input voltage	$V_{IL}$	-	-0.3	-	$0.2 \times V_{DDIO}$	V
Output voltage High level	$V_{OH1}$	$V_{DDIO} \geq 2.0\text{V}$	$V_{DDIO} - 0.4$	-	-	V
	$V_{OH2}$	$V_{DDIO} < 2.0\text{V}$	$0.8 \times V_{DDIO}$	-	-	V
Output voltage Low level	$V_{OL1}$	$V_{DDIO} \geq 2.0\text{V}$	-	-	0.4	V
	$V_{OL2}$	$V_{DDIO} < 2.0\text{V}$	-	-	$0.2 \times V_{DDIO}$	V



Pressure sensor characteristics  
(unless otherwise specified, Ta=25°C, VDD=VDDIO=3.4V)

Item	Symbol	Condition	Min.	Typ.	Max.	Unit
Pressure resolution	P <sub>Res</sub>	-	-	0.001	-	mmHg
Pressure effective resolution	P <sub>Eres1</sub>	MODE1 (tcon1 = Typ. 15.625msec)	-	0.020	0.040	mmHg RMS
	P <sub>Eres2</sub>	MODE2 (tcon2 = Typ. 7.81msec)	-	0.028	0.056	
	P <sub>Eres3</sub>	MODE3 (tcon3 = Typ. 3.91msec)	-	0.040	0.080	
	P <sub>Eres4</sub>	MODE4 (tcon4 = Typ. 250msec)	-	0.005	0.010	
Pressure offset	P <sub>Off</sub>	No air pressure Ta = 5°C~45°C	-5	0	5	mmHg
Pressure span	P <sub>S</sub>	0 ~ 300mmHg Ta = 5°C~45°C	298.1	300	301.9	mmHg
Pressure linearity	P <sub>L</sub>	0 ~ 300mmHg Ta = 5°C~45°C	-0.6	0	0.6	mmHg
Pressure measurement error	P <sub>Err</sub>	0 ~ 300mmHg Ta = 5°C~45°C	-7	-	7	mmHg
Pressure measurement error - Pressure offset (note <sup>2</sup> )	P <sub>Err</sub> - P <sub>Err</sub>	0 ~ 300mmHg Ta = 5°C~45°C	-2	-	2	mmHg
		-10 ~ 330mmHg Ta = 5°C~45°C (note <sup>3</sup> )				

note<sup>2</sup>: It can take advantage of the performance to the fullest by canceling the pressure offset.

note<sup>3</sup>: This item is not inspected at the time of shipment.

Temperature sensor characteristics  
(unless otherwise specified, Ta=25°C, VDD=VDDIO=3.4V)

Item	Symbol	Conditions	Min.	Typ.	Max.	Unit
Temperature measurement error	T <sub>Err</sub>	5°C~ 45°C	-2.0	-	2.0	°C

Definition of characteristics

Pressure resolution  $P_{Res}$

This Value is equivalent to 1LSB of output digital value.

Pressure effective resolution  $P_{Eres}$

Measure 16 points after the pressure output is stable, and it is the standard deviation of the 16 points.

Pressure offset  $P_{Off}$

It is the output under no air pressure.

Pressure span  $P_S$

The difference between the pressure measurement value of 300mmHg and no air pressure..

Pressure linearity  $P_L$

It is the amount of deviation from the Ref. line that linked measurement value 0mmHg-300mmHg.

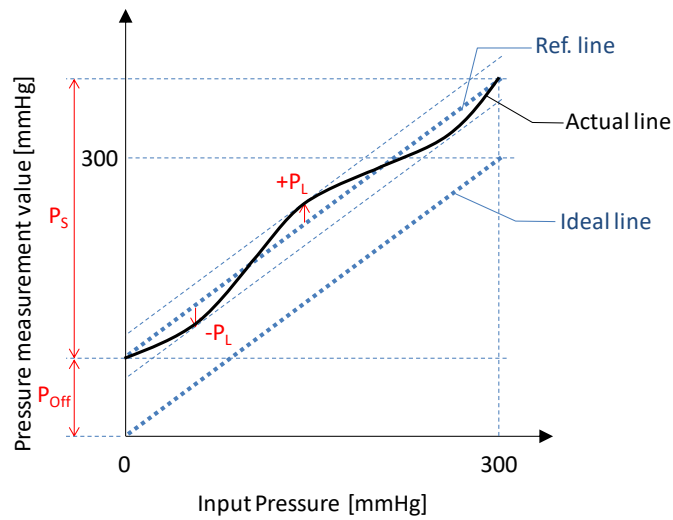

Fig. 4 Pressure offset, Pressure span, Pressure linearity

Pressure measurement error  $P_{Err}$

Pressure measurement error  $P_{Err}$  is the amount of deviation from the ideal line. It is the error integrated Pressure offset  $P_{Off}$ , Pressure span  $P_s$  error and Pressure linearity  $P_L$  error by the formula(1).

$$P_{Err} = P_{Off} + \sqrt{(P_{Serr}^2 + P_L^2)} \quad [mmHg] \quad (1)$$

$P_{Serr}$  : Error of  $P_s$

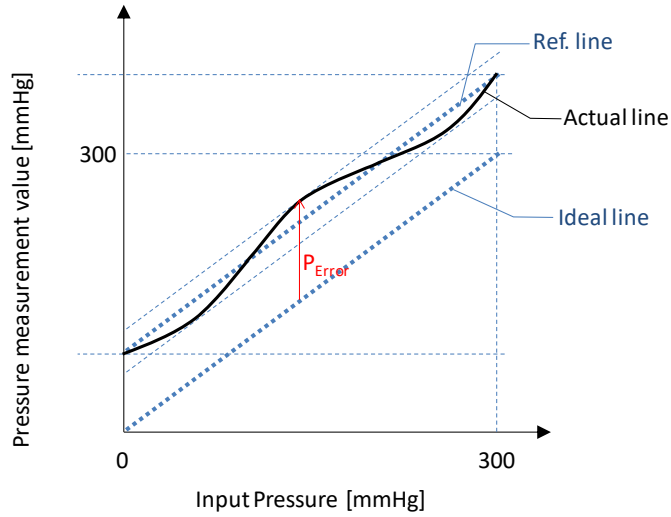

Fig. 5 Pressure measurement error

## FUNCTION EXPLANATION

### Function Outline

The MMR902 is consists of piezoresistive pressure sensor and an analog front end IC.

It converts analog output voltage from piezoresistive pressure sensor to digital value of 24 bits, and corrects and outputs variations of sensor characteristics due to variations of temperature and process.

Flow chart of pressure/temperature measurement

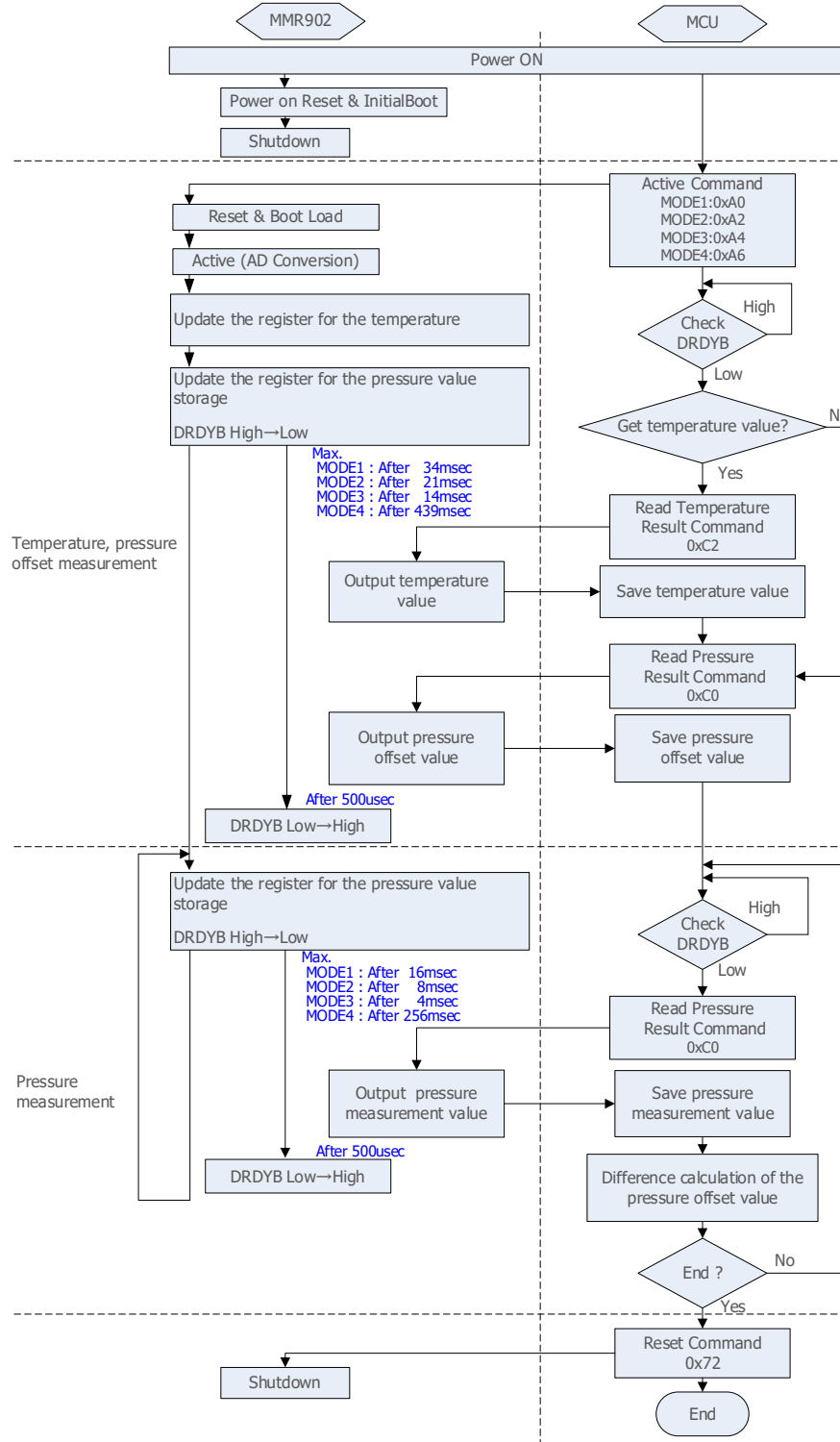

Fig. 6 Flow chart of pressure/temperature measurement

Product code

Product code has been recorded in internal memory (NVM(Non-volatile memory)) of the MMR902. Product code can be obtained by the process of Fig. 7

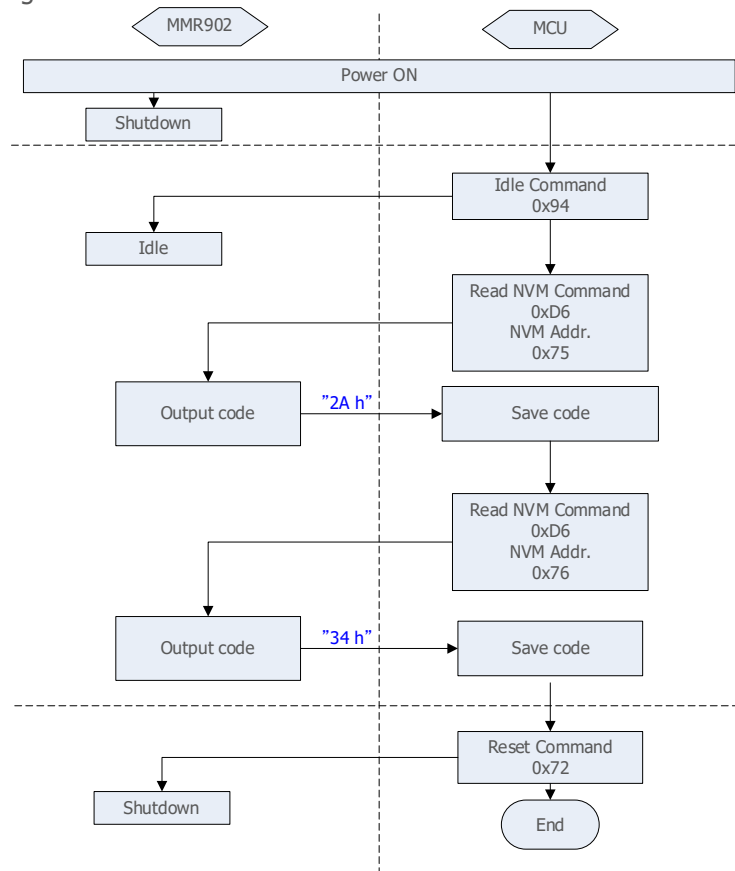

Fig. 7 Flow chart of product code gets

Table 2 Description of the product code

MMR90 (1) (2) A			
	NVM Addr.	Data	Description
(1)	0x75	2A h	Model name and Rank. 2: It shows the MMR902. A: It shows the A rank.
(2)	0x76	34 h	Power-supply voltage in the correction. 34: It shows that it was corrected at 3.4V.

SERIAL COMMUNICATION INTERFACE

It supports SPI and I2C as an interface for serial communication. SPI (max. 5Mbps) or I2C (max.3.4Mbps) can be selected by PSEL terminal. When PSEL terminal is set to High, SPI will be selected. When it is set to Low, I2C will be selected. Please set High voltage of PSEL terminal the same potential as VDDIO terminal.

## Baud rate

※ This item is not inspected at the time of shipment.  
(unless otherwise specified,  $T_a=25^{\circ}\text{C}$ ,  $V_{DD}=3.4\text{V}$ )

Item	Symbol	Conditions	Min.	Typ.	Max.	Unit
I2C communication speed	BR <sub>I2C1</sub>	VDDIO $\geq$ 2.0V Cb $\leq$ 100pF	-	-	3.4	Mbps
	BR <sub>I2C2</sub>	VDDIO < 2.0V Cb<100pF	-	-	0.4	
	BR <sub>I2C3</sub>	VDDIO $\geq$ 2.0V Cb $\leq$ 400pF	-	-	1.7	
	BR <sub>I2C4</sub>	VDDIO < 2.0V Cb<400pF	-	-	0.4	
SPI communication speed	BR <sub>SPI1</sub>	VDDIO $\geq$ 2.0V Cb $\leq$ 100pF	-	-	5.0	
	BR <sub>SPI2</sub>	VDDIO < 2.0V Cb<100pF	-	-	1.0	
	BR <sub>SPI3</sub>	VDDIO $\geq$ 2.0V Cb $\leq$ 400pF	-	-	2.5	
	BR <sub>SPI4</sub>	VDDIO < 2.0V Cb<400pF	-	-	0.5	

SPI format

SPI command format is shown below. Data send/receive is started when CSB becomes low level from the status when SCLK is high level. Input data is sampled on rising edges of the SCLK. (SPI MODE 3) For the detailed timing, please refer to the each command format.

SPI Operation Command format

Corresponding Command

- Reset Command (0x72)
- Active Command (0xA0, 0xA2, 0xA4, 0xA6)
- Idle Command (0x94)

Please send command code of 8 bits. When their commands are received, it turns over ACK to 8 bits and it performs operation corresponding to each command.

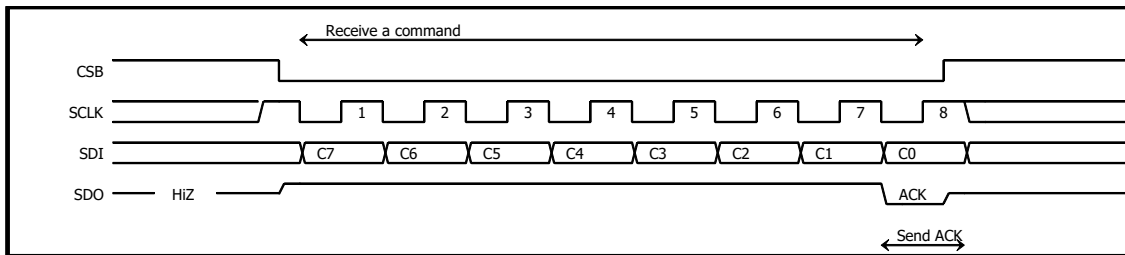

Fig. 8 SPI operation command format

SPI Result command format

Please send reset command or active command of 8 bits. When the command is received, it turns over ACK to 8 bits and it outputs the data at 24 bits, MSB first. At the Status command, it is immediately output from D7 to D0 after ACK transmission.

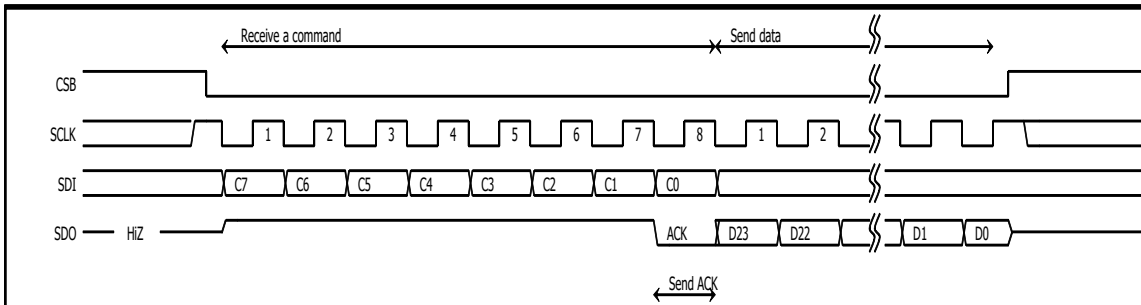

Fig. 9 SPI Result command format (during 24-bit data output.)



SPI Read command format

Corresponding Command  
 ·Read NVM command (0xD6)

Please send command code of 8 bits. When their commands are received, it turns over ACK to 8 bits. Then please send the memory address of 8bits (0x75 or 0x76). After receiving memory address, the internal area becomes busy for the maximum 25usec in order to prepare for data sending. During this time, 00h which indicates busy is output. When the preparation of data is completed, 01h is output, and continuously, 8bit data is output.

How to discern busy:

After sending writing data, continue to input clock with maintaining communicating mode. Then, 00h is output to indicate that it is busy. When the writing has been completed, 01h will be output. \*The "00h" to indicate busy may sometimes be output or not depending on the clock frequency.

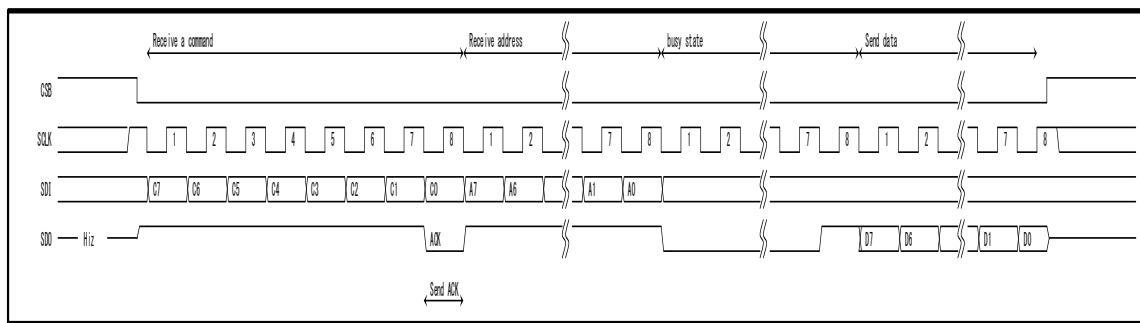

Fig. 10 SPI Read command format

SPI AC Characteristics

※ This item is not inspected at the time of shipment.

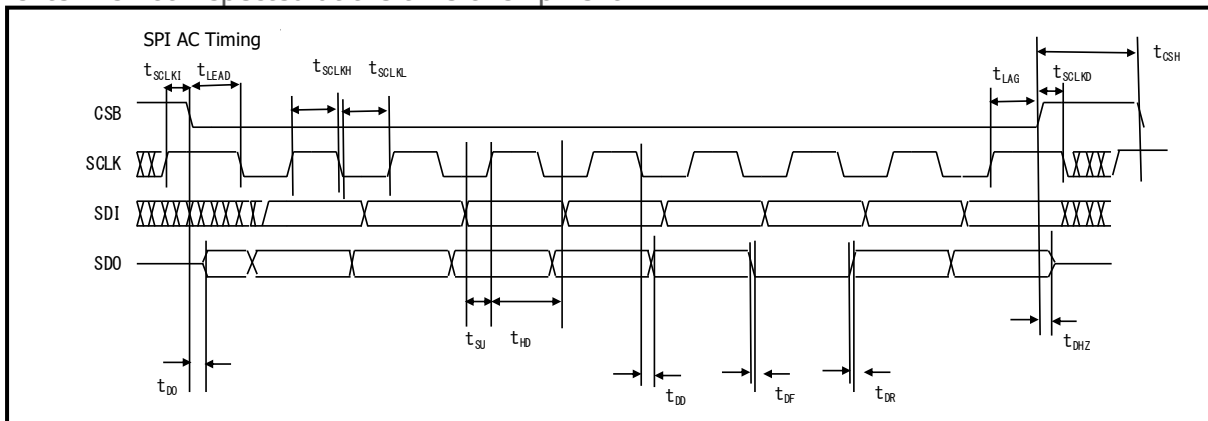

Fig. 11 SPI AC timing chart

Table 3 SPI AC Characteristics

Items	Symbol	VDDIO<2V		VDDIO≥2V		Unit
		min.	max.	min.	max.	
SCLK frequency (Duty 50±10%)	$f_{SCLK}$	-	1	-	5	MHz
SCLK High period (90%~90%)	$t_{SCLKH}$	400		80	-	ns
SCLK Low period (10%~10%)	$t_{SCLKL}$	400		80	-	ns
SCLK standby time	$t_{SCLKI}$	500	-	100	-	ns
SCLK delay time	$t_{SCLKD}$	0	-	0	-	ns
CSB High period (90%~90%)	$t_{CSH}$	1000	-	200	-	ns
Time from CSB falling edge to SCLK falling edge	$t_{LEAD}$	0	-	0	-	ns
Time from SCLK rising edge to CSB rising edge	$t_{LAG}$	500	-	100	-	ns
SDI setup time	$t_{SU}$	100	-	10	-	ns
SDI hold time	$t_{HD}$	10	-	10	-	ns
SDO rise time (Load: 100pF)(10%~90%)	$t_{DR}$		50	-	50	ns
SDO fall time (Load: 100pF) (10%~90%)	$t_{DF}$		50	-	50	ns
SDO output delay time (Load: 100pF)	$t_{DDY}$	-	120	-	60	ns
SDO output delay time (Load 100pF) from CSB became Low	$t_{ACC}$	-	120	-	60	ns
Time from CSB reaches High to SDO reaches HiZ (Load: 100pF)	$t_{DHZ}$	-	170	-	170	ns

I2C format

I2C address is the total of 8 bits ; The first 7 bits are slave address and the rest of 1 bit is R/W bit. Slave address for MMR902 (7 bits) is 0x65. I2C address (8 bits) will be 0xCA(Write) and 0xCB(Read) by combining with R/W bit.

Table 4 I2C address

HEX.	I2C Address (8 bit)							
	Slave address (7 bit)							R/W bit
	A6	A5	A4	A3	A2	A1	A0	
0xCA	1	1	0	0	1	0	1	0
0xCB	1	1	0	0	1	0	1	1

I2C Operation command format

Corresponding Command

- Reset Command (0x72)
- Active Command (0xA0, 0xA2, 0xA4, 0xA6)
- Idle Command (0x94)

Please send I2C address of 8 bits (0xCA) by Write Mode. When the command is received, it turns over ACK to 9 bits. Then please send command code of 8bits. When the command is received, it turns over ACK to 9 bits and it performs operation corresponding to each command.

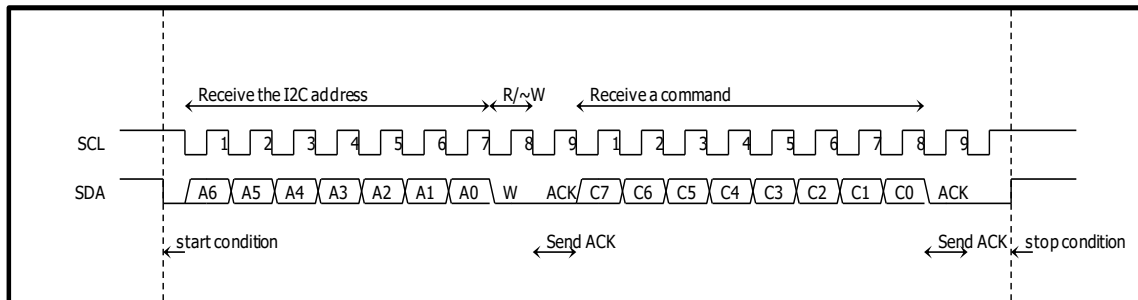

Fig.12 I2C Operation command format

I2C Result command format

Please send I2C address of 8 bits (0xCA) and the command by Write Mode. When the address and the command is received, it turns over ACK to 9 bits. Then please send I2C address of 8 bits (0xCB) by Read Mode. When the address is received, it turns over ACK to 9 bits and it outputs the data at 24 bits in steps of 8 bits, MSB first. Please send ACK every 8 bits. At the status command, only 8-bit data from D7 to D0 is output.

MMR902 quits immediately communication when receiving NACK.

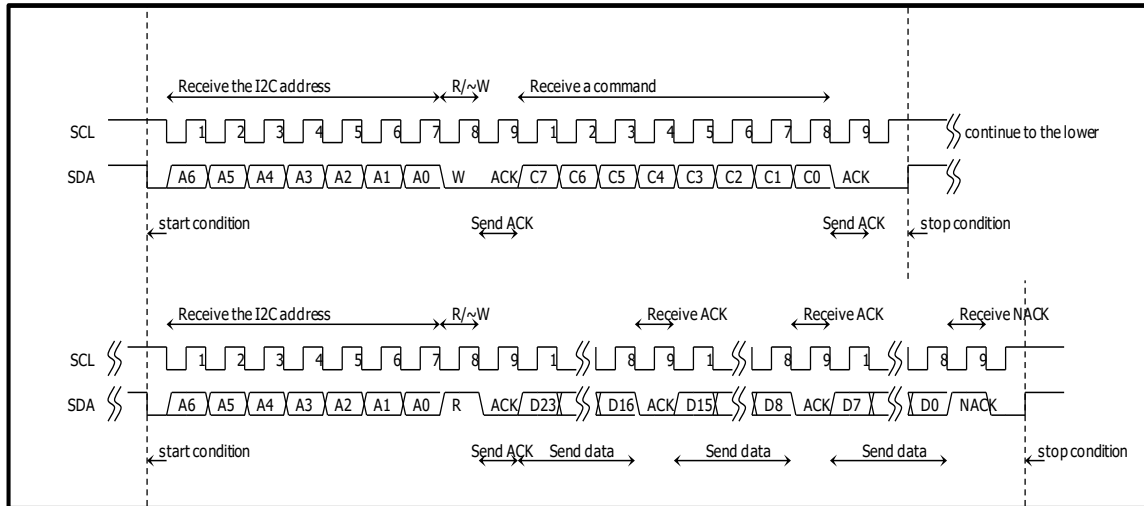

Fig. 13 I2C Result command format

I2C Read command format

Please send I2C address of 8 bits (0xCA) and the command by Write Mode. When the address and the command is received, it turns over ACK to 9 bits. Then please send the memory address of 8bits (0x75 or 0x76). After receiving memory address, it becomes busy during preparing to send data. During this time, SCL becomes Low. SCL is released when data-preparation is completed. Then please send I2C address of 8 bits (0xCB) by Read Mode. When the address is received, it turns over ACK to 9 bits and it outputs the data at 8 bits.

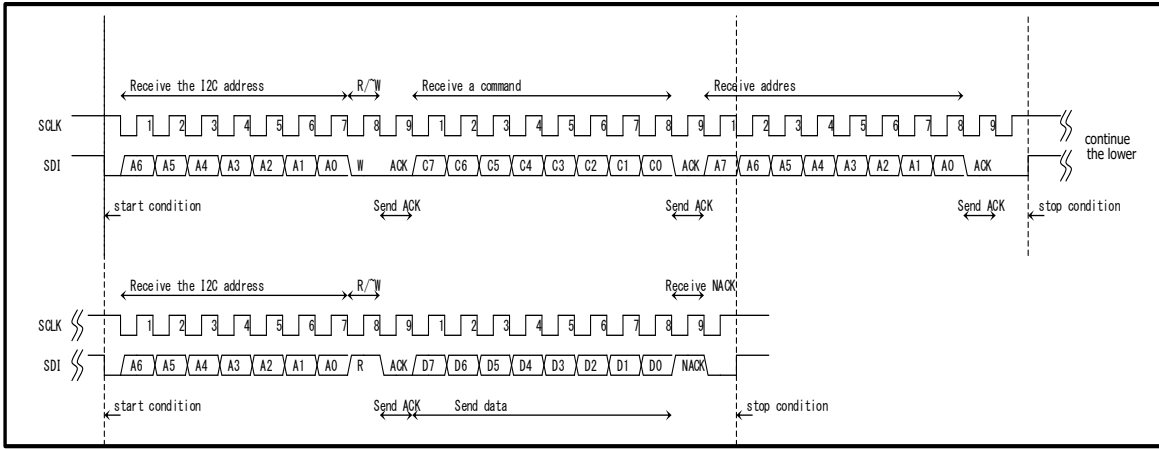

Fig. 14 I2C Read command format

I2C AC Characteristics

※ This item is not inspected at the time of shipment

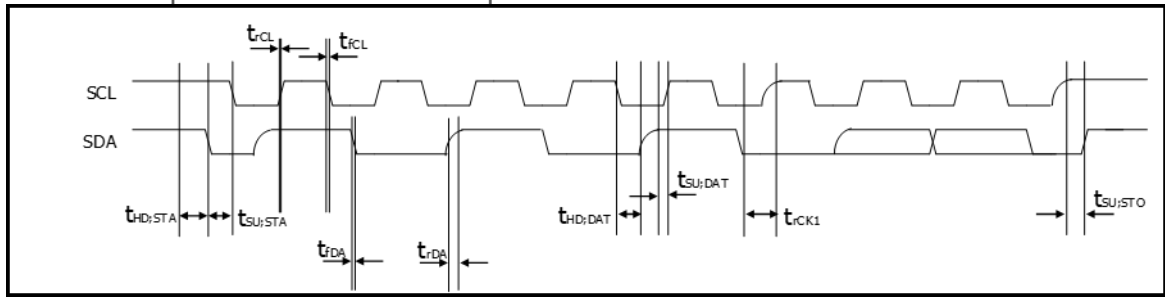

Fig.15 I2C AC timing char

Table 5 I2C AC Characteristics

Items	Symbol	VDDIO < 2.0V		VDDIO ≥ 2.0V				Unit
		Fast mode		Hsmode				
				Cb=100pF		Cb=400pF		
		min.	max.	min.	max.	min.	max.	
SCL frequency	$f_{SCL}$	0	400kHz	0	3.4	0	1.7	MHz
Start condition setup time	$t_{SU;STA}$	600	-	160	-	160	-	ns
Start condition hold time	$t_{HD;STA}$	600	-	160	-	160	-	ns
Stop condition setup time	$t_{SU;STO}$	600	-	160	-	160	-	ns
Data setup time	$t_{SU;DAT}$	100	-	20	-	20	-	ns
Data hold time (note <sup>4</sup> )	$t_{HD;DAT}$	20	-	20	70	20	150	ns
SCL rise time	$t_{rCL}$	-	300	10	40	20	80	ns
Rise time of SCL after ACK (When clock stretch is released.)	$t_{rCL1}$	-	300	10	80	20	160	ns
SCL fall time	$t_{fCL}$	10	300	10	-	20	80	ns
SDA rise time	$t_{rDA}$	-	300	10	80	20	160	ns
SDA fall time	$t_{fDA}$	10	300	10	80	20	160	ns

note<sup>4</sup>: This product does not have the function to retain data in SDA.  
Please ensure the hold of SDA with 20nsec for the area where SCL falling edge is not defined.

Command code

Table 6 Operation command list

Command Name		Command Code									Action
		HEX.	BIN.								
			C7	C6	C5	C4	C3	C2	C1	C0	
Reset		0x72	0	1	1	1	0	0	1	0	Reset and Return to Shutdown state
Idle		0x94	1	0	0	1	0	1	0	0	Shift to Idle state
Active	Measure at MODE 1	0xA0	1	0	1	0	0	0	0	0	Start measure at MODE1
	Measure at MODE 2	0xA2	1	0	1	0	0	0	1	0	Start measure at MODE2
	Measure at MODE 3	0xA4	1	0	1	0	0	1	0	0	Start measure at MODE3
	Measure at MODE 4	0xA6	1	0	1	0	0	1	1	0	Start measure at MODE4

Table 7 Result code list

Command Name	Command Code									Action																																			
	HEX.	BIN.																																											
		C7	C6	C5	C4	C3	C2	C1	C0																																				
Read Temperature Result	0xC0	1	1	0	0	0	0	0	0	Read pressure result																																			
	<p>Read compensated pressure result.                      It outputs the result of pressure measurement at 24bits, MSB first.                      A negative number is expressed by 2's complement.                      About output range, in case of positive output : 000000 h ~ 7FFFFFFF h (in decimal number : 0 ~ 8388607), in case of negative output : FFFFFFFF h ~ 800000 h (in decimal number : -1 ~ -8388608)                      However, the result of measurement when being used beyond a recommended operating condition can't be guaranteed.</p> <p>Pressure value = DEC. / 1000</p> <p>Output example:</p> <table border="1"> <thead> <tr> <th>BIN.</th> <th>HEX.</th> <th>DEC.</th> <th>Pressure</th> </tr> </thead> <tbody> <tr> <td>111111111110100010010000 b</td> <td>FFE890 h</td> <td>-6000</td> <td>-6.000mmHg</td> </tr> <tr> <td>000000000000000000000000 b</td> <td>000000 h</td> <td>0</td> <td>0.000mmHg</td> </tr> <tr> <td>000001001001001111100000 b</td> <td>0493E0 h</td> <td>300000</td> <td>300.000mmHg</td> </tr> </tbody> </table>										BIN.	HEX.	DEC.	Pressure	111111111110100010010000 b	FFE890 h	-6000	-6.000mmHg	000000000000000000000000 b	000000 h	0	0.000mmHg	000001001001001111100000 b	0493E0 h	300000	300.000mmHg																			
BIN.	HEX.	DEC.	Pressure																																										
111111111110100010010000 b	FFE890 h	-6000	-6.000mmHg																																										
000000000000000000000000 b	000000 h	0	0.000mmHg																																										
000001001001001111100000 b	0493E0 h	300000	300.000mmHg																																										
Read Temperature Result	0xC2	1	1	0	0	0	0	1	0	Read temperature result																																			
	<p>Read compensated temperature result.                      It outputs the result of pressure measurement at 24bits, MSB first.                      A negative number is expressed by 2's complement.                      About output range, in case of positive output : 000000 h ~ 7FFFFFFF h (in decimal number : 0 ~ 8388607), in case of negative output : FFFFFFFF h ~ 800000 h (in decimal number : -1 ~ -8388608)                      However, the result of measurement when being used beyond a recommended operating condition can't be guaranteed.</p> <p>Temperature value = DEC. / 2<sup>16</sup></p> <p>Output example:</p> <table border="1"> <thead> <tr> <th>BIN.</th> <th>HEX.</th> <th>DEC.</th> <th>Temperature</th> </tr> </thead> <tbody> <tr> <td>000001010000000000000000 b</td> <td>050000 h</td> <td>327680</td> <td>5.000 °C</td> </tr> <tr> <td>000110010000000000000000 b</td> <td>190000 h</td> <td>1638400</td> <td>25.000 °C</td> </tr> <tr> <td>001011010000000000000000 b</td> <td>2D0000 h</td> <td>2949120</td> <td>45.000 °C</td> </tr> </tbody> </table>										BIN.	HEX.	DEC.	Temperature	000001010000000000000000 b	050000 h	327680	5.000 °C	000110010000000000000000 b	190000 h	1638400	25.000 °C	001011010000000000000000 b	2D0000 h	2949120	45.000 °C																			
BIN.	HEX.	DEC.	Temperature																																										
000001010000000000000000 b	050000 h	327680	5.000 °C																																										
000110010000000000000000 b	190000 h	1638400	25.000 °C																																										
001011010000000000000000 b	2D0000 h	2949120	45.000 °C																																										
Status	0x80	1	0	0	0	0	0	0	0	Read pressure result																																			
	<p>Output 8bits data depending on the IC conditions</p> <table border="1"> <thead> <tr> <th>D7</th> <th>D6</th> <th>D5</th> <th>D4</th> <th>D3</th> <th>D2</th> <th>D1</th> <th>D0</th> <th>State</th> </tr> </thead> <tbody> <tr> <td>0</td> <td>0</td> <td>0</td> <td>0</td> <td>0</td> <td>0</td> <td>0</td> <td>0</td> <td>Shutdown</td> </tr> <tr> <td>1</td> <td>1</td> <td>1</td> <td>0</td> <td>0</td> <td>1</td> <td>0</td> <td>1</td> <td>Idle</td> </tr> <tr> <td>1</td> <td>1</td> <td>1</td> <td>0</td> <td>1</td> <td>1</td> <td>0</td> <td>1</td> <td>Active</td> </tr> </tbody> </table>										D7	D6	D5	D4	D3	D2	D1	D0	State	0	0	0	0	0	0	0	0	Shutdown	1	1	1	0	0	1	0	1	Idle	1	1	1	0	1	1	0	1
D7	D6	D5	D4	D3	D2	D1	D0	State																																					
0	0	0	0	0	0	0	0	Shutdown																																					
1	1	1	0	0	1	0	1	Idle																																					
1	1	1	0	1	1	0	1	Active																																					

Table 8 Read command list

Command Name	Command Code									Action
	HEX.	BIN.								
		C7	C6	C5	C4	C3	C2	C1	C0	



---

Read NVM	0xD6	1	1	0	1	0	1	1	0	Read data from NVM
----------	------	---	---	---	---	---	---	---	---	--------------------

State transition table

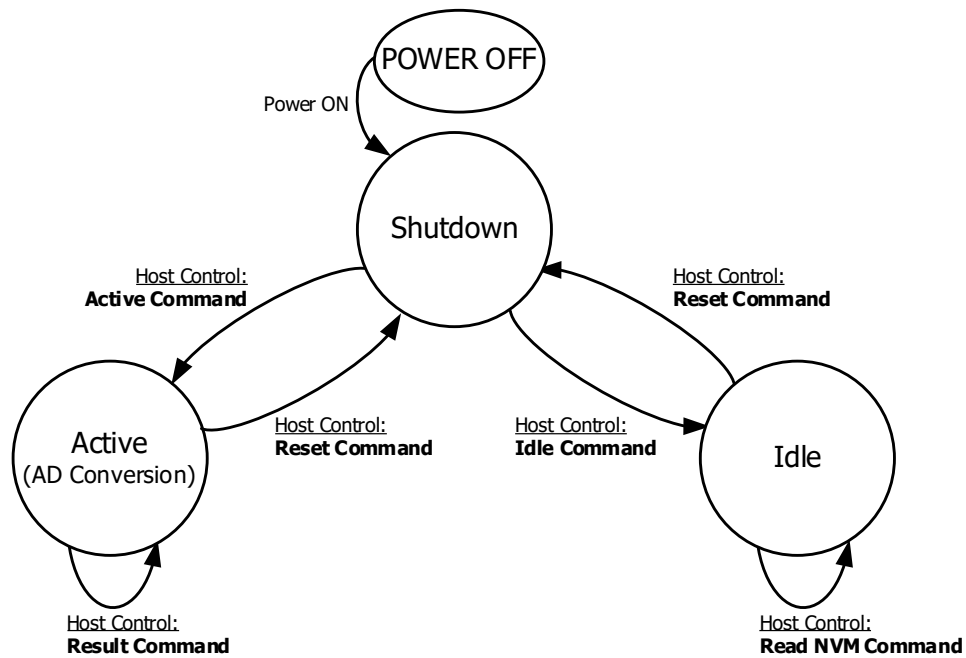

Fig. 16 State transition diagram

Table 9 State transition table

Command \ State	Shutdown	Active	Idle
Reset	Power on Reset & InitialBoot =>Shutdown	Power on Reset & InitialBoot =>Shutdown	Power on Reset & InitialBoot =>Shutdown
Active	Reset & Boot Load =>Active state (AD conversion)	Ignore(note <sup>5</sup> ) =>Keep state	=>Active state (AD conversion)
Result	Ignore(note <sup>5</sup> ) =>Keep state	Output result =>Keep state	Do not issue(note <sup>6</sup> ) =>Keep state
Idle	Power on Reset & InitialBoot =>Idle state	=>Idle state	=>Keep state
Read NVM	Ignore(note <sup>5</sup> ) =>Keep state	Do not issue(note <sup>7</sup> ) =>Keep state	Output code =>Keep state
Status	Output code =>Keep state	Output code =>Keep state	Output code =>Keep state

note<sup>5</sup>: NACK is returned to the command.

note<sup>6</sup>: The correct result isn't output. Additionally, ACK is returned to the command.

note<sup>7</sup>: Although command is acceptable, it goes unintended behavior since sequence is running.

Timing Chart

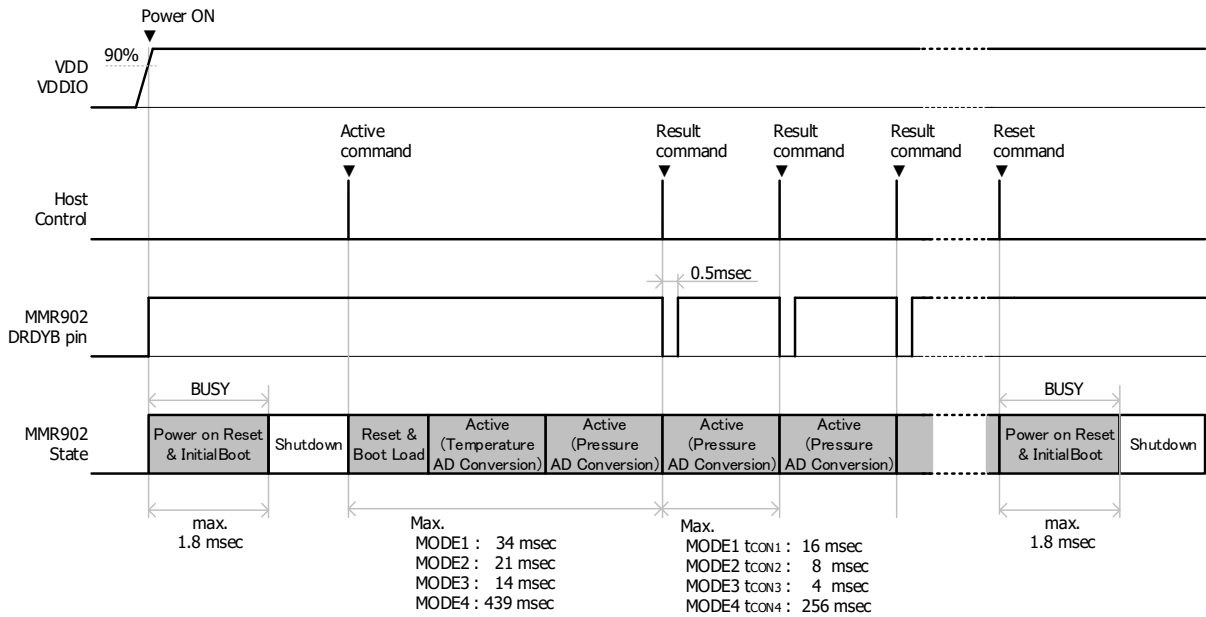

Fig. 17 Timing Chart

note<sup>8</sup>: Power on reset voltage is set to 1.62V in case of VDD<1.8V, and set to 1.08V in case of VDDIO<1.2V.

TYPICAL APPLICATION CIRCUIT

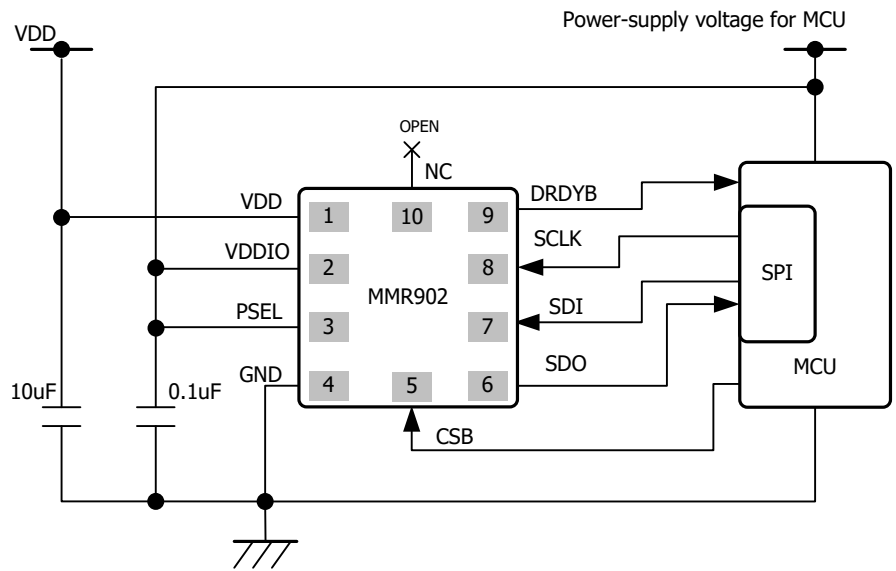

Fig. 18 Typical Electrical Connection (SPI)

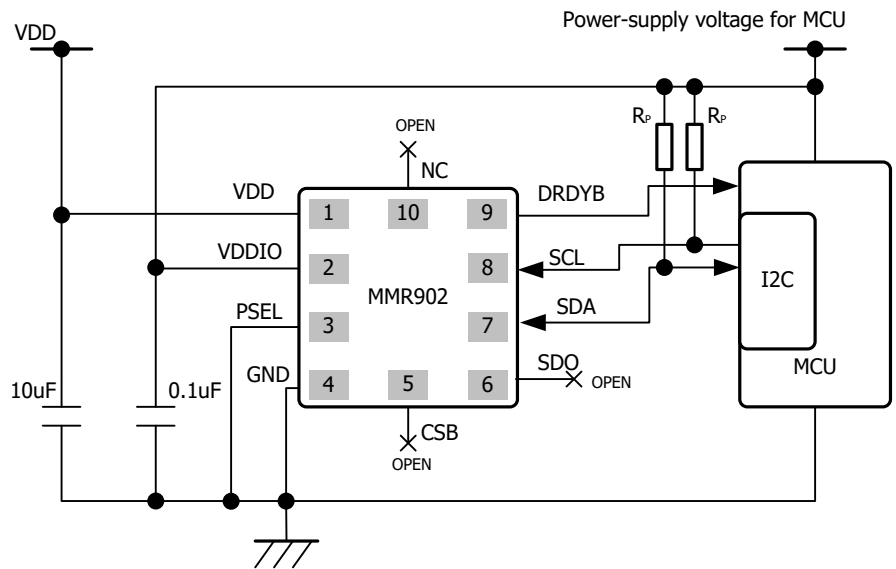

Fig. 19 Typical Electrical Connection (I2C)

TYPICAL PERFORMANCE CHARACTERISTICS

(unless otherwise specified,  $T_a=25^{\circ}\text{C}$ ,  $V_{DD}=V_{DDIO}=3.4\text{V}$ )

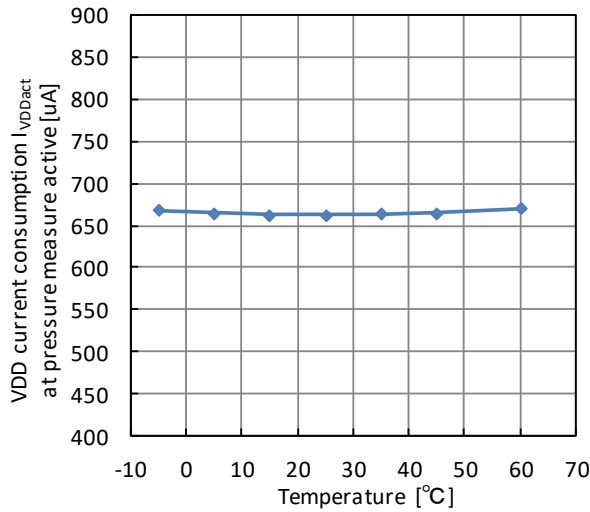

Fig.20.1 VDD current consumption  $I_{VDDact}$  at pressure measure active temperature characteristic

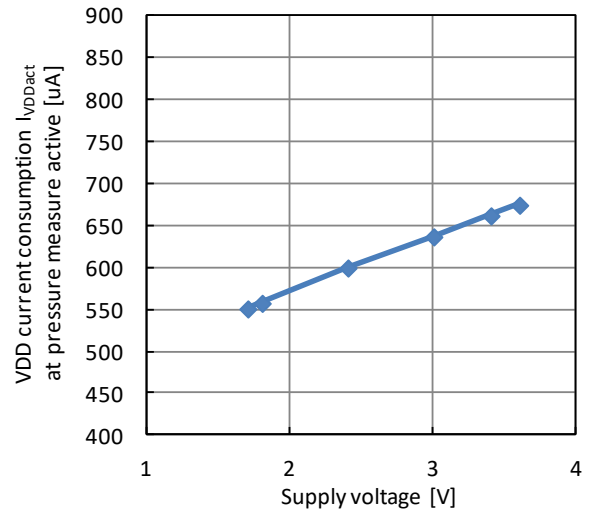

Fig.20.2 VDD current consumption  $I_{VDDact}$  at pressure measure active supply voltage characteristic

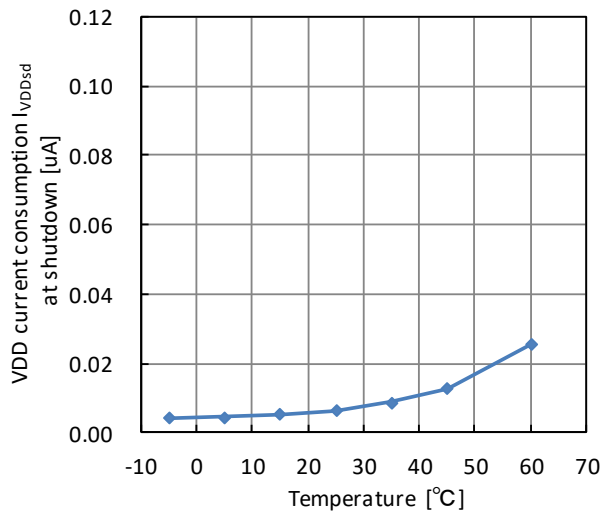

Fig.20.3 VDD current consumption  $I_{VDDsd}$  at shutdown temperature characteristic

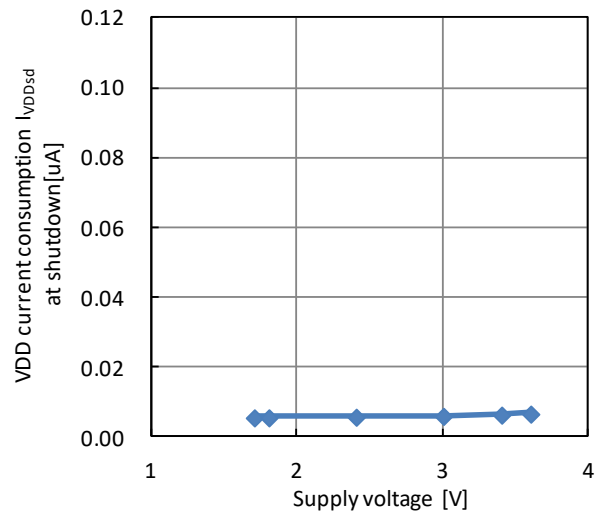

Fig.20.4 VDD current consumption  $I_{VDDsd}$  at shutdown supply voltage characteristic

(unless otherwise specified,  $T_a=25^\circ\text{C}$ ,  $V_{DD}=V_{DDIO}=3.4\text{V}$ )

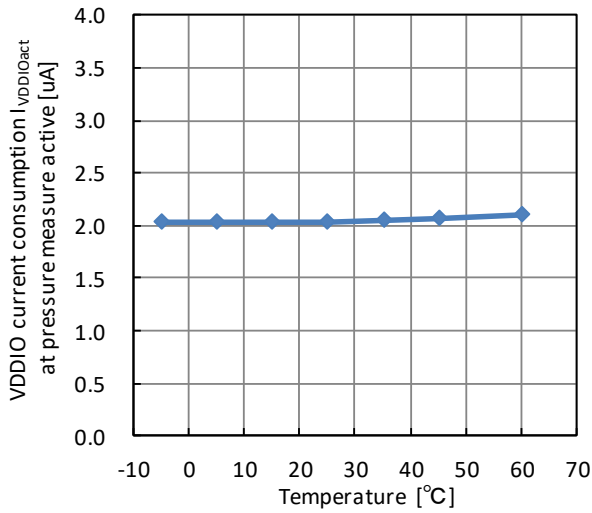

Fig.20.5 VDDIO current consumption  $I_{VDDIOact}$  at pressure measure active temperature characteristic

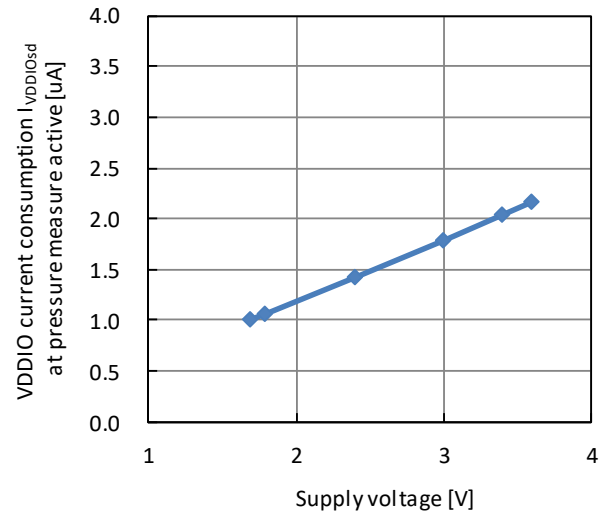

Fig.20.6 VDDIO current consumption  $I_{VDDIOact}$  at pressure measure active supply voltage characteristic

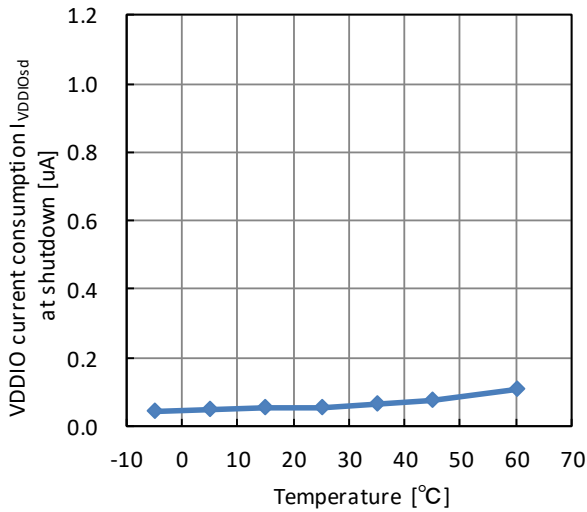

Fig.20.7 VDDIO current consumption  $I_{VDDIOsd}$  at shutdown temperature characteristic

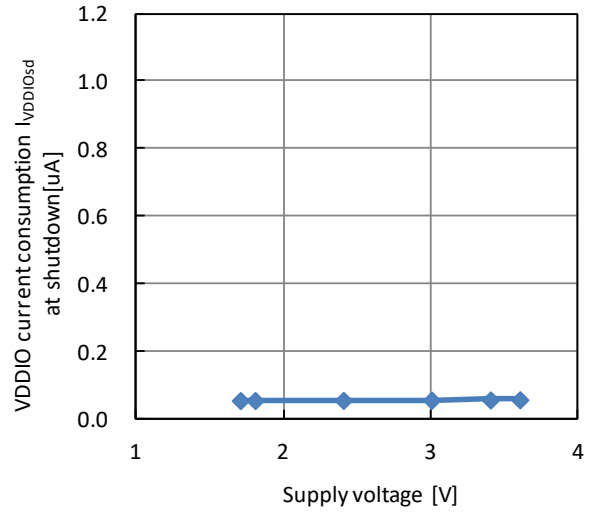

Fig.20.8 VDDIO current consumption  $I_{VDDIOsd}$  at shutdown supply voltage characteristic

(unless otherwise specified, Ta=25°C, VDD=VDDIO=3.4V)

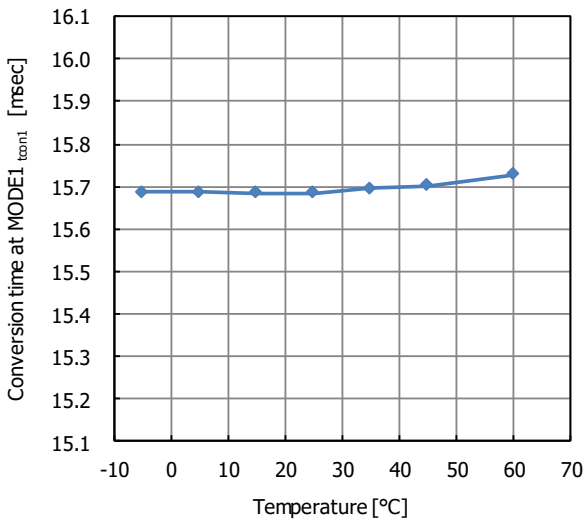

Fig.20.9 Conversion time at MODE 1 temperature characteristic

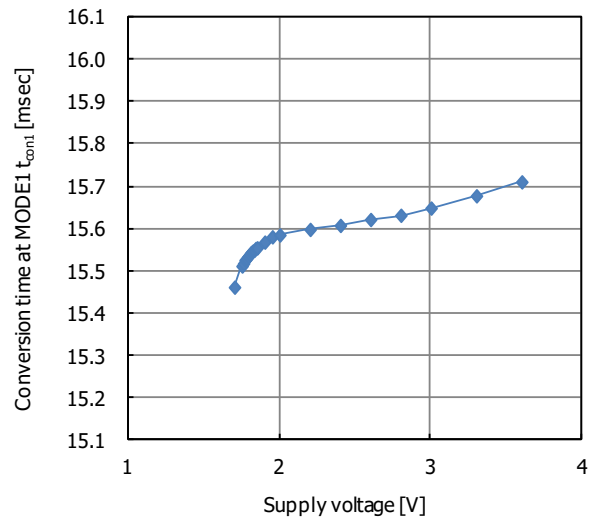

Fig.20.10 Conversion time at MODE 1 supply voltage characteristic

(unless otherwise specified, Ta=25°C, VDD=VDDIO=3.4V)

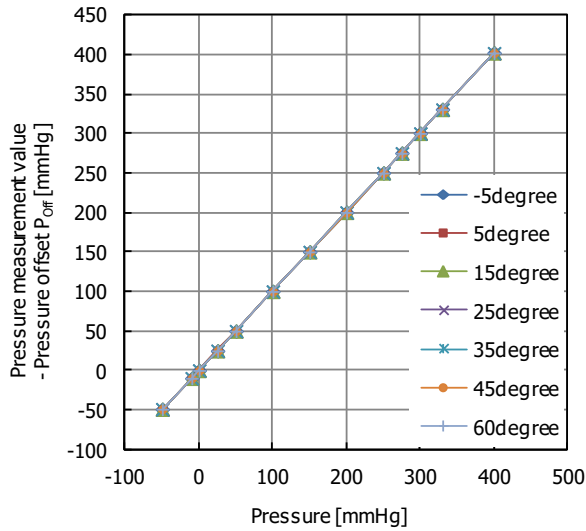

Fig.20.11 Pressure measurement value - Pressure offset P<sub>Off</sub> temperature characteristic (note<sup>9</sup>)

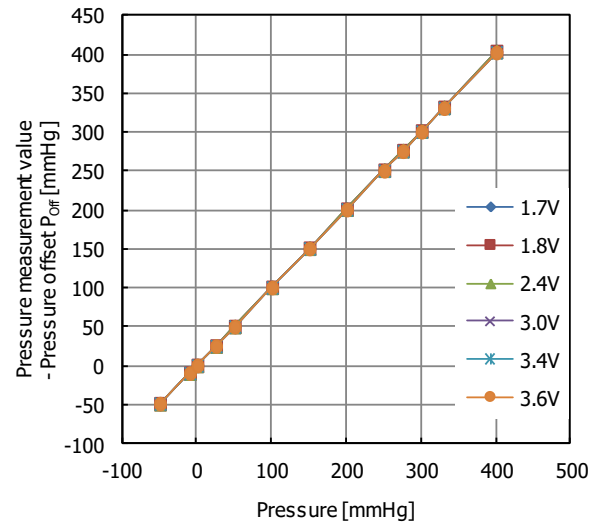

Fig.20.12 Pressure measurement value - Pressure offset P<sub>Off</sub> supply voltage characteristic (note<sup>9</sup>)

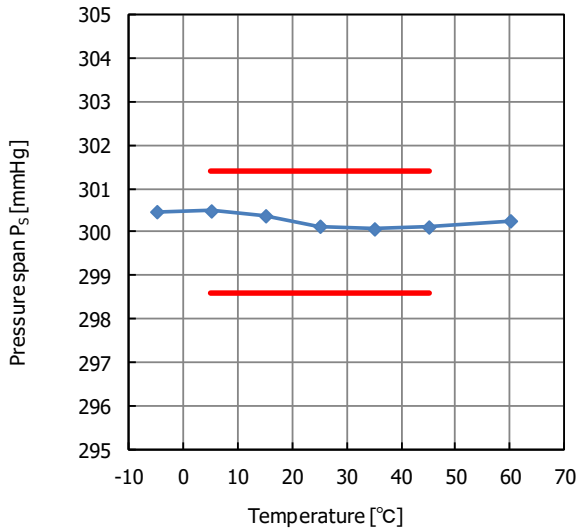

Fig.20.13 Pressure span P<sub>s</sub> temperature characteristic (note<sup>9</sup>)

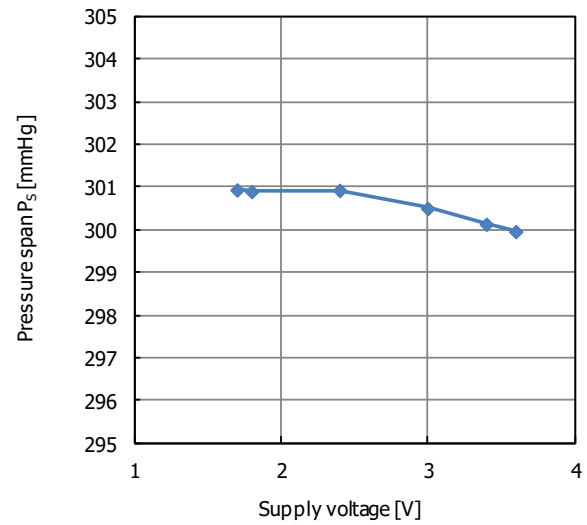

Fig.20.14 Pressure span P<sub>s</sub> supply voltage characteristic (note<sup>9</sup>)

note<sup>9</sup>: Corrected at 3.4V.



(unless otherwise specified,  $T_a=25^\circ\text{C}$ ,  $V_{DD}=V_{DDIO}=3.4\text{V}$ )

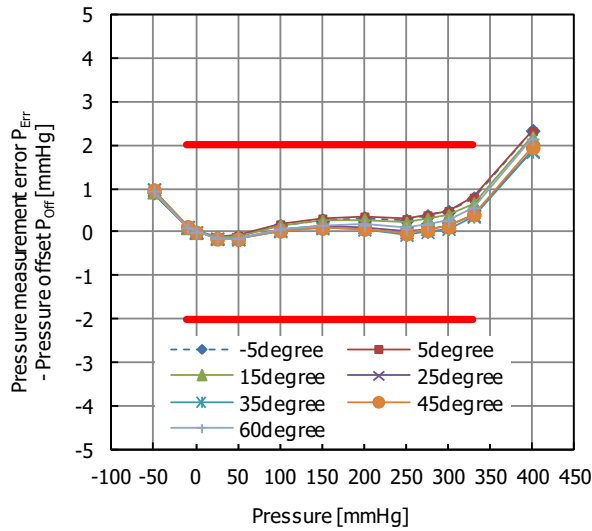

Fig.20.15 Pressure measurement error  $P_{Err}$  - Pressure offset  $P_{Off}$  temperature characteristic (note<sup>9</sup>)

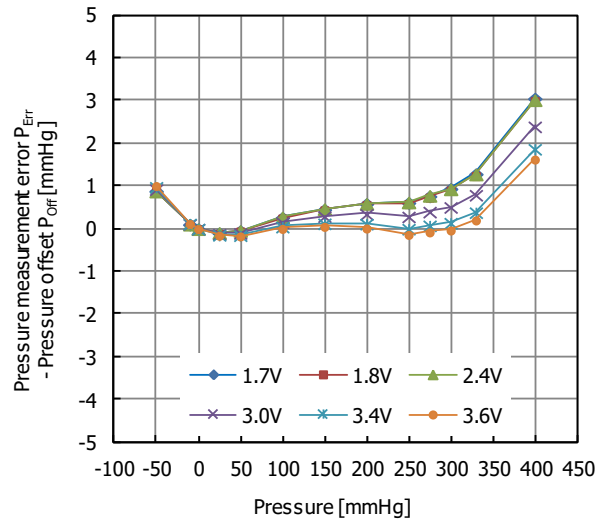

Fig.20.16 Pressure measurement error  $P_{Err}$  - Pressure offset  $P_{Off}$  supply voltage characteristic (note<sup>9</sup>)

note<sup>9</sup>: Corrected at 3.4V.

DIMENSIONS

Package Name: MEMS10A

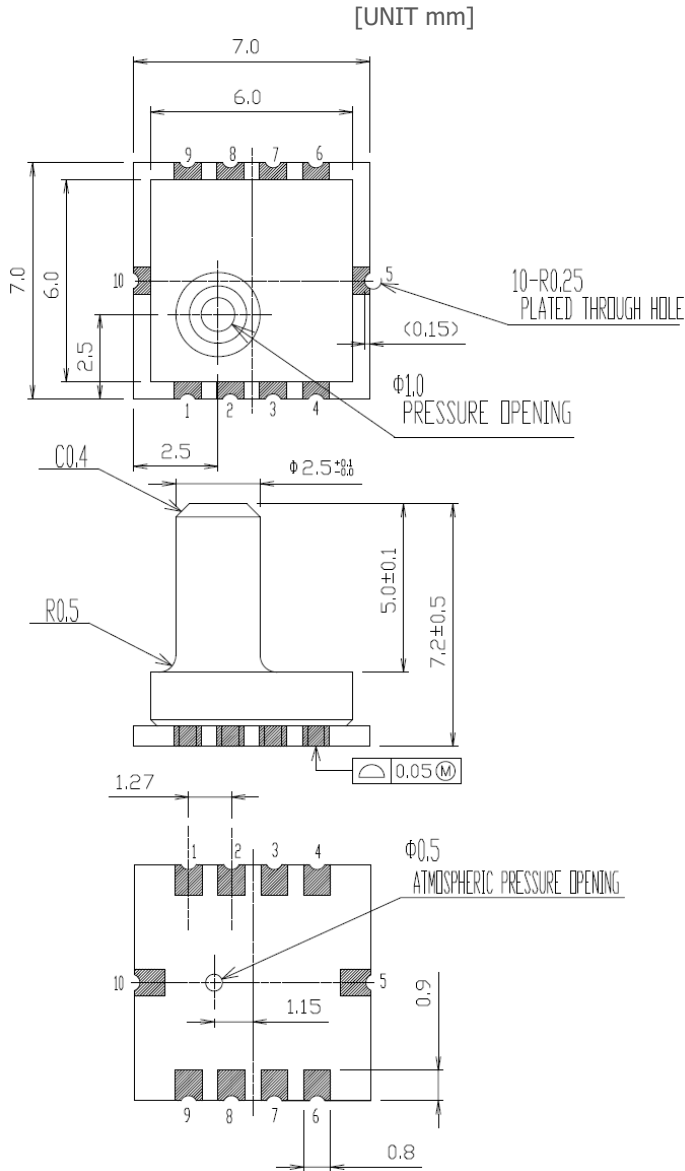

Table 10.1 Terminal list

Pin No.	Name
1	VDD
2	VDDIO
3	PSEL
4	GND
5	CSB
6	SDO
7	SDI/SDA
8	SCLK/SCL
9	DRDYB
10	NC

Table 10.2 Print circuit board specifications

Grade	FR-4
UL	94V-0
Thickness	$0.6 \pm 0.1$
Structure	2Layers PCB with through holes
Parts assemble	One side
Solder resist	Both side

PRODUCT NAME

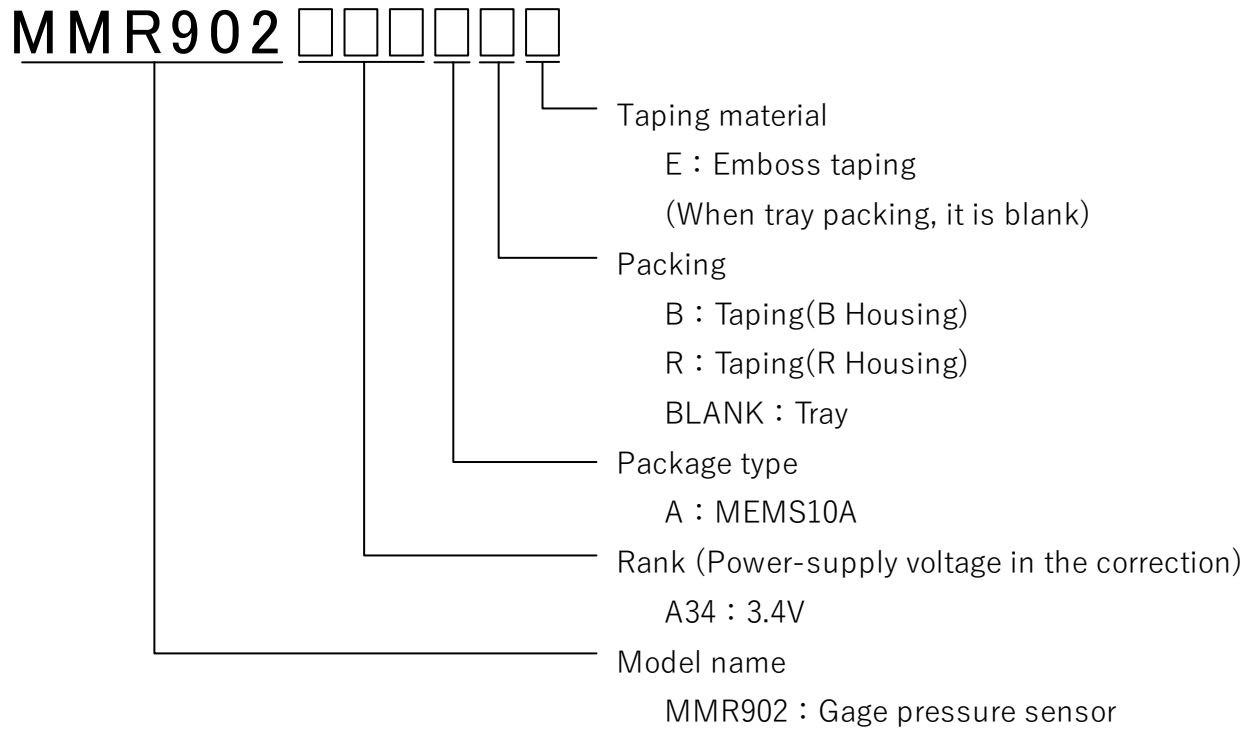

PRODUCT LINEUP

Product Name	Packing	Status
MMR902A34A	Tray	MP
MMR902A34ABE	Taping(B)	Developing
MMR902A34ARE	Taping(R)	Developing

## PRESSURE SENSOR LINEUP

Function	Product Name	Size (L x W x H) [mm]	Pressure Range [Pa]	Full Scale [Pa]	Pressure Measurement error [%FS]	Span Accuracy [%FS]	Effective Resolution [PaRMS]	Packing	Status
Gage Pressure Sensor	MMR902A34A	7 x 7 x 7.2	-1,000 ~ 40,000	40,000	2.3	0.66	0.7	Tray	MP
	MMR902A34ABE	7 x 7 x 7.2	-1,000 ~ 40,000	40,000	2.3	0.66	0.7	Taping (B)	Developing
	MMR902A34ARE	7 x 7 x 7.2	-1,000 ~ 40,000	40,000	2.3	0.66	0.7	Taping (R)	Developing
	MMR906XAN	6 x 5 x 7.2	-1,000 ~ 40,000	40,000	-	0.66	1.0	Tray	MP
	MMR906XARE	6 x 5 x 7.2	-1,000 ~ 40,000	40,000	-	0.66	1.0	Taping (R)	Developing
	MMR920C02A	7 x 7 x 7.2	-1,961 ~ 1,961	1,961	2.0	1.30	0.2	Tray	Planning
	MMR920C02ARE	7 x 7 x 7.2	-1,961 ~ 1,961	1,961	2.0	1.30	0.2	Taping (R)	Planning
	MMR920C04A	7 x 7 x 7.2	-3,922 ~ 3,922	3,922	1.0	0.65	0.2	Tray	Developing
	MMR920C04ARE	7 x 7 x 7.2	-3,922 ~ 3,922	3,922	1.0	0.65	0.2	Taping (R)	Developing
	MMR920C07A	7 x 7 x 7.2	-6,865 ~ 6,865	6,865	1.0	0.65	0.2	Tray	Planning
	MMR920C07ARE	7 x 7 x 7.2	-6,865 ~ 6,865	6,865	1.0	0.65	0.2	Taping (R)	Planning
	MMR920C10A	7 x 7 x 7.2	-9,807 ~ 9,807	9,807	1.0	0.65	0.2	Tray	Planning
	MMR920C10ARE	7 x 7 x 7.2	-9,807 ~ 9,807	9,807	1.0	0.65	0.2	Taping (R)	Planning
Differential Pressure Sensor	MMR940C02A	29 x 18 x 14.25	-1,961 ~ 1,961	1,961	(2.0)	1.30	0.2	Tray	Planning
	MMR940C04A	29 x 18 x 14.25	-3,922 ~ 3,922	3,922	(1.0)	0.65	0.2	Tray	Developing
	MMR940C07A	29 x 18 x 14.25	-6,865 ~ 6,865	6,865	(1.0)	0.65	0.2	Tray	Planning
	MMR940C10A	29 x 18 x 14.25	-9,807 ~ 9,807	9,807	(1.0)	0.65	0.2	Tray	Planning

## NOTES

## Safety Precautions

- Though Mitsumi Electric Co., Ltd. (hereinafter referred to as "Mitsumi") works continually to improve our product's quality and reliability, semiconductor products may generally malfunction or fail. Customers are responsible for complying with safety standards and for providing adequate designs and safeguards for their hardware, software and systems which minimize risk and avoid situations in which a malfunction or failure of this product could cause loss of human life, bodily injury, or damage to property, including data loss or corruption. Before customers use this product, create designs including this product, or incorporate this product into their own applications, customers must also refer to and comply with (a) the latest versions or all of our relevant information, including without limitation, product specifications, data sheets and application notes for this product and (b) the user's manual, handling instructions or all relevant information for any products which is to be used, or combined with this products. Customers are solely responsible for all aspects of their own product design or applications, including but not limited to (a) determining the appropriateness of the use of this product in such design or applications; (b) evaluating and determining the applicability of any information contained in this document, or in charts, diagrams, programs, algorithms, sample application circuits, or any other referenced documents; and (c) validating all operating parameters for such designs and applications. Mitsumi assumes no liability for customers' product design or applications.
- This product is intended for applying to computers, OA units, communication units, instrumentation units, machine tools, industrial robots, AV units, household electrical appliances, and other general electronic units.
- If you have any intentions to apply this product to the units related to the control and safety of transportation units (vehicles, trains, etc.), traffic signaling units, disaster-preventive & burglar-proof units, or the like, contact our sales representatives in advance.
- Don't apply this product to any aeronautical & space systems, submarine repeaters, nuclear power controllers, medical units involving the human life, or the like.
- Before using this product, even when it is not used for the usage written above, notify and present us beforehand if special care and attention are needed for its application, intended purpose, environment of usage, risk, and the design or inspection specification corresponding to them.
- If any damage to our customer is objectively identified to be caused by the defect of this product, Mitsumi is responsible for it. In this case, Mitsumi is liable for the cost limited to the delivery price of this product.

## Application considerations during actual circuit design

- The outline of parameters described herein has been chosen as an explanation of the standard parameters and performance of the product. When you actually plan to use the product, please ensure that the outside conditions are reflected in the actual circuit and assembling designs.
- Before using this product, please evaluate and confirm the actual application with this product mounted and embedded.
- To investigate the influence by applied transient load or external noise, It is necessary to evaluate and confirm them with mounting this product to the actual application.
- Any usage above the maximum rating may destroy this product or shorten the lifetime. Be sure to use this product under the maximum rating.
- If you continue to use this product highly-loaded (applying high temperature, large current or high voltage; or variation of temperature) even under the absolute maximum rating and even in the operating range, the reliability of this product may decrease significantly. Please design appropriate reliability in consideration of power dissipation and voltage corresponding to the temperature and designed lifetime after confirming our individual reliability documents (such as reliability test report or estimated failure rate). It is recommended that, before using this product, you appropriately derate the maximum power dissipation (typically, 80% or less of the maximum value) considering parameters including ambient temperature, input voltage, and output current.

## Precautions for Foreign Exchange and Foreign Trade Control Act

- If you export or take products and technologies in this document which are subject to security trade control based on the Foreign Exchange and Foreign Trade Act to overseas from Japan, permission of the Japanese government is required.

## Prohibitions for Industrial Property Rights

- Since this document contains the contents related to our copyright and know-how, you are requested not to use this document for any purpose other than the application of this product.
- If a use of this product causes a dispute related to the industrial property rights of a third party, Mitsumi has no liability for any disputes except those which arise directly from the manufacturing and manufacturing method of our products.

## Precautions for Product Liability Act

- No responsibility is assumed by us for any consequence resulting from any wrong or improper use or operation, etc. of this product.

## Others

- Any part of the contents contained herein must not be reprinted or reproduced without our prior permission.
- In case of any question arises out of the description in this specification, it shall be settled by the consultation between both parties promptly.

**ATTENTION**

- This product is designed and manufactured with the intention of normal use in general electronics. No special circumstance as described below is considered for the use of it when it is designed. With this reason, any use and storage under the circumstances below may affect the performance of this product. Prior confirmation of performance and reliability is requested to customers.
  - Environment with strong static electricity or electromagnetic wave
  - Environment with high temperature or high humidity where dew condensation may occur
- This product is not designed to withstand radioactivity, and must avoid using in a radioactive environment.

**ADDDITIONAL NOTES**

- The pressure medium which can use directly is only air. Please do not use other media, especially corrosive gases (organic solvent gas, sulfurous acid gas, hydrogen sulfide gas, etc.) and media which include moisture and foreign substance, since they could cause damages or malfunctions.
- Please handle it noting the foreign body mixing with the pressure opening and atmospheric pressure opening after opening packing.
- When cut folding the PCB after mounting this product, take measures to prevent stress to the package. Also, when you insert the tube in this product, please note that plugging it vertically. Load in the lateral direction of the cover of the nozzle is up to 1kg or less. (Load condition: position of height 4mm from the marking surface.) Excessive load could cause damages of cover, or air leak by peeling from the interface of the cover and the substrate, or malfunctions.
- The light that enters from the pressure entrance reaches the semiconductor chip. Please avoid use in the environment that light enters into the pressure entrance directly, because the semiconductor chip might malfunction because of light.

MARKING CONTENTS

①~②	Model name			
	2A			
③	Production year			
④	Production month			
	month	marking	month	marking
	January	1	July	7
	February	2	August	8
	March	3	September	9
	April	4	October	J
	May	5	November	K
	June	6	December	L
⑤	Production day			
	day	marking	day	marking
	1	1	16	G
	2	2	17	H
	3	3	18	J
	4	4	19	K
	5	5	20	L
	6	6	21	M
	7	7	22	N
	8	8	23	P
	9	9	24	R
	10	A	25	S
	11	B	26	T
	12	C	27	U
	13	D	28	V
	14	E	29	W
	15	F	30	X
		31	Y	
⑥~⑦	Rank			
	Typ. Supply voltage		marking	
	3.4V		34	

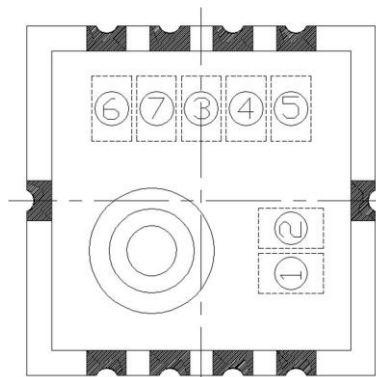



**PACKING SPECIFICATIONS (TRAY)**

QUANTITY

- VACUUM PACKING 700 pcs / SHIELD BAG
- BOX PACKING MAX 5,600 pcs / BOX (8BAGS)

THE QUANTITY IS FILLED IN THE PACKING SLIP

PACKING SPECIFICATIONS

- TRAY STORAGE SPECIFICATION

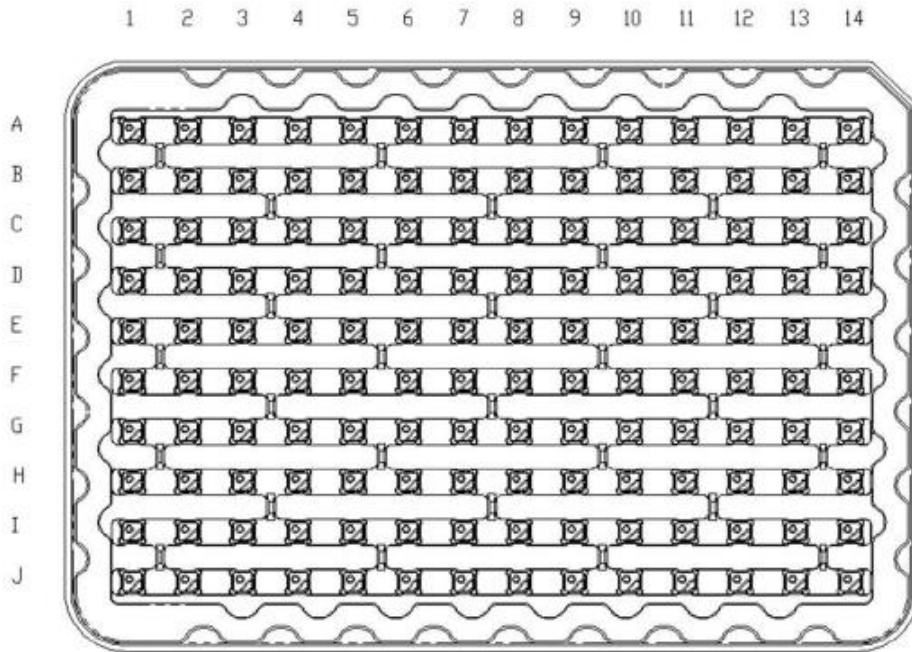

1. PRODUCTION STORAGE DIRECTION

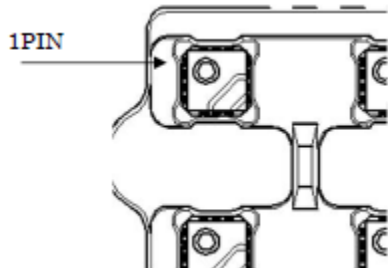

2. BROKEN NUMBER PRODUCTION STORAGE

REGARDING BROKEN NUMBER PRODUCTION STORAGE ,  
IT IS HOUSED IN FOLLOWING-ORDER.  
(A1、B1、...、I1、J1)、(A2、B2、...、I2、J2)、...、(A14、B14、...、I14、J14) .

3. TRAY MATERIAL, DISPOSED ELECTRICATION PREVENTION.

- TRAY DIMENSION

TRAY A

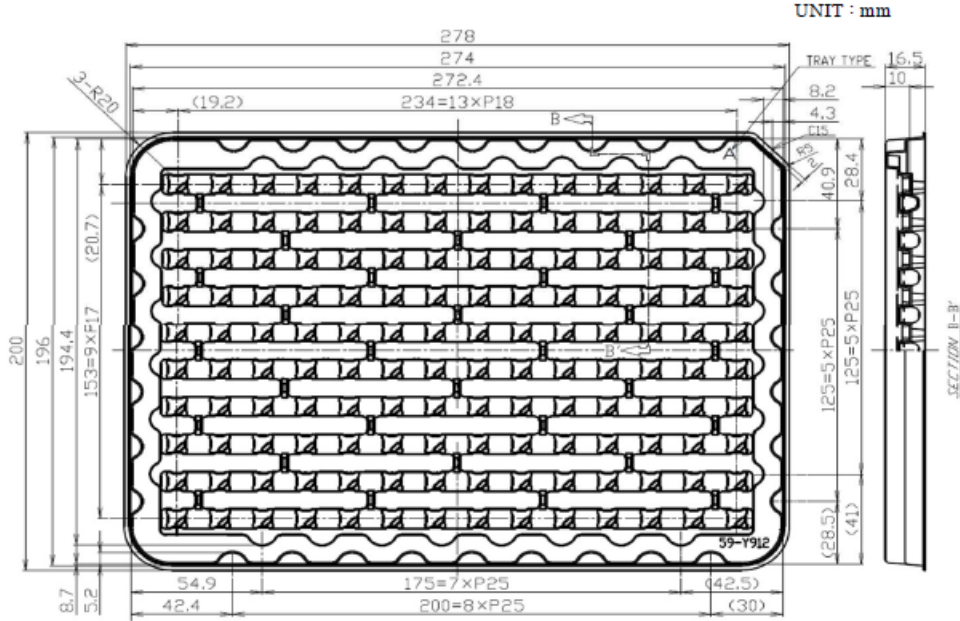

TRAY B

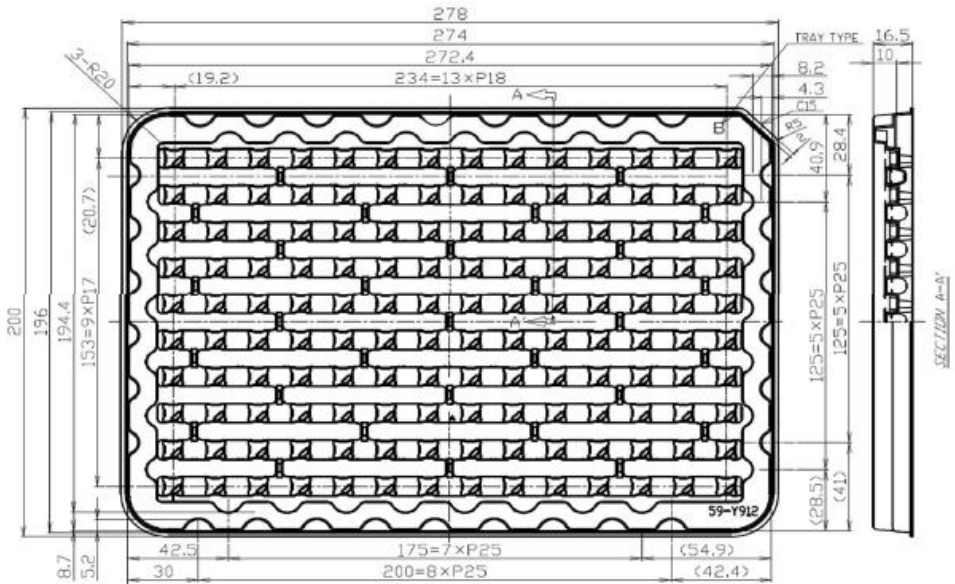

The contents of this document are subject to change without notice.

©2022 Mitsumi co., Ltd. All rights reserved.

MITSUMI ELECTRIC CO., LTD. Semiconductor Div.

<https://product.minebeamitsumi.com/en/>

- PACKING SPECIFICATION

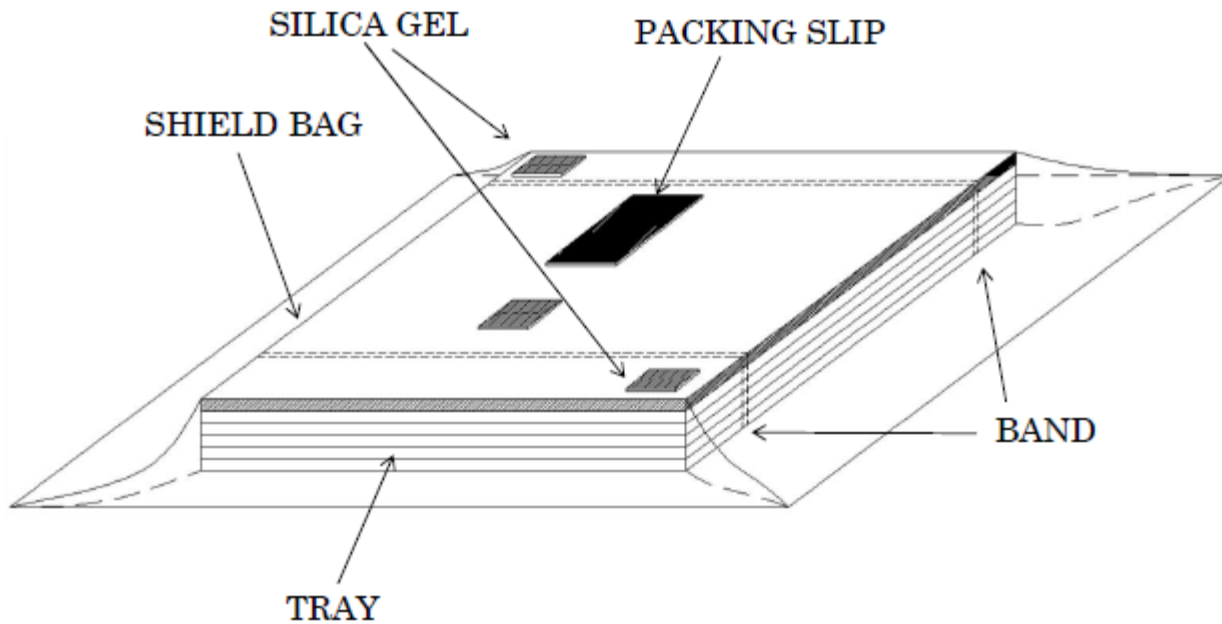

THESE 6 TRAYS WHICH ARE 5 TRAYS WITH PRODUCTS AND EMPTY TRAY AS LID ARE PILED UP. ALSO, THESE TRAYS ARE FIXED BY BAND. THESE ARE VACUUM-HEAT-SEALED TOGETHER WITH THE SILICA GEL.  
 ※THIS TRAY HAS TYPE A AND TYPE B. THEY ARE PILED UP ALTERNATELY.  
 (IT IS POSSIBLE TO USE BOTH TYPE TRAYS AS EMPTY ONE.)

## · BOX DIMENSION

UNIT : mm

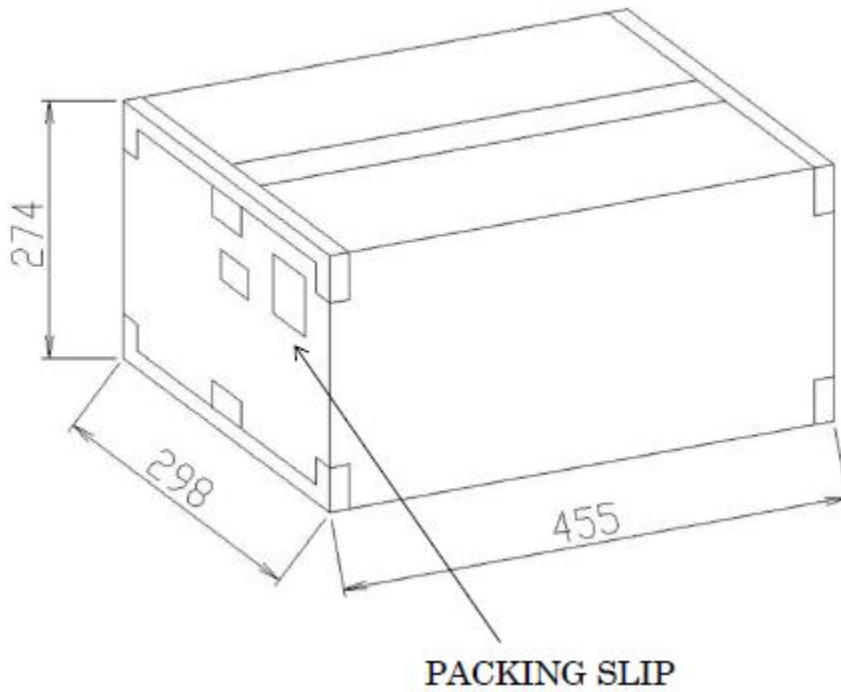

PUT MAX 8 BAGS IN THE CARTON BOX.  
AFTER PACKING BY TAPE (5,600 PCS MAX)  
PUT THE PACKING SLIP ON THE SIDE OF THE CARTON BOX.

PACKING SLIP SPECIFICATION

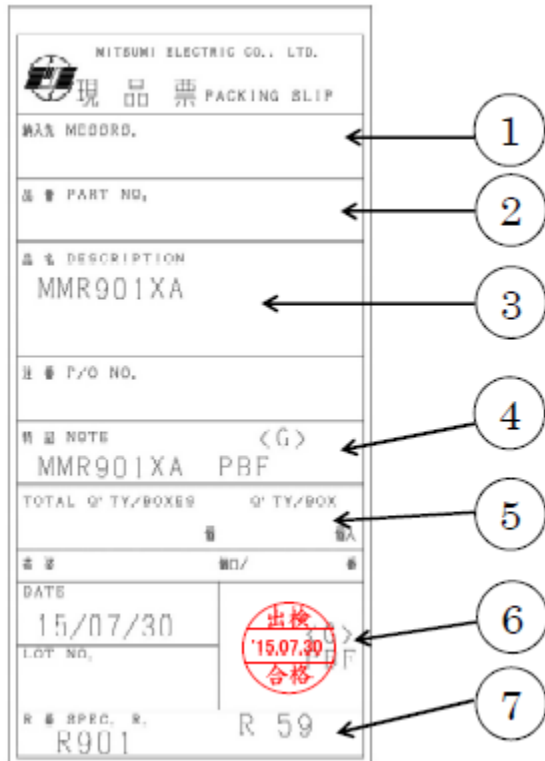

- ① CUSTOMER NAME
- ② CUSTOMER'S MODEL NAME
- ③ MITSUMI MODEL NAME
- ④ "G mark" meaning is RoHS-compliant.
- ⑤ PACKING Q'TY (PACK/CARTON)
- ⑥ QC STAMP(SHIPMENT DATE)  
※This is pass-stamp about shipment inspection.
- ⑦ MITSUMI DRAWING NUMBER

MARK LOT NUMBER

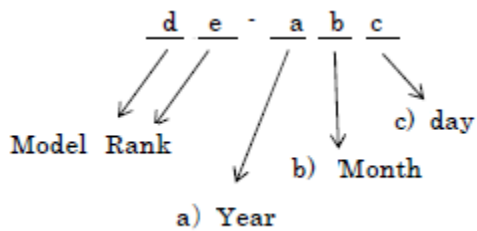

a)	Production year			
b)	Production month			
	month	marking	month	marking
	JAN	1	JUL	7
	FEB	2	AUG	8
	MAR	3	SEP	9
	APR	4	OCT	J
	MAY	5	NOV	K
	JUN	6	DEC	L
c)	Production day			
	day	marking	day	marking
	1	1	16	G
	2	2	17	H
	3	3	18	J
	4	4	19	K
	5	5	20	L
	6	6	21	M
	7	7	22	N
	8	8	23	P
	9	9	24	R
	10	A	25	S
	11	B	26	T
	12	C	27	U
	13	D	28	V
	14	E	29	W
	15	F	30	X
		31	Y	

**PACKING SPECIFICATIONS (TAPING, B HOUSING, R HOUSING)**

QUANTITY

- REEK PACKING 700 pcs/REEL
- BOX PACKING MAX 700 pcs /BOX (1REEL)

THE QUANTITY IS FILLED IN THE PACKING SLIP

PACKING SPECIFICATIONS

- B HOUSING SPECIFICATION

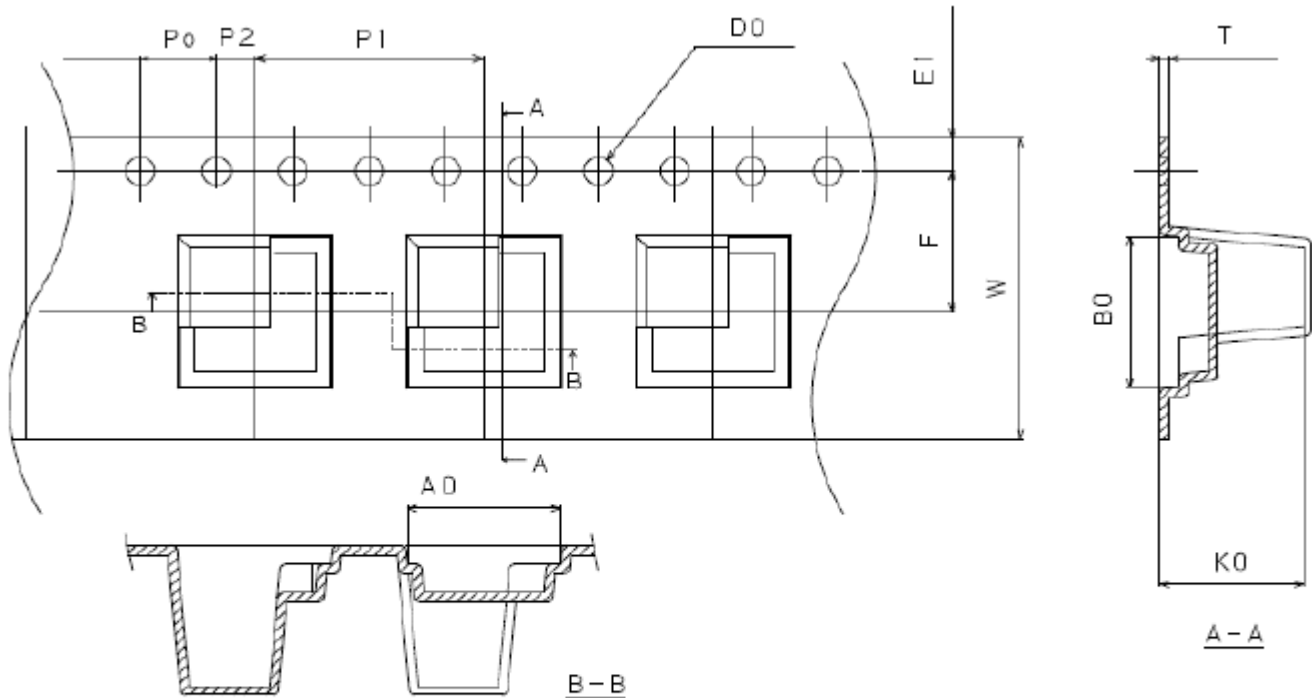

SYM.	A0	B0	W	F	E1	P1	P2	P0	φD0	T	K0
UNIT	8.0	8.0	16.0	7.5	1.75	12.0	2.0	4.0	1.5	0.5	7.5
mm	±0.1	±0.1	+0.3 -0.1	±0.1	±0.1	±0.1	±0.1	±0.1	+0.1 -0.0	±0.05	±0.1

## 1. PRODUCTION STORAGE DIRECTION

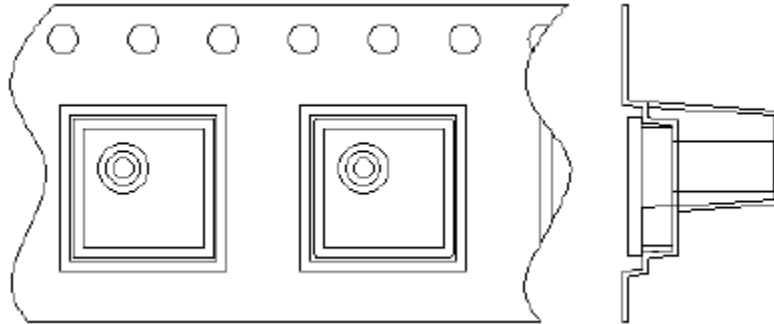
**B HOUSING**

2. CARRIER TAPE MATERIEL : DISPOSED ELECTRICATION PREVENTION.
3. THE LENGTH OF LEADER TAPE : MORE THAN 100 mm INCLUDING 9 OR MORE EMBOSES IN WHICH NO COMPONENT IS PLACED.
4. THE LENGTH OF TRAILER TAPE : MORE THAN 160 mm INCLUDING EMBOSES IN WHICH NO COMPONENT IS PLACED.

R HOUSING SPECIFICATION

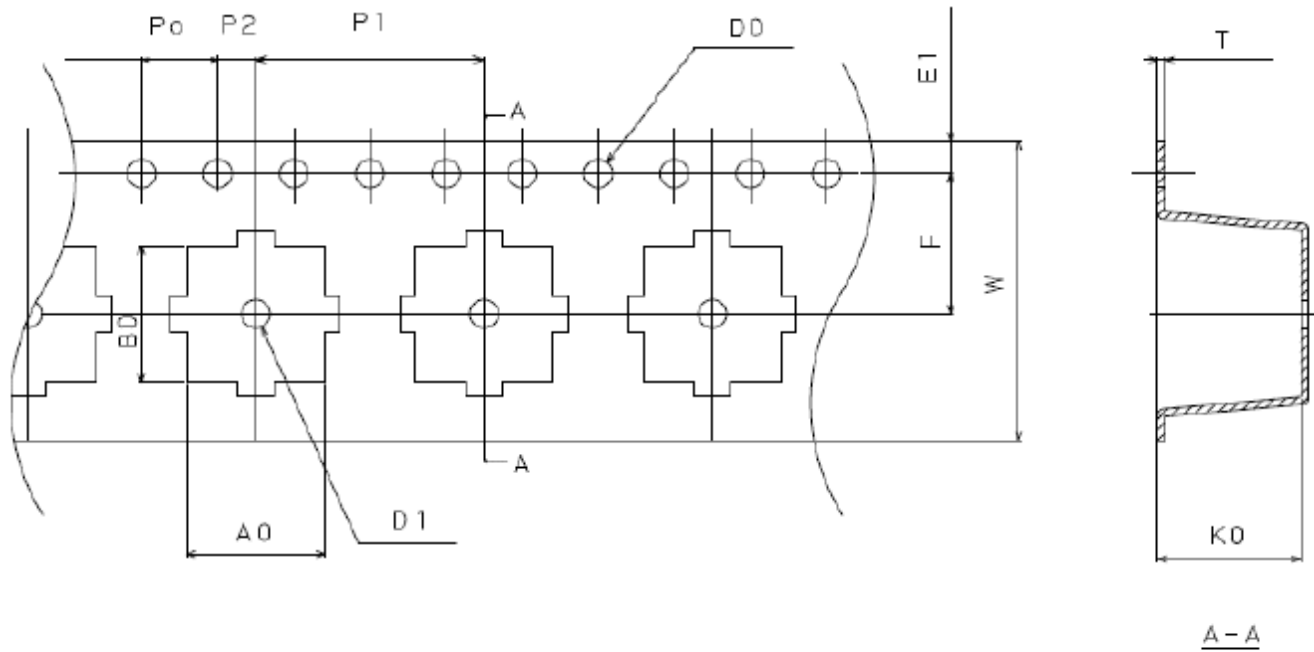

SYM.	A0	B0	W	F	E1	P1	P2	P0	$\phi$ D0	T	K0	$\phi$ D1
UNIT	7.3	7.3	16.0	7.5	1.75	12.0	2.0	4.0	1.5	0.4	7.5	1.5
mm	$\pm 0.1$	$\pm 0.1$	$^{+0.3}_{-0.1}$	$\pm 0.1$	$\pm 0.1$	$\pm 0.1$	$\pm 0.1$	$\pm 0.1$	$^{+0.1}_{-0.0}$	$\pm 0.05$	$\pm 0.1$	$\pm 0.1$



## 1. PRODUCTION STORAGE DIRECTION

R HOUSING

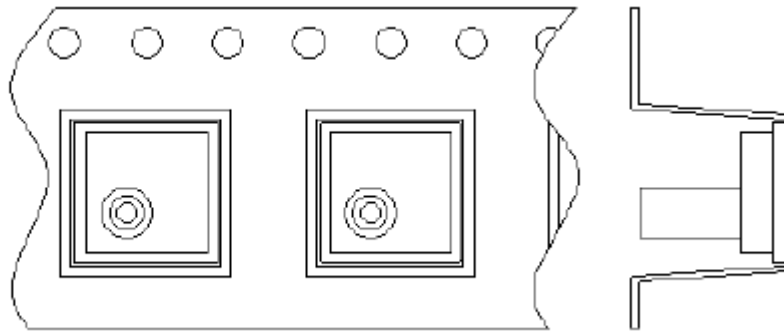

2. CARRIER TAPE MATERIEL : DISPOSED ELECTRICATION PREVENTION.
3. THE LENGTH OF LEADER TAPE : MORE THAN 100 mm INCLUDING 9 OR MORE EMBOSES IN WHICH NO COMPONENT IS PLACED.
4. THE LENGTH OF TRAILER TAPE : MORE THAN 160 mm INCLUDING EMBOSES IN WHICH NO COMPONENT IS PLACED.

REEL DIMENSION

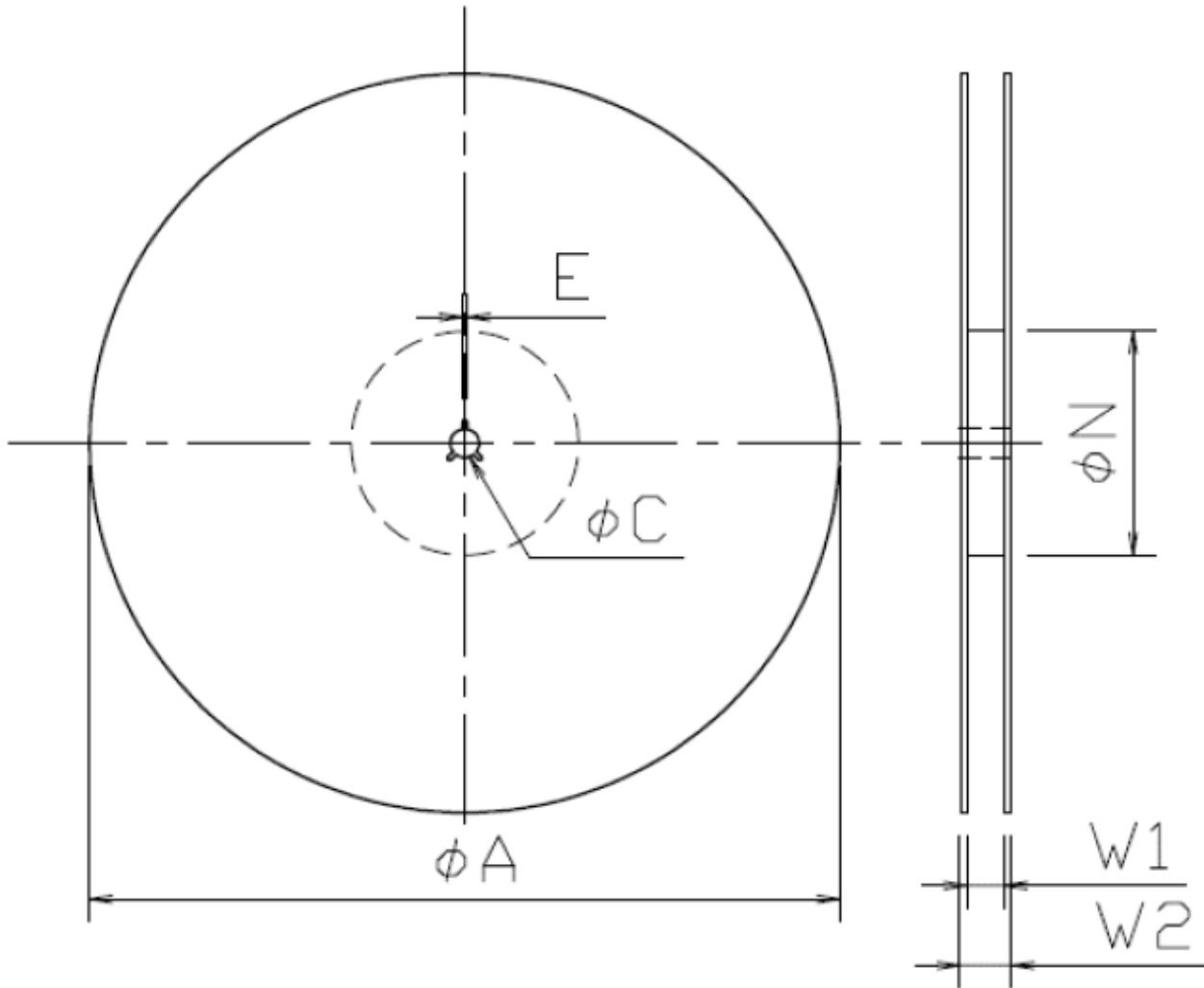

記号 SYM.	$\phi A$	$\phi C$	$\phi N$	E	W1	W2
UNIT	330	13.0	100	2.0	17.4	21.4
mm	$\pm 2.0$	$\pm 0.2$	$\pm 1.0$	$\pm 0.5$	$\pm 1.0$	$\pm 1.0$

MOISTURE PROOF PACKING

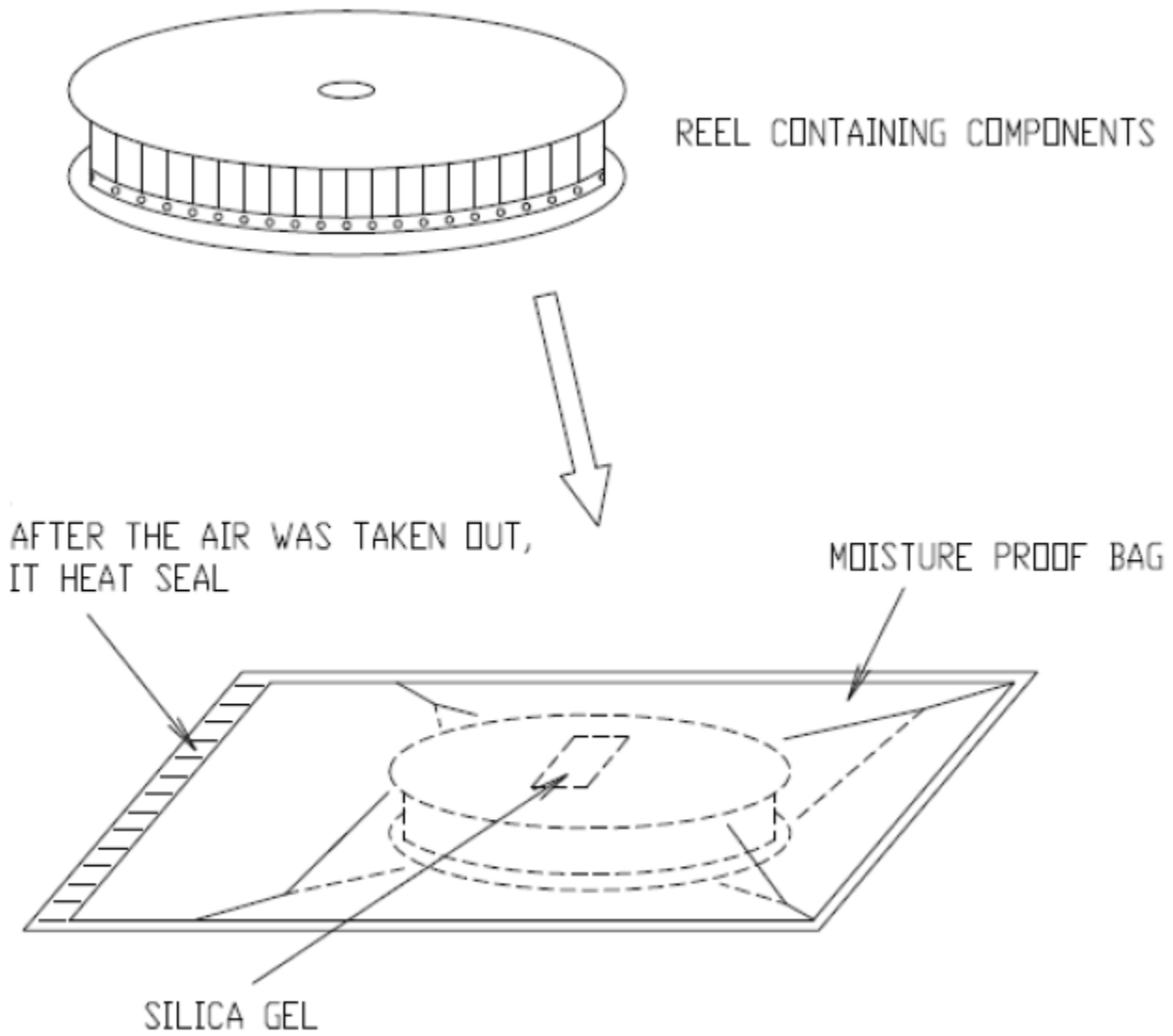

· BOX DIMENSION

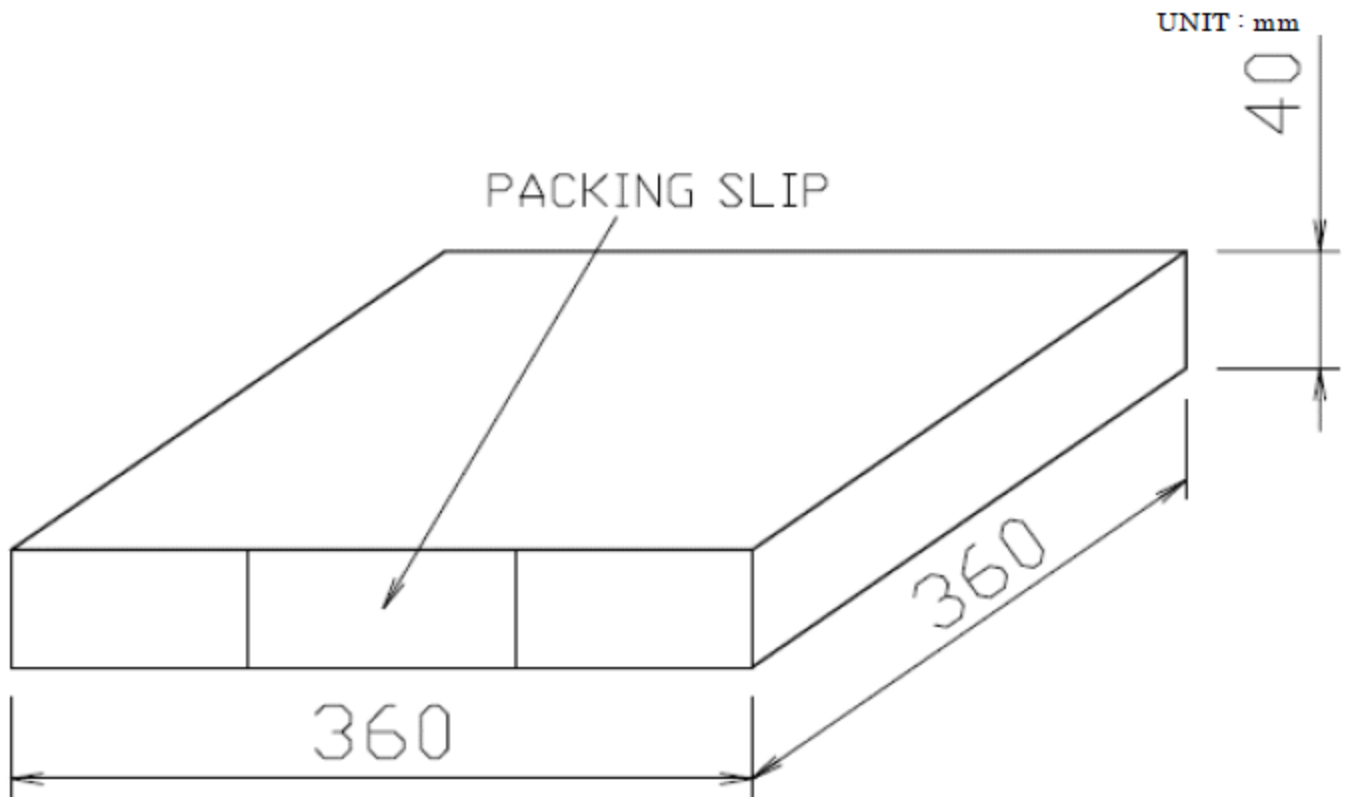

PACKING SLIP SPECIFICATION

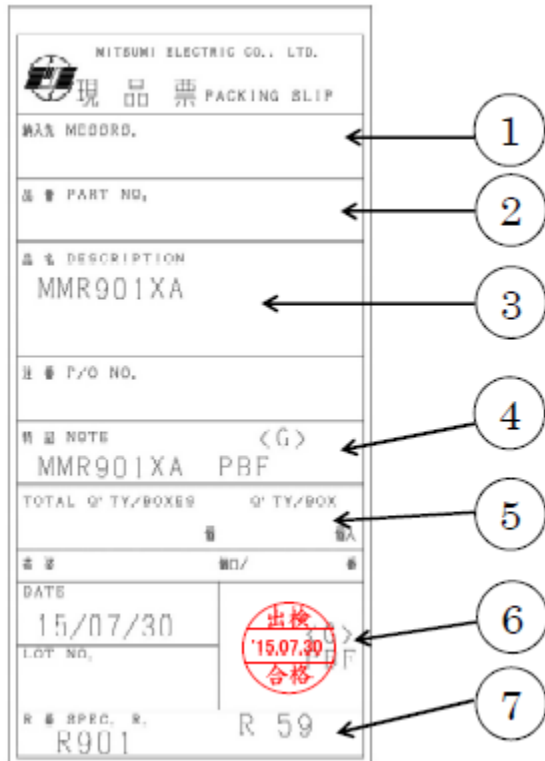

- ① CUSTOMER NAME
- ② CUSTOMER'S MODEL NAME
- ③ MITSUMI MODEL NAME
- ④ "G mark" meaning is RoHS-compliant.
- ⑤ PACKING Q'TY (PACK/CARTON)
- ⑥ QC STAMP(SHIPMENT DATE)  
※This is pass-stamp about shipment inspection.
- ⑦ MITSUMI DRAWING NUMBER

MARK LOT NUMBER

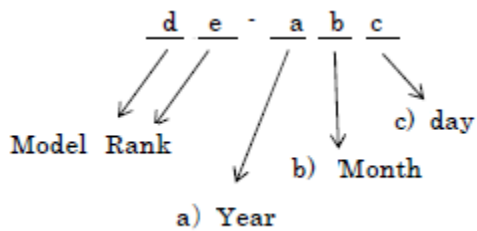

a)	Production year			
b)	Production month			
	month	marking	month	marking
	JAN	1	JUL	7
	FEB	2	AUG	8
	MAR	3	SEP	9
	APR	4	OCT	J
	MAY	5	NOV	K
	JUN	6	DEC	L
c)	Production day			
	day	marking	day	marking
	1	1	16	G
	2	2	17	H
	3	3	18	J
	4	4	19	K
	5	5	20	L
	6	6	21	M
	7	7	22	N
	8	8	23	P
	9	9	24	R
	10	A	25	S
	11	B	26	T
	12	C	27	U
	13	D	28	V
	14	E	29	W
15	F	30	X	
		31	Y	

RECOMMENDED LAND PATTERN

UNIT	mm
------	----

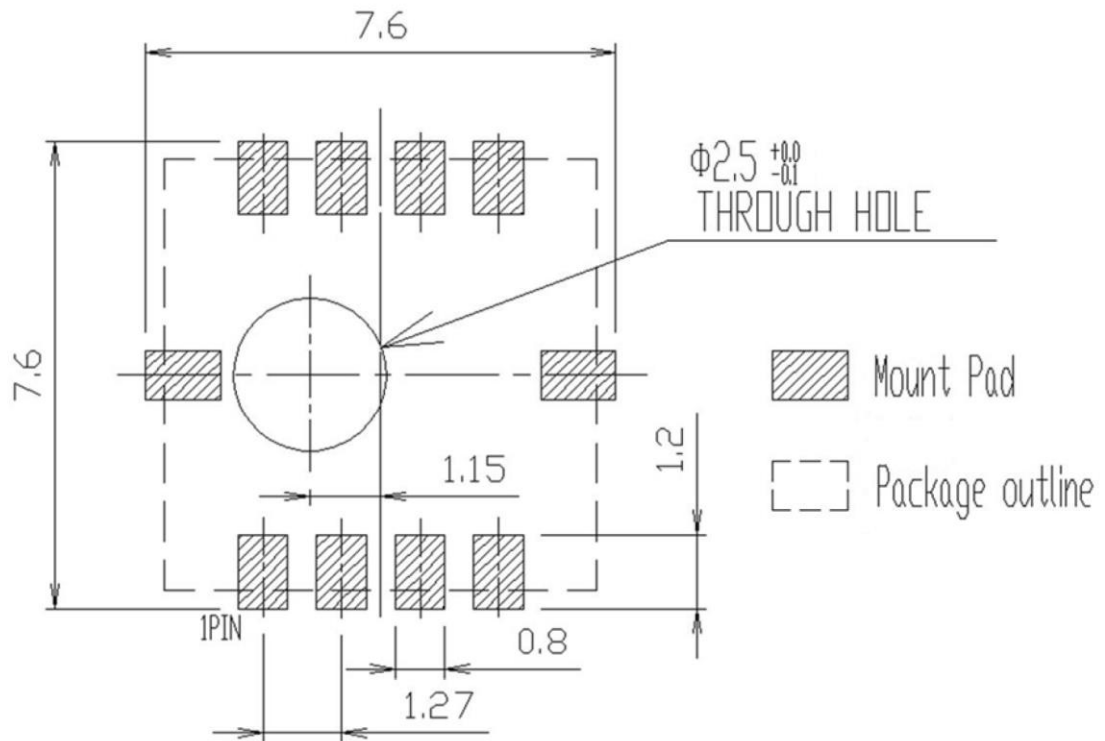

The dimension are for reference only and not guaranteed by design.

To design practically, correction should be made for optimized dimensions considering the effects of the board type to be mounted, mount (soldering) method, type and coating thickness of cream solder.

CONDITION FOR PACKAGE MOUNTING

Pb-Free recommended profile condition

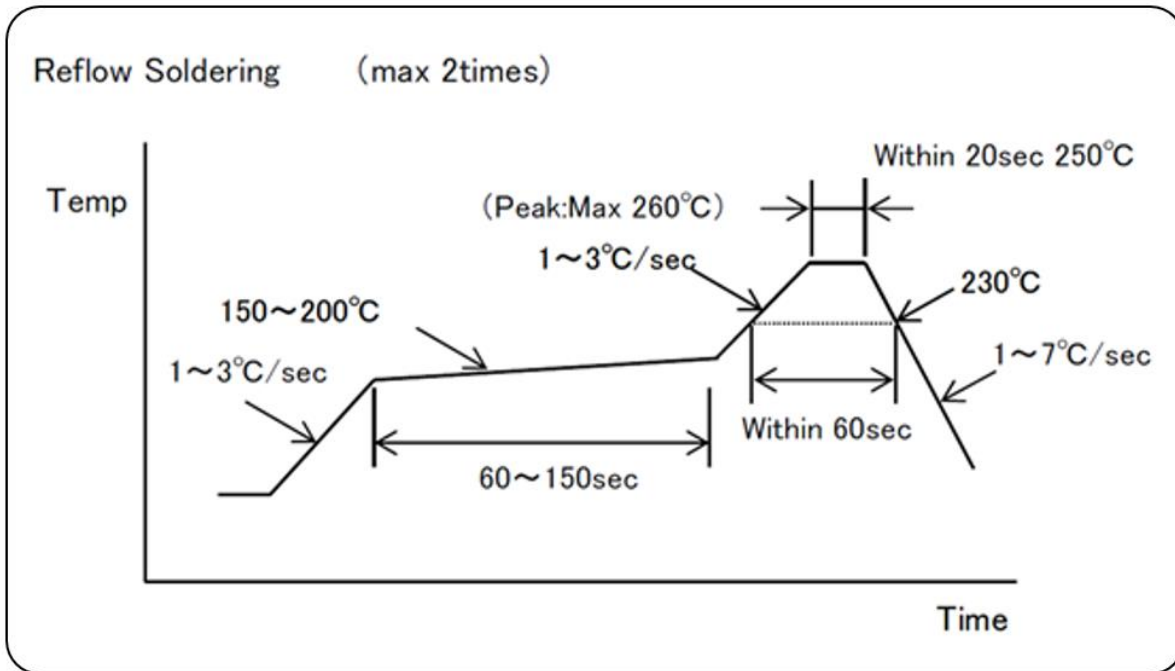

This profile gives recommended values, which are not guaranteed. For mounting the package, evaluate the profile with the equipment, conditions, and materials to be used.

- \*Mounting by flow soldering  
Flow soldering cannot be used for mounting of this package.
- \*Mounting by manual soldering  
Manual soldering cannot be used for mounting of this package.

In the case of cleaning, please use cotton swab, and also please keep soldering-solution from entering into the pressure and atmospheric pressure opening. Please do not use ultrasonic cleaning (dipping).

Cleaning method

Cleaning solution	Isopropyl alcohol
Solvent temperature	Max 45°C
Cleaning time	Within 3 min

Note

When insert a tube to this package, please keep direction of a tube at right angle with this package. Also, after mounting by reflow, please make sure not to insert a tube to package before finish cooling. If place an extra strain on cover nozzle, it is possible that occur cover nozzle broken, interface delamination between cover nozzle and printed wiring board. It has the potential to become air-leak problem.

#### Storage method

##### Storage condition

Store the device under the following conditions.

Temperature: 5~30°C

Humidity: 40~70%RH

Storage life: 1year

For the product in the moisture-proof packaging, follow these conditions after unpacking.

Temperature: 5~30°C

Humidity: 40~70%RH

Storage life: 168hours

Do not store this device where a large amount of dust or harmful volatile gas exists, electrostatic is easily charged, condensation is generated, or changes in temperature and humidity are wide, or under the direct sunlight.

#### Baking

If the storage time specified above has passed, mounting by soldering may cause cracks on the moisture absorbed package. Before mounting, the package should be baked under the following conditions.

Temperature: 125°C

Treating time: 16 to 24 hours

Tray is not heat-resistant type.

Before baking, the device should be placed in a heat-resistant container.

In consideration of the time-consuming baking process and the possibility of deformed terminal, the device should be mounted promptly within the time observing the storage conditions.

If a long-term storage is needed, a desiccator or a dry box should be used.

#### Handling instructions

Shipping boxes must be handled with care because any drop or shock may damage the device.

Additionally, the device must be handled in the place with the protection against electrostatic charge and without extreme changes of temperature/humidity.



## MITSUMI ELECTRIC CO.,LTD.

Strategy Engineering Department Semiconductor Business Division

Tel: +81-46-230-3470 / <http://www.mitsumi.co.jp>

### Notes:

Any products mentioned this datasheet are subject to any modification in their appearance and others for improvements without prior notification. The details listed here are not a guarantee of the individual products at the time of ordering. When using the products, you will be asked to check their specifications.