



Click [here](#) to ask an associate for production status of specific part numbers.

## Evaluates: MAX96717F

## MAX96717 DPHY Evaluation Kit

### General Description

The MAX96717 DPHY evaluation kit (EV kit) provides a proven design to evaluate the MAX96717 high-bandwidth gigabit multimedia serial link (GMSL) serializer with spread spectrum and full-duplex control channel using a standard FAKRA coaxial (Coax) or HMTD cable. The EV kit also includes Windows® 7 and Windows® 10 software that provides a simple graphical user interface (GUI) for exercising features of the device. The EV kit comes with a MAX96717, MAX96717F, MAX96717K or MAX96717R IC installed.

For complete GMSL evaluation using a standard FAKRA coaxial cable or HMTD cable, order the MAX96717 Coax EV kit and a companion deserializer board (MAX96716 Coax EV kit referenced in this document).

**Note:** In the following sections, “serializer” refers to camera serializer interface (CSI) serializer, including MAX96717, MAX96717F, MAX96717K and MAX96717R. “Deserializer” refers to CSI deserializer MAX96716 and its variants.

This document applies to both Coax and HMTD evaluation kits. Coax cable is also referenced in this document.

### Benefits and Features

- Ability for Serializer to send GMSL data to Deserializer, converting it into MIPI CSI-2
- Windows 10 or Higher Compatible Software Support
- USB Controlled Interface (Cable Included)
- Powerful and Simple GUI for Comprehensive Device Feature Evaluation
- Board Powered by USB, 12V Wall Adapter or External Power Supply
- Proven PCB Layout
- Fully Assembled and Tested

**Note:** Coax EV kits are configured to use PoC and FAKRA connectors. For HMTD connector, order HMTD specific EV kits found in the Ordering Information section.

[Ordering Information](#) appears at end of data sheet.

### MAX96717 EV Kit Files

FILE	DESCRIPTION
MAXSerDesEV-GMSL_Vxxxx_Install.exe	Installs the EV kit software (GUI) onto Windows 10 or higher computers. Includes GUI user's guide, microcontroller firmware, and documentation.
MAXSerDesEV-GMSL.exe	GMSL graphical user interface (GUI) program

Windows is a registered trademark and registered service mark of Microsoft Corporation.

319-100949; Rev 2; 9/22

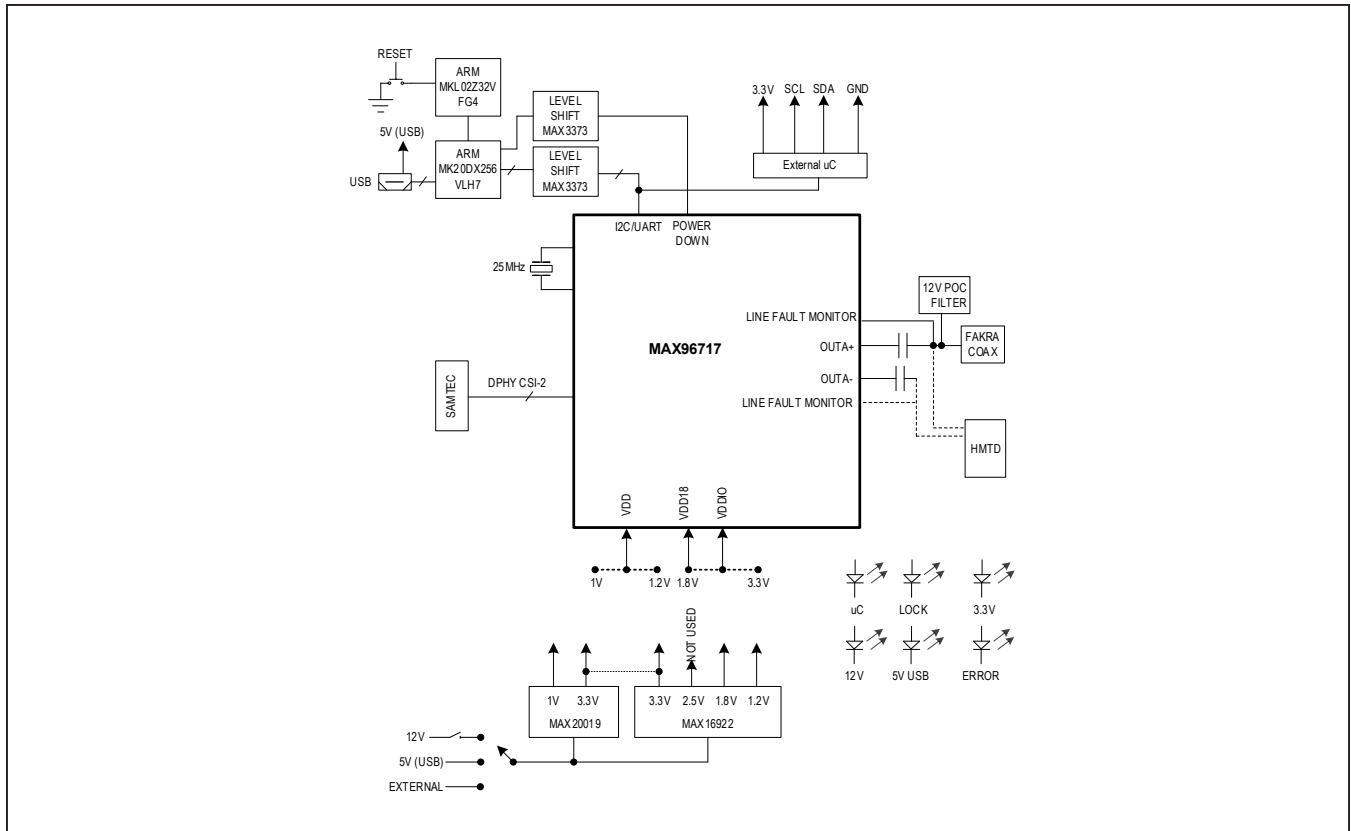

Figure 1. MAX96717 DPHY EV Kit Block Diagram

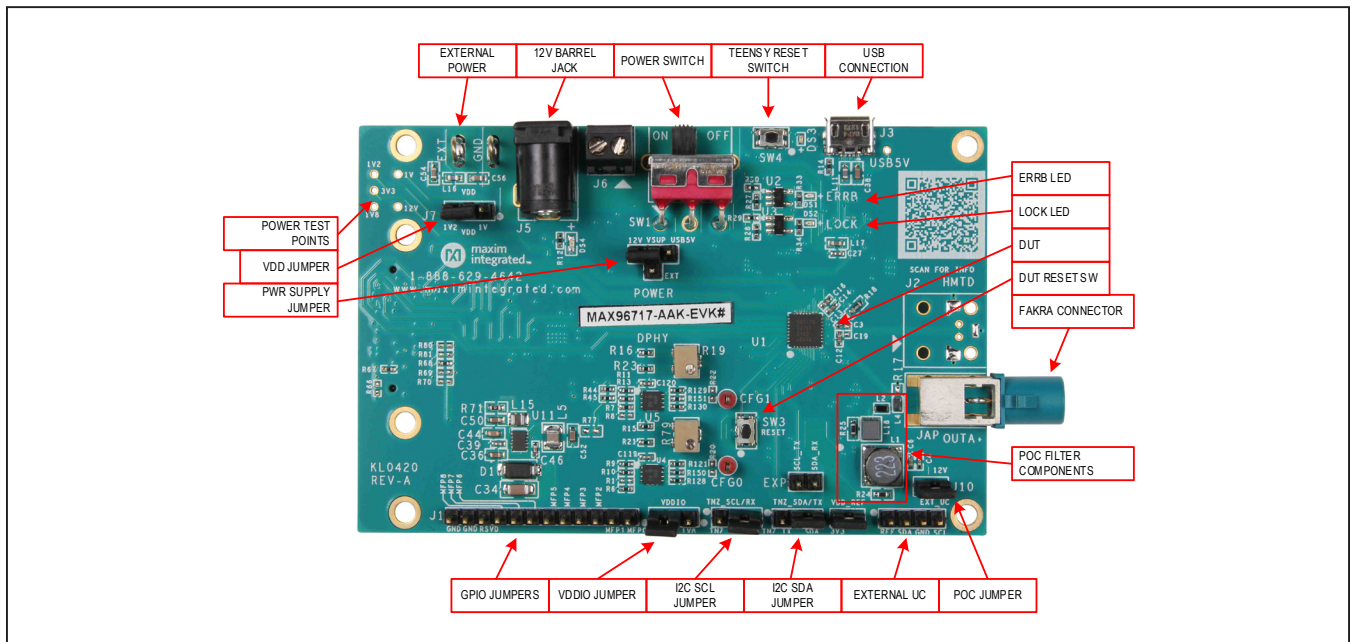

Figure 2. MAX96717 EV Kit Picture of Board (Top View)

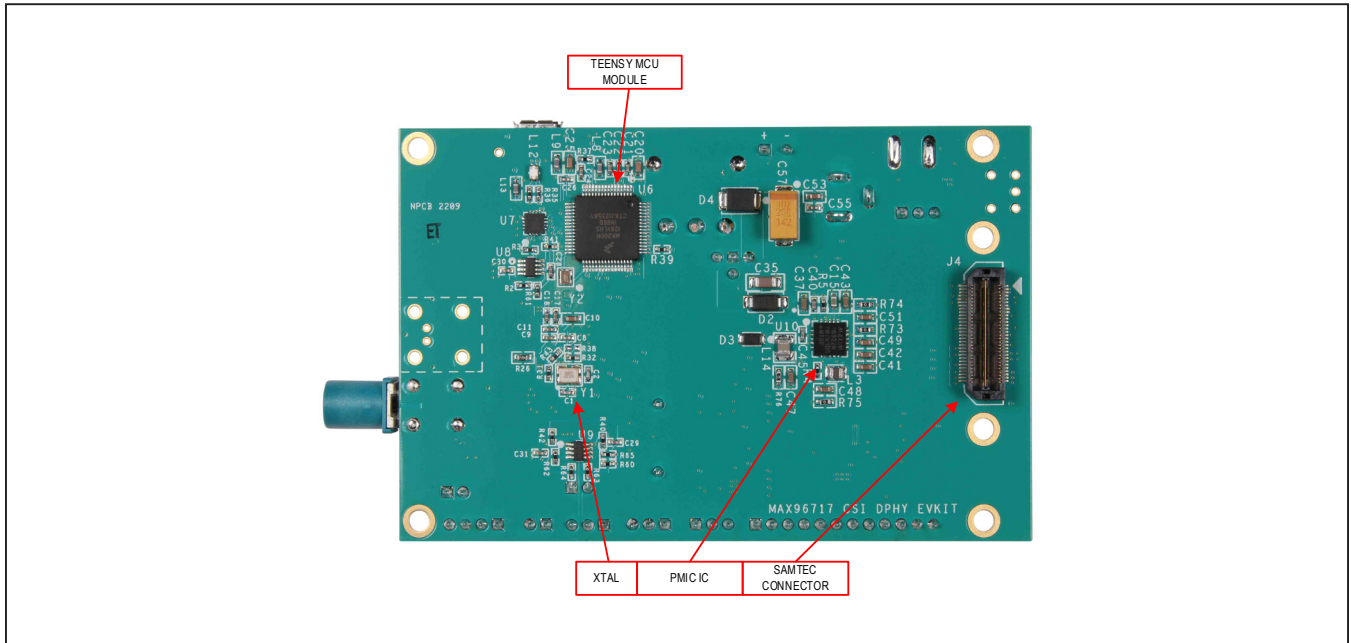

Figure 3. MAX96717 EV Kit Picture of Board (Bottom View)

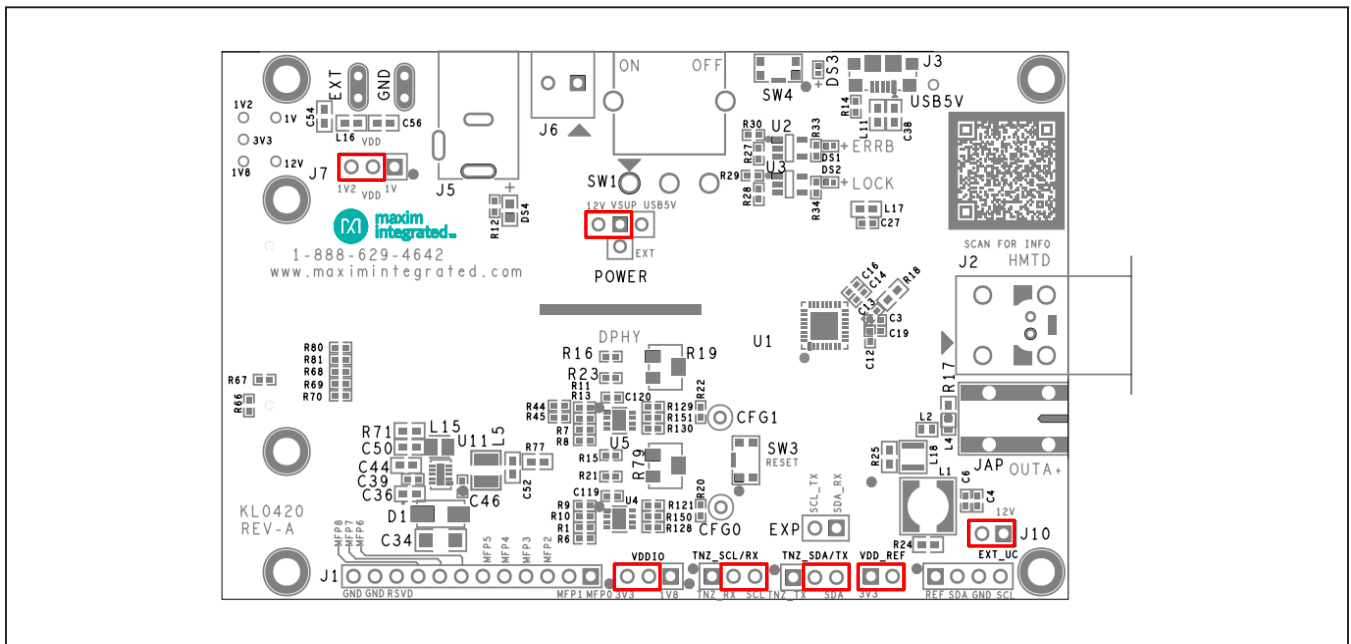

Figure 4. MAX96717 EV Kit Default Jumper

## Quick Start

This procedure applies to both Coax and HMTD EV kits. [Figure 5](#) shows a typical application that uses the CSI serializer with the CSI deserializer.

## Required Equipment

The following equipment is required to successfully use the MAX96717 DPHY EV kit in a serial link coax cable configuration:

- MAX96716 DPHY EV kit rev A
- FAKRA Cable Assembly
- PC with Windows 10 or higher and GMSL2 Software
- PC running GMSL Software
- Power supply source (500mA USB port, 5V/1A DC Supply or 12V barrel jack DC supply [provided])
- Micro-USB cable

## Procedure

- 1) Follow the steps below to verify board operation.
- 2) Download and install the latest GMSL EV kit software from [www.maximintegrated.com](http://www.maximintegrated.com) or contact Maxim Applications. Follow the GMSL GUI User's Guide instructions.
- 3) Verify that jumpers on the serializer board are in their default positions, as shown in [Figure 2](#), and SW1 is in the OFF position.
- 4) Verify that jumpers on the deserializer board are in their default positions, and SW1 is in the OFF position.
- 5) Set up the system as below:
  - Connect FAKRA cable from FAKRA PCB connector from serializer to deserializer (Link A or Link B).
  - Connect +12V wall power supply into the POWER connector.
- 6) Turn SW1 to the ON position on both serializer and deserializer EV kits.
- 7) Verify that all of the power LEDs and red Teensy LED are illuminated, indicating that the board is powered, and Teensy uC is powered on both serializer and deserializer.
- 8) Verify the LOCK LED on both serializer and deserializer EV kits are illuminated, indicating that the link is successfully established. If the LOCK\_LED is OFF or ERR\_LED is ON, refer to the [Troubleshooting](#) section.
- 9) Start the GMSL GUI software.
- 10) When the GUI opens, it automatically searches for any active listener in both I<sup>2</sup>C and UART mode and identifies a valid GMSL product. Once the serializer and deserializer are identified, they are shown as tabs in the GUI.
- 11) Read register 0x00 in both deserializer and serializer to ensure both devices are active.
- 12) Basic bring-up is complete. Refer to the GMSL GUI User's Guide, GMSL Bring-up Guide, the latest data-sheet, or contact Maxim Applications for additional details.

## Configuration (CFG) Pin Settings

The serializer's CFG pins use the pin voltage latched at power-up to configure the device. On-board I<sup>2</sup>C-configurable digital potentiometers or 0402 resistors set the configuration (CFG) pin voltage levels. By default, the board is wired to use the digital potentiometers.

The CFG states can be configured using the GMSL 2 GUI. Use the following GUI menu path: Tools > Set CFG Pin Levels.

To switch between using the digital potentiometer or resistor network to set CFG states, use 0Ω resistors to connect the CFG0/1 nets. The voltage on the CFG pins can be monitored on the CFG0 and CFG1 test points or on the 2x12 MFP header (J1).

If the serializer is not identified in the GUI, it is still possible to write to the CFG pins. For more information, refer to the [Troubleshooting](#) section.

The voltage levels scale with V<sub>DDIO</sub>. Tables 1-5 indicate the voltage levels necessary to configure the serializer for different modes of operation.

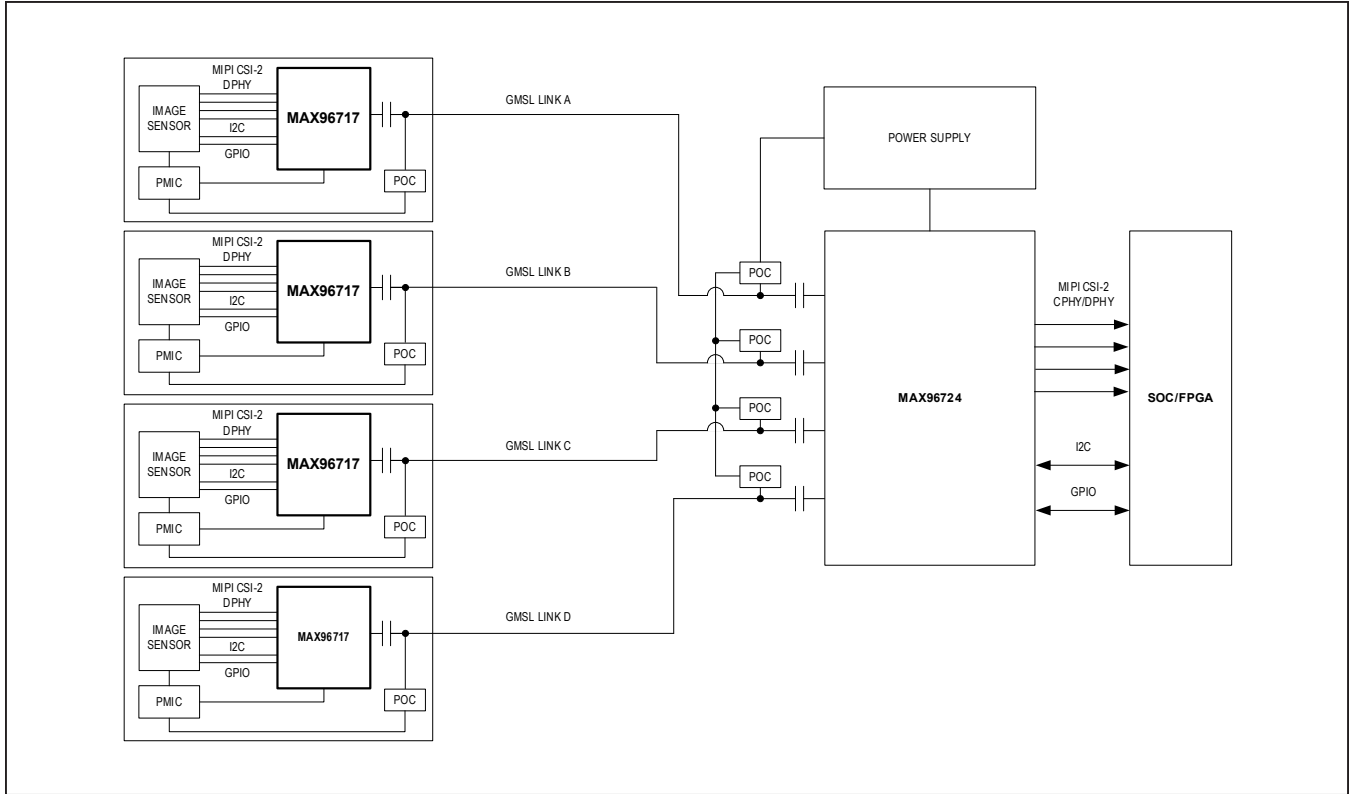

Figure 5. MAX96717 EV Kit Typical Block Diagram

Table 1 MAX96717/717F/717K CFG0 Pin Input Map

CFG0 INPUT VOLTAGE (PERCENT OF $V_{DDIO}$ )			SUGGESTED RESISTOR VALUES (1% TOLERANCE)		MAPPED CONFIGURATION		
MIN	TYP	MAX	R1 ( $\Omega$ )	R2 ( $\Omega$ )	I2CSEL	ROR/XTAL	DEVICE ADDRESS
0%	0%	11.7%	OPEN	10000	I2C	ROR	0x80
16.9%	20.2%	23.6%	80600	20500			0x84
28.8%	32.1%	35.5%	68100	32400		XTAL	0x80
40.7%	44.0%	47.4%	56200	44200			0x84
52.6%	56.0%	59.3%	44200	56200	UART	ROR	0x84
64.5%	67.9%	71.2%	32400	68100			0x80
76.4%	79.8%	83.1%	20500	80600		XTAL	0x84
88.3%	100%	100%	10000	OPEN			0x80

**Table 2. MAX96717R CFG0 Pin Input Map**

CFG0 INPUT VOLTAGE (PERCENT OF V <sub>DDIO</sub> )			SUGGESTED RESISTOR VALUES (1% TOLERANCE)		MAPPED CONFIGURATION
MIN	TYP	MAX	R1 (Ω)	R2 (Ω)	DEVICE ADDRESS
28.8%	32.1%	35.5%	68100	32400	0x80
40.7%	44.0%	47.4%	56200	44200	0x84

**Table 3. MAX96717/717K CFG1 Pin Input Map**

CFG1 INPUT VOLTAGE (PERCENT OF V <sub>DDIO</sub> )			SUGGESTED RESISTOR VALUES(1% TOLERANCE)		MAPPED CONFIGURATION (GMSL2 OPERATING MODE)		
MIN	TYP	MAX	R1 (Ω)	R2 (Ω)	CXTP	DATA RATE (GBPS)	TUNNEL/PIXEL MODE
0%	0%	11.7%	OPEN	10000	STP	3	Tunnel
16.9%	20.2%	23.6%	80600	20500		6	
28.8%	32.1%	35.5%	68100	32400		3	Pixel
40.7%	44.0%	47.4%	56200	44200		6	
52.6%	56.0%	59.3%	44200	56200	COAX	3	Tunnel
64.5%	67.9%	71.2%	32400	68100		6	
76.4%	79.8%	83.1%	20500	80600		3	Pixel
88.3%	100%	100%	10000	OPEN		6	

**Table 4. MAX96717F CFG1 Pin Input Map**

CFG1 INPUT VOLTAGE (PERCENT OF V <sub>DDIO</sub> )			SUGGESTED RESISTOR VALUES (1% TOLERANCE)		MAPPED CONFIGURATION (GMSL2 OPERATING MODE)		
MIN	TYP	MAX	R1 (Ω)	R2 (Ω)	CXTP	DATA RATE (GBPS)	TUNNEL/PIXEL MODE
0%	0%	11.7%	OPEN	10000	STP	3	Tunnel
16.9%	20.2%	23.6%	80600	20500		3	Pixel
28.8%	32.1%	35.5%	68100	32400		3	Pixel
40.7%	44.0%	47.4%	56200	44200		3	Pixel
52.6%	56.0%	59.3%	44200	56200	COAX	3	Tunnel
64.5%	67.9%	71.2%	32400	68100		3	Tunnel
76.4%	79.8%	83.1%	20500	80600		3	Pixel
88.3%	100%	100%	10000	OPEN		3	Pixel

Table 5. MAX96717R CFG1 Pin Input Map

CFG0 INPUT VOLTAGE (PERCENT OF $V_{DDIO}$ )			SUGGESTED RESISTOR VALUES (1% TOLERANCE)		MAPPED CONFIGURATION
MIN	TYP	MAX	R1 ( $\Omega$ )	R2 ( $\Omega$ )	TUNNEL/PIXEL MODE
52.6%	56.0%	59.3%	44200	56200	Tunnel
88.3%	100%	100%	10000	OPEN	Pixel

Table 6. Serializer Jumper Descriptions

The following table contains details of all the connectors, jumpers, and test points of the EV kit. The power configuration of the EV kit hardware can be reconfigured to allow external supply connections. [Figure 6](#) shows the power connection options.

JUMPER	SIGNAL	DEFAULT POSITION	FUNCTION
POWER	+12V, EXT PWR, 5V USB,	+12V	Power to supply voltage VSUP.
J1	MFP	Open	Connection for MFP signals.
J2	HMTD SIOA (+/-)	Open	HMTD connector for SIOA GMSL signal.
J3	USB Connection	Open	Connection from PC to TEENSY and +5V USB connection.
J4	SAMTEC Connector	Open	Connector for MIPI signals and MFP (SPI, I2C, GPIOs) signals.
J5	External 12V Input	N/A	12V DC input for board power.
J6	External Supply Input	Open	Header for GND connection and optional external voltage.
$V_{DDIO}$	$V_{DDIO}$ , 1.8V, 3.3V	3.3V	Connection between $V_{DDIO}$ , 1.8V and 3.3V.
$V_{DD}$	$V_{DD}$ , 1V, 1.2V	1.2V	Connection between $V_{DD}$ , 1V and 1.2V.
$V_{DD\_REF}$	$V_{DD\_REF}$	3.3V	Connection between $V_{DD\_REF}$ and 3.3V for I2C/UART lines.
RX_SDA	UART TX, I2C SDA	TNZ_SDA	Selection of I2C or UART connection to TEENSY.
TX_SCL	UART RX, I2C SCL	TNZ_SCL	Selection of I2C or UART connection to TEENSY.
EXP	SDA_RX, SCL_TX	Open	External I2C or UART connections.
EXT_UC	SDA, SCL, GND, $V_{DD\_REF}$	Open	External I2C or UART connections through the levels translator.
JAP	COAX SIOA+	Open	GMSL and PoC connection for COAX Link A.



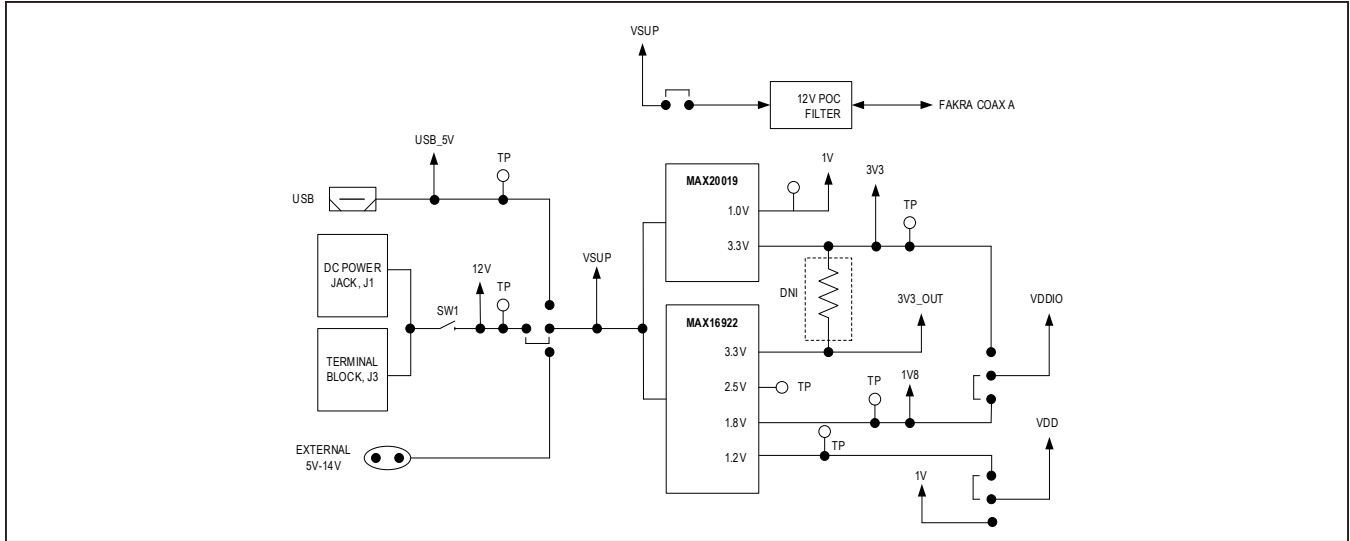

Figure 6. MAX96717 EV Kit Power Diagram

**Troubleshooting**

If the MAX96717 EV kit PCB fails to power-up or does not function properly, try the appropriate remedial actions below.

- 1) Verify the board’s red power switch (SW1) is set to the ON position.
- 2) Verify that the device is powered properly. Ensure that the voltages are within their operating ranges at all device pins. Verify that power LED is illuminated and/or measure voltage rail jumpers.
- 3) Check that all jumpers are correctly set. Refer to the default jumper settings table in the serializer and deserializer EV kit data sheets. Also, ensure that all jumpers are firmly attached. Replace loose or damaged jumpers, if necessary.
- 4) Check that the USB cable is properly seated in the USB port.
- 5) Check that the coax/STP cable connection between serializer and deserializer is properly secured.
- 6) Verify that the DUT has not been inadvertently put into Teensy reset mode. The board’s TEENSY\_RST button should only be pressed when firmware is being flashed to the DUT. If the button is pressed during normal operation, the device goes into Teensy reset mode. Power cycle the board to resume normal operation with the current firmware.
- 7) Validate that the correct CFG pin voltages are being used to configure the serializer. Check the method of biasing the CFG voltage at powerup. Measure the voltages at the pins. For details, refer to the [Configuration \(CFG\) Pin Settings](#) section.
- 8) If the CFG pin settings are incorrect, but the device is not identified in the GUI, proceed to the [Configuration \(CFG\) Pin Settings](#) section and set the desired CFG state values. Reset the part and verify if the GUI automatically identifies the device. If not, use the following menu path to locate the device: Options tab > Identify Devices. The low-level Commands tab can be monitored to see if I<sup>2</sup>C writes to the CFG pots are successful.
- 9) Check that the I<sup>2</sup>C/UART jumpers match the DUT communication mode (SCL/SDA for I<sup>2</sup>C, TX/RX for UART).
- 10) Check that the AC coupling capacitors are populated correctly and routing the serial link to the correct connector for Coax or STP mode. For coax boards, capacitors C12 and C13 should be populated. For STP boards, capacitors C3 and C19 should be populated (MAX96717 EV kit boards are shipped with the correct capacitors installed.).
- 11) Check that the microcontroller firmware is active by observing the blinking red Teensy LED at power-up. If the LED is not blinking, refer to the available software documentation to reprogram the microcontroller.
- 12) Check that the PC is detecting the COM port when the micro-USB cable is connected. Use the Windows Device Manager to check COM port status.
- 13) Power-cycle the board and reopen the GUI.
- 14) Try a new or different serializer or deserializer board.



**MAX96717 DPHY EV Kit Package Contents**

ITEM DESCRIPTION	QTY
MAX96717 DPHY EV kit (or a variant)	1
Micro-USB Cable	1
12V DC Wall Supply	1
Coax Cable for Coax EV kits or HMTD cable for HMTD EV kits	1

**Major Component Suppliers**

SUPPLIER	PHONE	WEBSITE
Rosenberger Hochfrequenztechnik GmbH	011-49-86 84-18-0	<a href="http://www.rosenberger.de">www.rosenberger.de</a>
TDK Corp.	547-803-6100	<a href="http://product.tdk.com/info/en/catalog/index.html">product.tdk.com/info/en/catalog/index.html</a>
Diodes Inc.	972-987-3900	<a href="http://www.diodes.com">www.diodes.com</a>
Murata Electronics North America, Inc.	770-436-1300	<a href="http://www.murata-northamerica.com">www.murata-northamerica.com</a>
Coilcraft	847-639-6400	<a href="http://www.coilcraft.com">www.coilcraft.com</a>
Panasonic North America	N/A	<a href="http://na.panasonic.com/us/">na.panasonic.com/us/</a>
ECS, Inc.	913-782-7787	<a href="http://www.ecsxtal.com">www.ecsxtal.com</a>
Vishay	1-402-563-6866	<a href="http://www.vishay.com">www.vishay.com</a>
KYOCERA	N/A	<a href="https://global.kyocera.com/">https://global.kyocera.com/</a>
Sullins Electronics Corp	760-744-0125	<a href="http://www.sullinscorp.com">www.sullinscorp.com</a>

**Ordering Information**

PART	TYPE
MAX96717-AAK-EVK#**	CSI-2 to GMSL2 Serializer DPHY w/COAX
MAX96717-ACK-EVK#**	CSI-2 to GMSL2 Serializer DPHY w/HMTD
MAX96717K-AAK-EVK#**	CSI-2 to GMSL2 Serializer DPHY w/COAX
MAX96717K-ACK-EVK#**	CSI-2 to GMSL2 Serializer DPHY w/HMTD
MAX96717F-AAK-EVK#	CSI-2 to GMSL2 Serializer DPHY w/COAX
MAX96717F-ACK-EVK#*	CSI-2 to GMSL2 Serializer DPHY w/HMTD
MAX96717R-AAK-EVK#**	CSI-2 to GMSL2 Serializer DPHY w/COAX
MAX96717R-ACK-EVK#**	CSI-2 to GMSL2 Serializer DPHY w/HMTD

\*Contact factory.

\*\*Future product – contact factory for availability.

MAX96717 EV Kit Bill of Materials (Coax)

ITEM	QTY	REF DES	VAR STATUS	MAXINV	MFG PART #	MANUFACTURER	VALUE	DESCRIPTION	COMMENTS
1	1	C1	Pref	20-0022P-27J	C1005C0G1H220G050	TDK	22PF	CAPACITOR: SMT (0402); CERAMIC CHIP; 22PF; 50V; TOL=2%; TG=-55 DEGC TO +125 DEGC; TC=C0G	
2	1	C2	Pref	20-0027P-27	C0402C0G500270ANP; GRM1555C1H270JA01	VENKEL LTD.;MURATA	27PF	CAPACITOR: SMT; 0402; CERAMIC; 27pF; 50V; 5%; C0G; -55degC to + 125degC; 0 +30PPM/degC	
3	22	C4, C8, C11, C16, C18, C21-C24, C26-C31, C39, C40, C45, C46, C55, C119, C120	Pref	20-0000U1-DA22	CGA2B1X7R1C104K050BC; GCM155R71C104KA55	TDK;MURATA	0.1UF	CAPACITOR: SMT (0402); CERAMIC CHIP; 0.1UF; 16V; TOL=10%; TG=-55 DEGC TO +125 DEGC; TC=X7R; AUTO; NOTE: PLEASE USE MAXINV 20-000U1-1A	
4	4	C6, C9, C14, C17	Pref	20-000U1-12A	GRM155R71H103JA88	MURATA	0.01UF	CAPACITOR: SMT (0402); CERAMIC CHIP; 0.01UF; 50V; TOL=5%; TG=-55 DEGC TO +125 DEGC; TC=X7R	
5	14	C10, C36-C38, C41-C43, C47-C53	Pref	20-0010U-BA92	GRT188R61C106KE13	MURATA	10UF	CAPACITOR: SMT (0603); CERAMIC CHIP; 10UF; 16V; TOL=10%; TG=-55 DEGC TO +85 DEGC; TC=X5R; AUTO	
6	2	C12, C13	Pref	20-0000U1-04A	CGA2B3X7R1H104K050BB; C1005X7R1H104K050BB; GRM155R71H104KE14; GCM155R71H104KE02; C1005X7R1H104K050BE; UMK105B7104KV-FR; CGA2B3X7R1H104K050BE	TDK;TDK;MURATA;MURATA; TDK;TAIYO YUDEN;TDK	0.1UF	CAPACITOR: SMT (0402); CERAMIC CHIP; 0.1UF; 50V; TOL=10%; TG=-55 DEGC TO +125 DEGC; TC=X7R	
7	1	C15	Pref	20-0000U-Ca22	CGA3E1X7R1V105K	TDK	1UF	CAPACITOR: SMT (0603); CERAMIC CHIP; 1UF; 35V; TOL=10%; TG=-55 DEGC TO +125 DEGC; TC=X7R; AUTO; NOTE: SET TO OBSOLETE USE MAXINV NO 20-0000U-Ba46	
8	3	C20, C25, C44	Pref	20-002U2-11D	GRM188Z71C225KE43	MURATA	2.2UF	CAPACITOR: SMT (0603); CERAMIC CHIP; 2.2UF; 16V; TOL=10%; TG=-55 DEGC TO +125 DEGC; TC=X7R	
9	2	C34, C35	Pref	20-0047U-A42	C3216X5R1E47M160AC	TDK	47UF	CAPACITOR: SMT (1206); CERAMIC CHIP; 47UF; 25V; TOL=20%; MODEL=C SERIES; TG=-55 DEGC TO +85 DEGC; TC=X5R; NOTE: THESE PARTS HAVE 28 WEEKS LEAD TIME; MANUFACTURING DELAYS HAVE BEEN REPORTED ON THIS PRODUCT	
10	2	C54, C56	Pref	20-004U7-X3	C1608X5R0J475M080AB; GRM188R60J475ME19; JMK107B475MA	TDK;MURATA;TAIYO YUDEN	4.7UF	CAPACITOR: SMT (0603); CERAMIC; 4.7UF; 6.3V; TOL=20%; MODEL=C SERIES; TG=-55 DEGC TO +85 DEGC; TC=X5R	
11	1	C57	Pref	20-0100U-CA04	T491X107K025A	KEMET	100UF	CAPACITOR: SMT (7343-43); TANTALUM CHIP; 100UF; 25V; TOL=10%	
12	2	CFG0, CFG1	Pref	02-TPMINI5000-00		5000 KEYSTONE	N/A	TEST POINT; PIN DIA=0.1N; TOTAL LENGTH=0.3IN; BOARD HOLE=0.04IN; RED; PHOSPHOR BRONZE WIRE SILVER PLATE FINISH; RECOMMENDED FOR BOARD THICKNESS=0.082IN; NOT FOR COLD TEST; NOTE: SET TO OBSOLETE DUE TO CORRECTION IN STEP MODEL COLOR	
13	2	D1, D2	Pref	30-ES1D-00	ES1D	FAIRCHILD SEMICONDUCTOR	ES1D	DIODE; RECT; SMA (DO-214AC); PIV=200V; IF=1A	
14	1	D3	Pref	30-DFLS140L-00	DFLS140L	DIODES INCORPORATED	DFLS140L	DIODE; SCH; SMT (POWERD-123); PIV=40V; IF=1A	
15	1	D4	Pref	30-B360B13F-00	B360B-13-F	DIODES INCORPORATED	B360B-13-F	DIODE; SCH; SCHOTTKY BARRIER DIODE; SMB; PIV=60V; IFS=3A; -55 DEGC TO +125 DEGC	
16	2	DS1, DS3	Pref	30-SMLP11UTT86-00	SML-P11UTT86	ROHM	SML-P11UTT86	DIODE; LED; SMT; PIV=1.8V; IF=0.02A	
17	1	DS2	Pref	30-SMLP11MTT86-00	SML-P11MTT86	ROHM	SML-P11MTT86	DIODE; LED; SMT; PIV=5V; IF=0.02A	
18	1	DS4	Pref	30-SMLE13BC8T-00	SMLE13BC8T	ROHM SEMICONDUCTOR	SMLE13BC8T	DIODE; LED; SML-E1 SERIES; BLUE; SMT (0603); VF=2.9V; F=0.005A	
19	1	EV_KIT_BOX1	Pref	00-SAMPLE-01	SRLZR_COAX_HSD_HMTD_BOX	MAXIM	SRLZR_COAX_HSD_HMTD_BOX	EV KIT PACKAGING SET FOR SERIALIZER COAX OR HSD OR_HMTD BOX; LARGE BROWN 15 1/8 inch X 8 3/4 inch X 3 inch	
20	3	EXP_J10, VDD_REF	Pref	01-PBC02SAAN2P-21	PBC02SAAN	SULLINS ELECTRONICS CORP.	PBC02SAAN	CONNECTOR; MALE; THROUGH HOLE; BREAKAWAY; STRAIGHT; 2PINS	
21	2	EXT_GND	Pref	01-9020BUSS20AWG-00	9020 BUSS	WEICO WIRE	MAXIMPAD	EVK KIT PARTS; MAXIM PAD; WIRE; NATURAL; SOLID; WEICO WIRE; SOFT DRAWN BUS TYPE-S; 20AWG	
22	1	EXT_UC	Pref	01-PBC04SAAN4P-21	PBC04SAAN	SULLINS ELECTRONICS CORP.	PBC04SAAN	CONNECTOR; MALE; THROUGH HOLE; BREAKAWAY; STRAIGHT; 4PINS; -65 DEGC TO +125 DEGC	
23	1	J1	Pref	01-PBC12SAAN12P-21	PBC12SAAN	SULLINS ELECTRONICS CORP.	PBC12SAAN	CONNECTOR; MALE; THROUGH HOLE; BREAKAWAY; STRAIGHT; 12PINS; -65 DEGC TO +125 DEGC	
24	1	J3	Pref	01-198156815P-26	1981568-1	TE CONNECTIVITY	1981568-1	CONNECTOR; FEMALE; SMT; MICRO USB STANDARD TYPE B ASSY; RIGHT ANGLE; 5PINS	
25	1	J4	Pref	01-QTH03001LDA-17	QTH-030-01-L-D-A	SAMTEC	QTH-030-01-L-D-A	CONNECTOR; FEMALE; SMT; HIGH SPEED GROUND PLANE HEADER; STRAIGHT THROUGH; 60PINS	
26	1	J5	Pref	01-PJ002AH3P-27	PJ-002AH	CUI INC.	PJ-002AH	CONNECTOR; MALE; THROUGH HOLE; DC POWER JACK; RIGHT ANGLE; 3PINS	
27	1	J6	Pref	01-3935700022P-25		393570002 MOLEX	393570002	CONNECTOR; FEMALE; THROUGH HOLE; 0.3MM PITCH BEAU EUROSTYLE FIXED MOUNT PCB TERMINAL BLOCK; RIGHT ANGLE; 2PINS	
28	4	J7, TNZ_SCLR/X, TNZ_SDA/TX, VDDIO	Pref	01-PBC03SABN3P-21	PBC03SABN	SULLINS	PBC03SABN	CONNECTOR; MALE; THROUGH HOLE; BREAKAWAY; STRAIGHT; 3PINS	
29	1	JAP	Pref	01-59S2AQ40MT5Z15P-01	59S2AQ-40MT5-Z_1	ROSENBERGER	59S2AQ-40MT5-Z_1	CONNECTOR; MALE; THROUGH HOLE; FAKRA-HF RIGHT ANGLE PLUG PCB WITH HOUSING; RIGHT ANGLE; 5PINS	
30	1	L1	Pref	EL111000001783	MSS6132T-223ML	COILCRAFT	22UH	INDUCTOR; SMT; SHIELDED; 22UH; 20%; 1.9A	
31	2	L2, L4	Pref	EL111000001781	PFL1609-471ME	COILCRAFT	0.47UH	INDUCTOR; SMT; SHIELDED; 0.47UH; 20%; 1.3A	
32	2	L3, L15	Pref	50-002U2-0MW	TFM201610ALMA2R2MTAA	TDK	2.2UH	INDUCTOR; SMT (2016); THIN FILM; 2.2UH; TOL=+/-20%; 2.1A	
33	2	L5, L14	Pref	50-004U7-0FE	DFE252012P-4R7M=P2	MURATA	4.7UH	INDUCTOR; SMT (2520); FERRITE CORE; 4.7UH; TOL=+/-20%; 1.7A	
34	5	L8, L9, L11, L13, L17	Pref	51-00600-0AU	BLM18KG601SM1	MURATA	600	INDUCTOR; SMT (0603); FERRITE-BEAD; 600; TOL=+/-25%; 1.3A	
35	1	L12	Pref	50-RFCMF1220100M3-00	RFCMF1220100M3	WALSIN TECHNOLOGY CORPORATION	RFCMF1220100M3	INDUCTOR; SMT; CERAMIC CHIP; CHOKE; 0.3A	
36	1	L16	Pref	50-00120-SM3A	BLM18SG121TN1	MURATA	120	INDUCTOR; SMT (0603); FERRITE-BEAD; 120; TOL=+/-25%; 3A	
37	1	L18	Pref	00-SAMPLE-02	1210POC-682MR	COILCRAFT	6.8UH	EVKIT PART - INDUCTOR; SMT; FERRITE; CHOKE; TOL=+/-20%; 1A	
38	1	POWER	Pref	01-PEC04SAAN4P-21	PEC04SAAN	SULLINS ELECTRONICS CORP.	PEC04SAAN	CONNECTOR; MALE; THROUGH HOLE; BREAKAWAY; STRAIGHT; 4PINS	
39	11	R2, R3, R29, R40-R42, R44, R45, R60, R62, R65	Pref	80-0010K-Q6	ERJ-2GEJ103	PANASONIC	10K	RESISTOR; 0402; 10K OHM; 5%; 200PPM; 0.10W; THICK FILM	
40	2	R4, R5	Pref	80-0020K-Q6	ERJ-2GEJ203	PANASONIC	20K	RESISTOR; 0402; 20K OHM; 5%; 200PPM; 0.10W; THICK FILM	
41	19	R6, R7, R9-R11, R13, R14, R28, R30-R32, R43, R61, R63, R64, R67, R68, R150, R151	Pref	80-0000R-26A	ERJ-2GEOR00	PANASONIC	0	RESISTOR; 0402; 0 OHM; 0%; JUMPER; 0.10W; THICK FILM	

MAX96717 EV Kit Bill of Materials (Coax) (continued)

ITEM	QTY	REF DES	VAR STATUS	MAXINV	MFG PART #	MANUFACTURER	VALUE	DESCRIPTION	COMMENTS
42	1	R12	Pref	80-0200R-23	CRCW0402200RFK	VISHAY DALE	200	RESISTOR; 0402; 200 OHM; 1%; 100PPM; 0.063W; THICK FILM	
43	8	R15, R16, R21, R23, R121, R128-R130	Pref	80-04K98-18	ERJ-2RKF4991	PANASONIC	4.99K	RESISTOR; 0402; 4.99K OHM; 1%; 100PPM; 0.10W; THICK FILM	
44	1	R18	Pref	80-049R9-24	CRCW060349R9FK	VISHAY DALE	49.9	RESISTOR; 0603; 49.9 OHM; 1%; 100PPM; 0.10W; THICK FILM	
45	2	R19, R79	Pref	80-0200K-BA14	3214W-1-204	BOURNS	200K	RESISTOR; SMT-J LEAD; 3214 SERIES; 200K OHM; 10%; 100PPM; 0.25W	
46	2	R24, R25	Pref	80-005K1-24	ERJ-3EKF5101	PANASONIC	5.1K	RESISTOR; 0603; 5.1K OHM; 1%; 100PPM; 0.10W; THICK FILM	
47	1	R26	Pref	80-0402R-24	CRCW0603402RFK	VISHAY DALE	402	RESISTOR; 0603; 402 OHM; 1%; 100PPM; 0.10W; THICK FILM	
48	1	R27	Pref	80-024K9-23	CRCW040224K9FKEDHP	VISHAY DALE	24.9K	RESISTOR; 0402; 24.9K OHM; 1%; 100PPM; 0.125W; THICK FILM. NOTE SET TO OBSOLETE: CHANGE POWER RATING-USE MAXINV ER11100002796	
49	3	R33, R34, R39	Pref	80-0001K-18	ERJ-2RKF1001	PANASONIC	1K	RESISTOR; 0402; 1K OHM; 1%; 100PPM; 0.10W; THICK FILM	
50	2	R35, R36	Pref	80-0033R-23	CRCW040233R0FK	VISHAY DALE	33	RESISTOR; 0402; 33 OHM; 1%; 100PPM; 0.0625W; THICK FILM	
51	1	R37	Pref	80-0470R-AA23	ERJ-2RKF4700	PANASONIC	470	RESISTOR; 0402; 470 OHM; 1%; 100PPM; 0.1W; THICK FILM	
52	5	R71, R73-R76	Pref	80-0000R-27	CRCW06030000ZS; MCR03EZP-0000; ERJ-3GEY0R00	VISHAY DALE;ROHM; PANASONIC	0	RESISTOR; 0603; 0 OHM; 0%; JUMPER; 0.10W; THICK FILM	
53	1	SW1	Pref	11-1101M2S3AQE2-00	1101-M2-S3-A-Q-E-2	C&K COMPONENTS	1101-M2-S3-A-Q-E-2	SWITCH; SPDT; THROUGH HOLE; RIGHT ANGLE; 120V; 6A; 1000 SERIES; RCOIL=0.1 OHM; RINSULATION=100G OHM	
54	2	SW3, SW4	Pref	11-KMR421GLFS-00	KMR421G LFS	C&K COMPONENTS	KMR421G LFS	SWITCH; SPST; SMT; STRAIGHT; 32V; 0.05A; MICROMINIATURE SMT TOP ACTUATED; RCOIL=0.1 OHM OHM; RINSULATION=1G OHM OHM	
55	1	U1	Pref	00-SAMPLE-03	MAX96717GTJVY+	MAXIM	MAX96717GTJVY+	EVKIT PART - IC; SRLZR; CSI-2 TO GMSL3 SERIALIZER; TQFN32-EP; PACKAGE CODE: T3255+8; PACKAGE OUTLINE: 21-0140; PACKAGE LAND PATTERN: 90-0013	
56	2	U2, U3	Pref	10-74LVC1G86GV-U	74LVC1G86GV	NXP	74LVC1G86GV	IC; XOR; 2-INPUT EXCLUSIVE-OR GATE; SOT753	
57	2	U4, U5	Pref	10-MAX5419PETA-T	MAX5419PETA+	MAXIM	MAX5419PETA+	IC; DPOT; 200K OHM; 256-TAP NONVOLATILE I2C-INTERFACE DIGITAL POTENTIOMETER; TQFN8-EP;NOTE: SET TO OBSOLETE TO USE MAXIM 90-SPECS FOOTPRINT	
58	1	U6	Pref	10-MK20DX256VLH7-C	MK20DX256VLH7	FREESCALE	MK20DX256VLH7	IC; UCON; KINETIS K2X MCU FAMILY; LQFP64	
59	1	U7	Pref	10-MKL02Z32VFG4-G	MKL02Z32VFG4	FREESCALE	MKL02Z32VFG4	IC; UCON; KINETIS KL02 32 KB FLASH; 48 MHZ CORTEX-M0+ BASED MICROCONTROLLER; QFN16-EP	
60	2	U8, U9	Pref	10-MAX3373EEKA-K	MAX3373EEKA+	MAXIM	MAX3373EEKA+	IC; TRANS; +/-15KV ESD-PROTECTED; 16MPBS; DUAL LOW-VOLTAGE LEVEL TRANSLATOR; SOT23-8;NOTE: SET TO OBSOLETE TO USE MAXIM 90-SPECS FOOTPRINT	
61	1	U10	Pref	10-MAX16922ATPHV-T	MAX16922ATPHV+	MAXIM	MAX16922ATPHV+	IC; CONV; 2.2MHZ; DUAL; STEP-DOWN DC-DC CONVERTER; DUAL LDOS AND RESET; TQFN20-EP;NOTE: SET TO OBSOLETE TO USE MAXIM 90-SPECS FOOTPRINT	
62	1	U11	Pref	00-SAMPLE-04	MAX20019ATBIV+	MAXIM	MAX20019ATBIV+	EVKIT PART-IC; VCON; 3.2MHZ; 500MILLIAMPERE DUAL STEP-DOWN CONVERTER FOR AUTOMOTIVE CAMERA; PACKAGE OUTLINE: 21-100125; LAND PATTERN DRAWING NO.: 90-100079; PACKAGE CODE: T1032+2C; TDFN10-EP;NOTE: SET TO OBSOLETE TO USE MAXIM 90-SPECS FOOTPRINT	
63	1	Y1	Pref	60-0025M-0CB	ECS-250-18-33Q-DS	ECS INC	25MHZ	CRYSTAL; SMT 3.2X2.5; 18PF; 25MHZ; +/-30PPM; +/-100PPM	
64	1	Y2	Pref	60-0016M-0CN	CX2016DB16000DOPSWC1	KYOCERA	16MHZ	CRYSTAL; SMT 2MMX1.6MM; 8PF; 16MHZ; +/-50PPM; +/-200PPM	
65	1	PCB	-	EPCB96717CSIDPHY	MAX96717CSIDPHY	MAXIM	PCB	PCB;MAX96717CSIDPHY	
TOTAL	172								

PURCHASE (DNP)									
ITEM	QTY	REF DES	VAR STATUS	MAXINV	MFG PART #	MANUFACTURER	VALUE	DESCRIPTION	COMMENTS
1	2	C3, C19	DNP	20-000U1-04A	CGA2B3X7R1H104K050BB; C1005X7R1H104K050BB; GRM155R71H104KE14; GCM155R71H104KE02; C1005X7R1H104K050BE; UMK105B7104KV-FR; CGA2B3X7R1H104K050BE	TDK;TDK;MURATA;MURATA; TDK;TAYO YUDEN;TDK	0.1UF	CAPACITOR; SMT (0402); CERAMIC CHIP; 0.1UF; 50V; TOL=10%; TG=-55 DEGC TO +125 DEGC; TC=X7R	
2	1	J2	DNP	N/A	E6S201-40MT5-Z	ROSENBERGER	E6S201-40MT5-Z	EVKIT PART - CONNECTOR; MALE; THROUGH HOLE; PLUG PCB; RIGHT ANGLE; 2PINS; NOTE: PRELIMINARY DATASHEET	
3	10	R1, R8, R20, R22, R3	DNP	80-0000R-26A	ERJ-2GE0R00	PANASONIC	0	RESISTOR; 0402; 0 OHM; 0%; JUMPER; 0.10W; THICK FILM	
4	1	R17	DNP	80-049K9-24	CRCW060349K9FK; ERJ-3EKF4992	VISHAY DALE;PANASONIC	49.9K	RESISTOR; 0603; 49.9K OHM; 1%; 100PPM; 0.10W; THICK FILM	
5	1	R77	DNP	80-0000R-27	CRCW06030000ZS; MCR03EZP-0000; ERJ-3GEY0R00	VISHAY DALE;ROHM; PANASONIC	0	RESISTOR; 0603; 0 OHM; 0%; JUMPER; 0.10W; THICK FILM	
TOTAL	15								

not assembled on PCB and will be shipped with PCB									
ITEM	QTY	REF DES	VAR STATUS	MAXINV	MFG PART #	MANUFACTURER	VALUE	DESCRIPTION	COMMENTS
1	1	PACKOUT_BOX	Pref	88-00713-LRG	88-00713-LRG	N/A	N/A	BOX+LARGE BROWN 15 1/8" X 8 3/4 X 3"	
2	1	PACKOUT_BOX	Pref	87-02163-000	87-02163-000	N/A	N/A	ESD BAG+-BAG; STATIC SHIELD ZIP 8"X10"; W/ ESD LOGO	
3	1	PACKOUT_BOX	Pref	85-MAXKIT-PNK	85-MAXKIT-PNK	N/A	N/A	PNK FOAM;FOAM;ANTI-STATIC PE 12inX12inX5MM - PACKOUT	
4	1	PACKOUT_BOX	Pref	EVINSERT	EVINSERT	N/A	N/A	WEB INSTRUCTIONS FOR MAXIM DATA SHEET	
5	1	PACKOUT_BOX	Pref	85-84003-006	85-84003-006	N/A	N/A	LABEL(EV KIT BOX) - PACKOUT	
6	1	PACKOUT_BOX	Pref	EH111000002613	AK67421-0.5	ASSMANN	N/A	CONNECTOR; USB CABLE; MALE-MALE; USB_2.0; 5PINS-4PINS; 500MM	
7	1	PACKOUT_BOX	Pref	EH111000001907	WSU120-2000	TRIAD MAGNETICS	N/A	ACCESSORY; WALL ADAPTER; VI-(90-264VAC); VO-(12VDC); 6FT	
TOTAL	7								





MAX96717 EV Kit Schematic (continued)

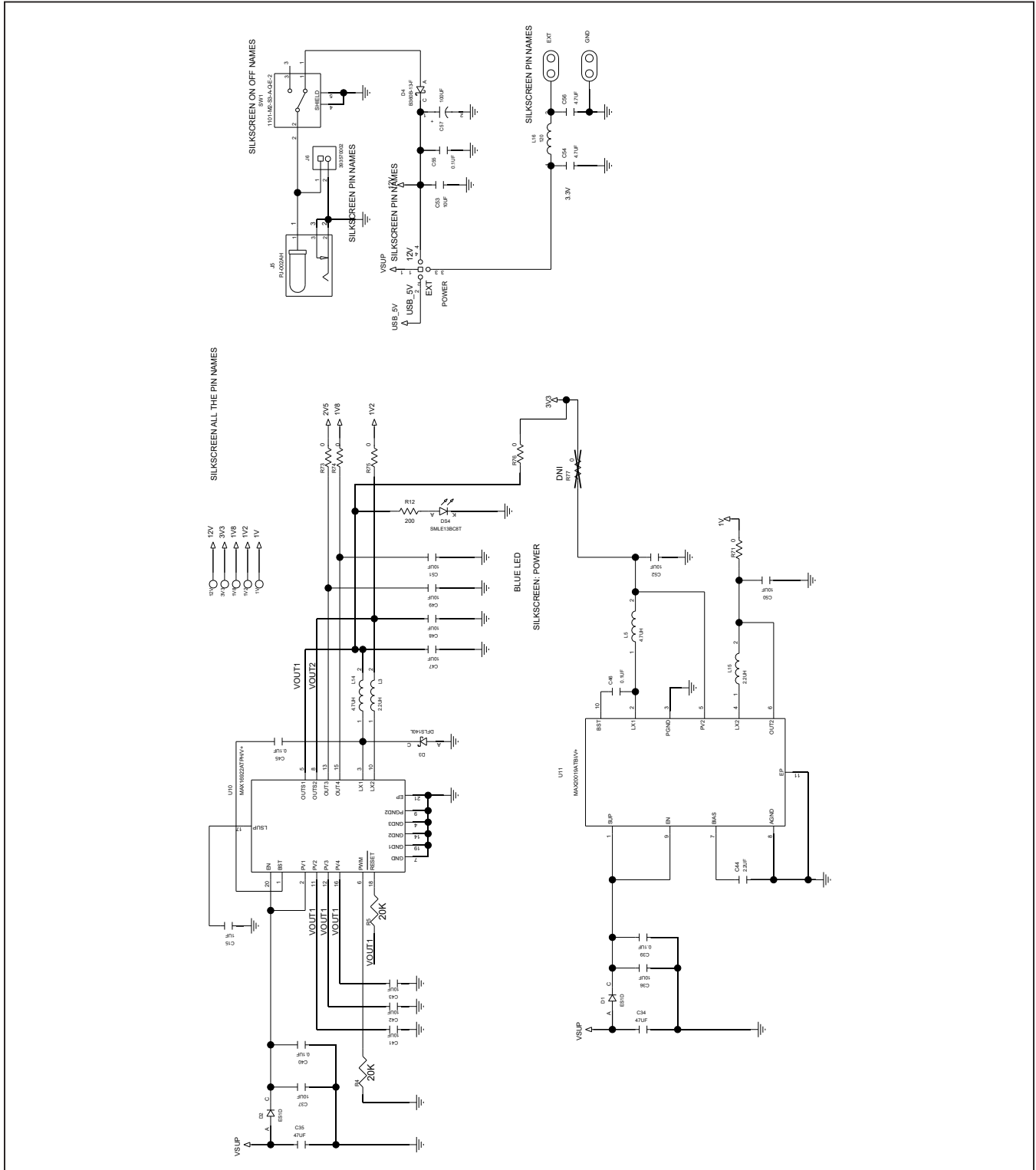

MAX96717 EV Kit Schematic (continued)

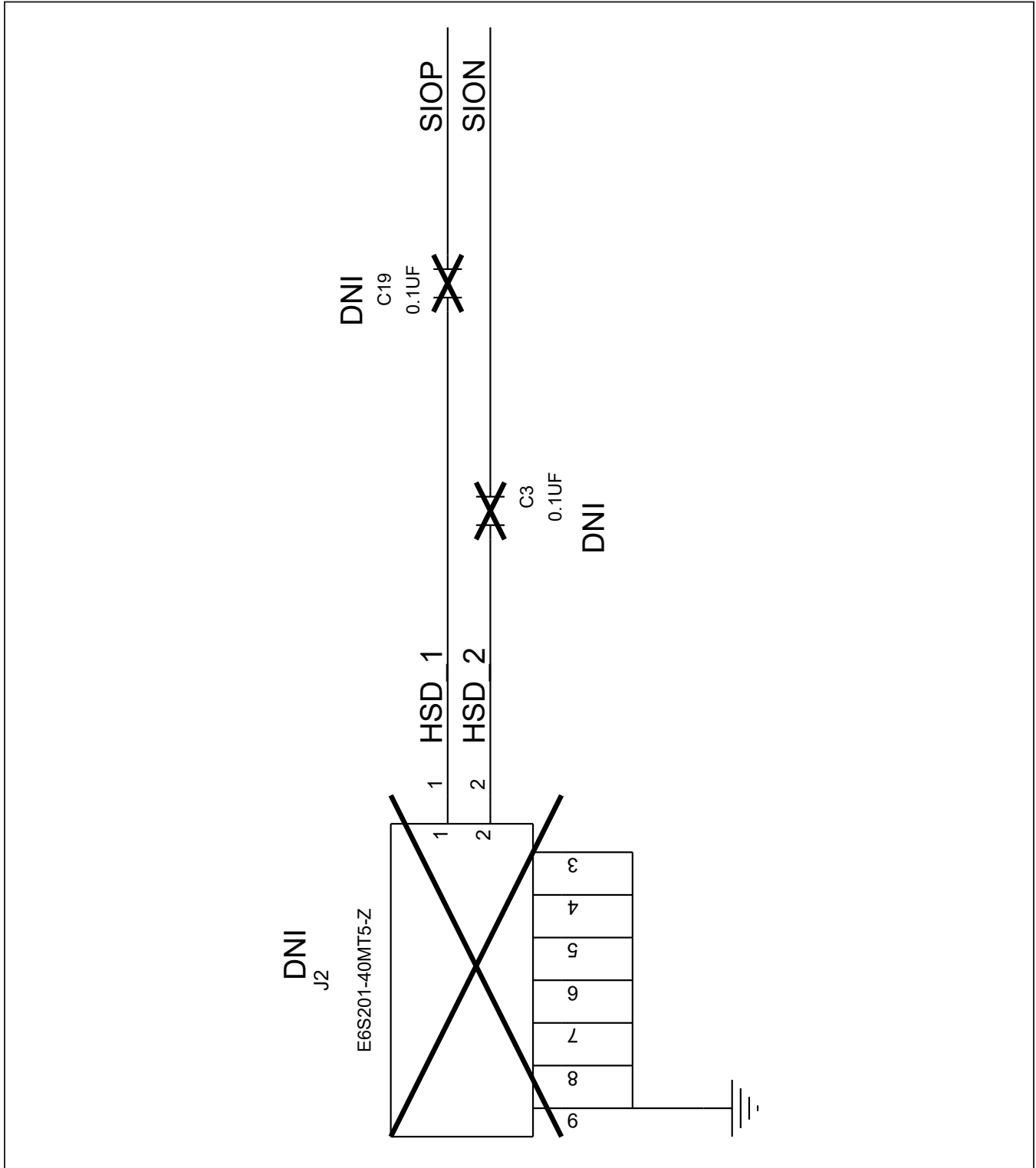



MAX96717 EV Kit Schematic (continued)

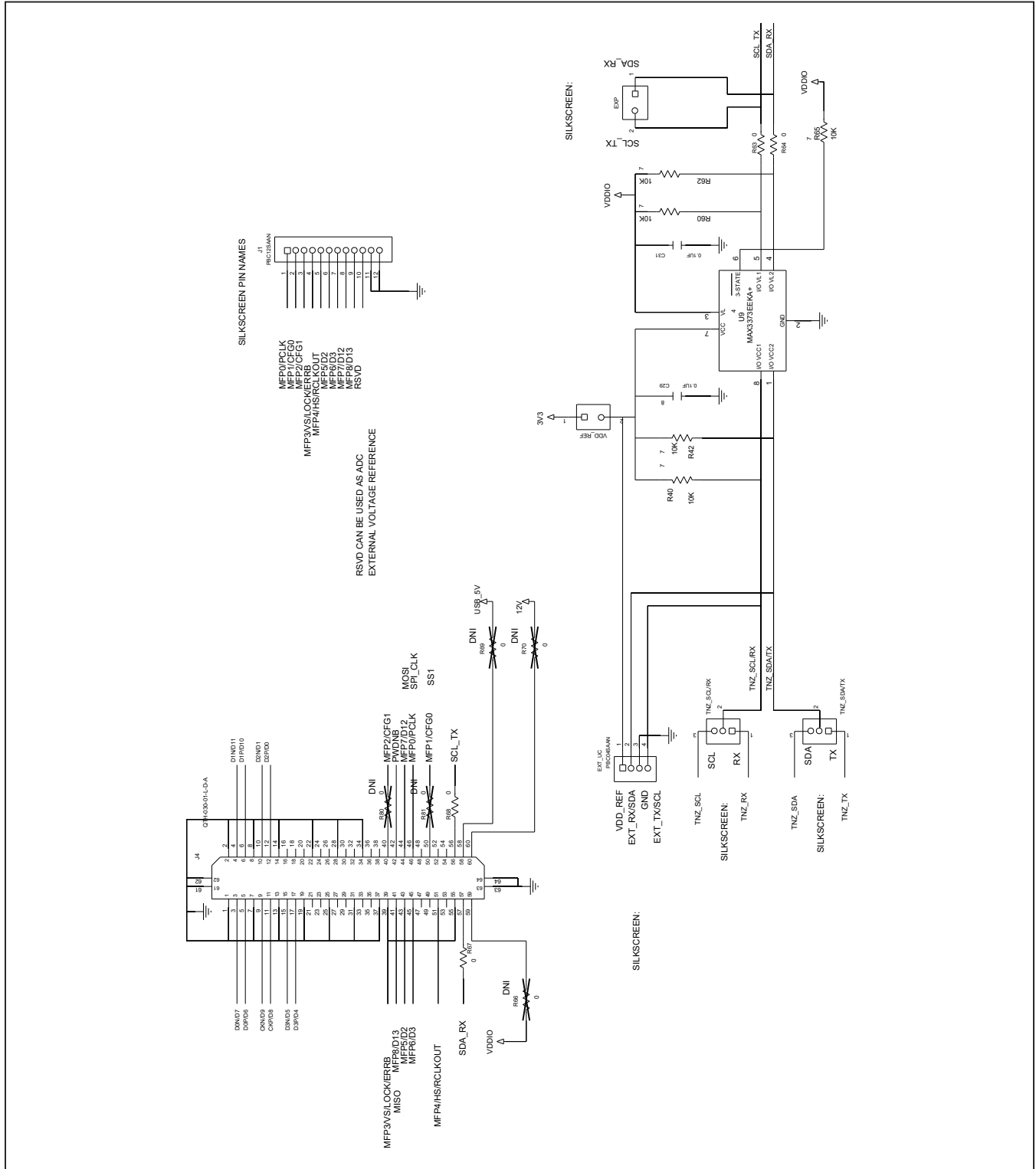

MAX96717 EV Kit Layout

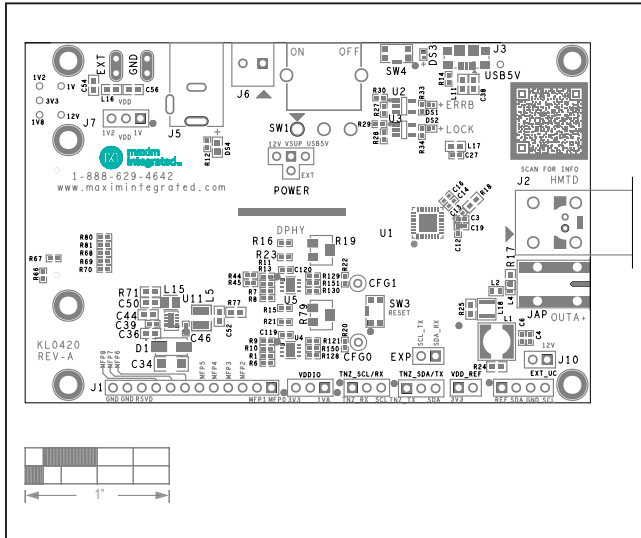

MAX96717 EV Kit—Silk Top

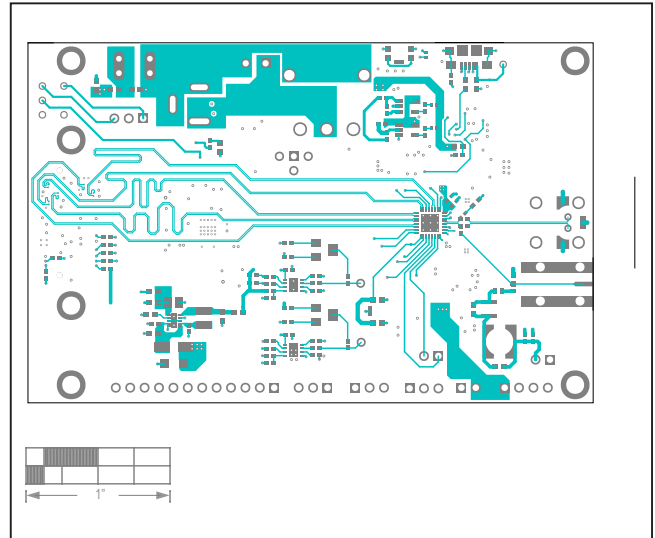

MAX96717 EV Kit—Top

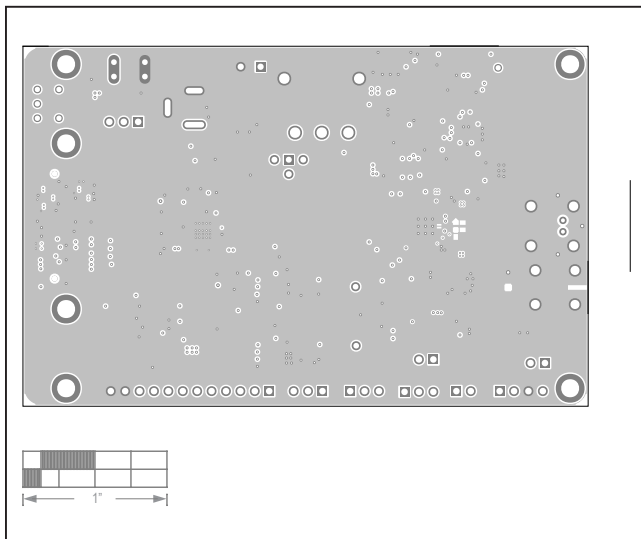

MAX96717 EV Kit—Layer2

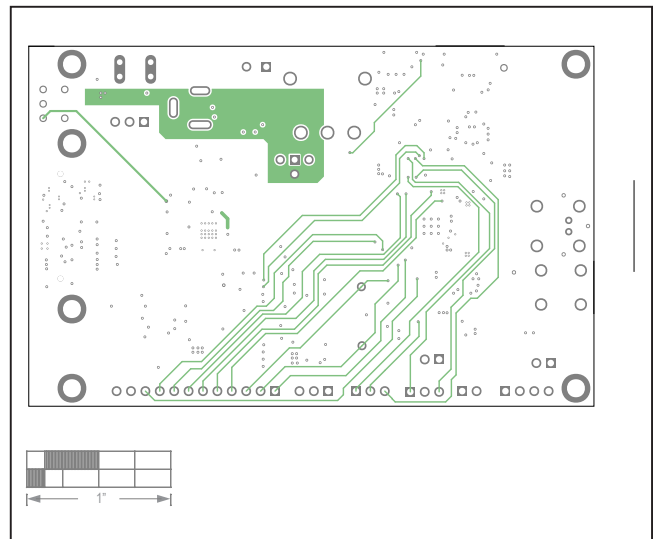

MAX96717 EV Kit—Layer3

MAX96717 EV Kit Layout (continued)

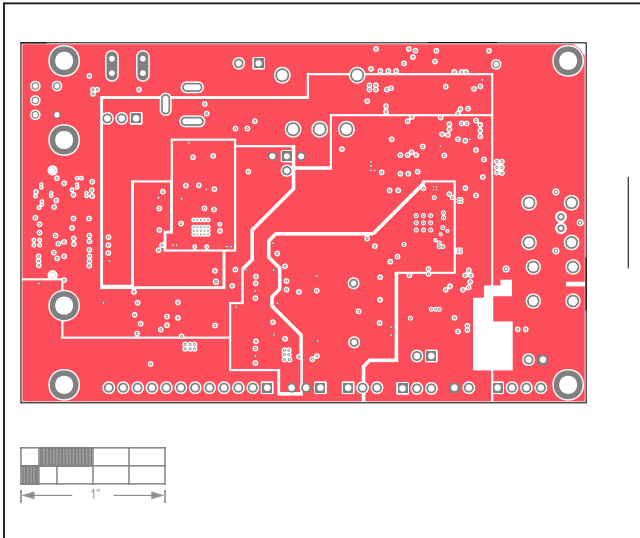

MAX96717 EV Kit—Layer4

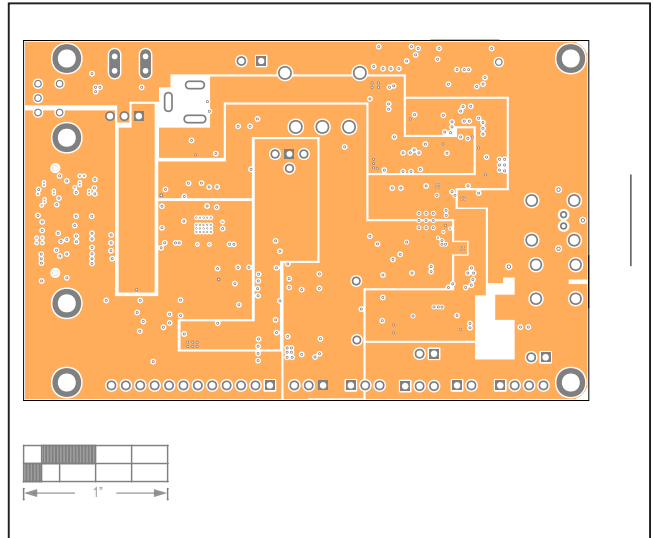

MAX96717 EV Kit—Layer5

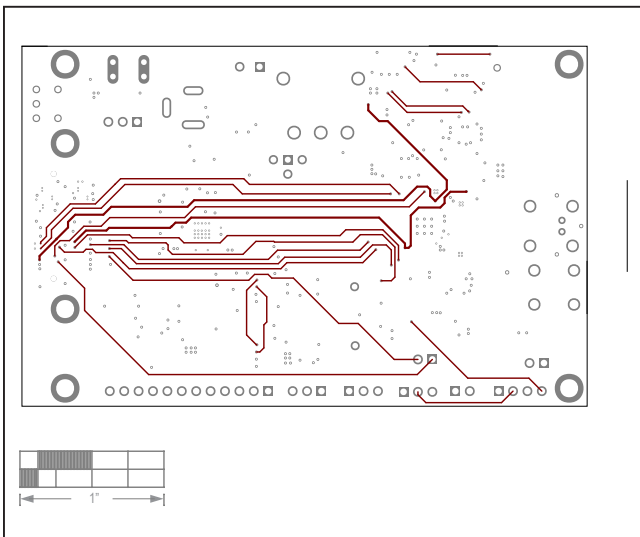

MAX96717 EV Kit—Layer6

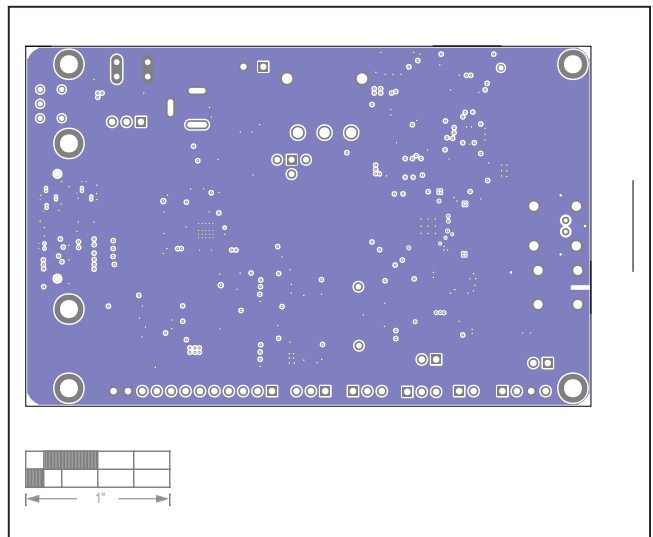

MAX96717 EV Kit—Layer7

MAX96717 EV Kit Layout (continued)

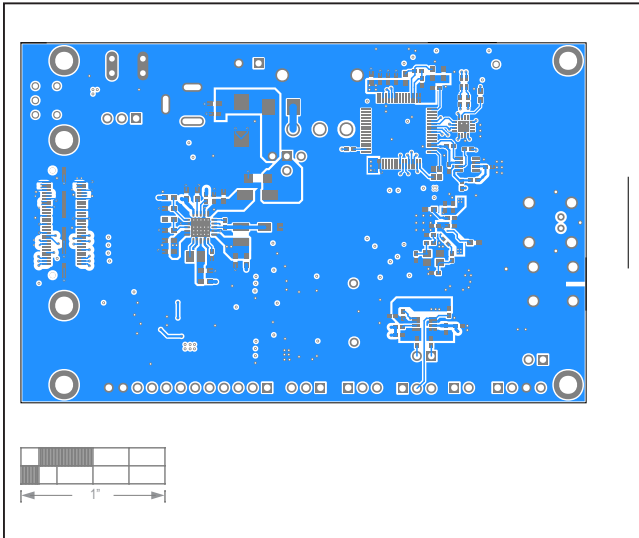

MAX96717 EV Kit—Bottom

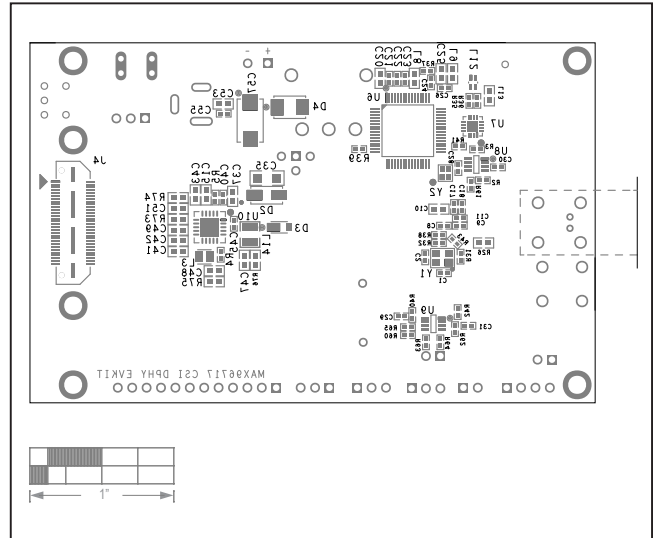

MAX96717 EV Kit—Silk Bottom

Revision History

REVISION NUMBER	REVISION DATE	DESCRIPTION	PAGES CHANGED
0	9/22	Initial release	—
1	9/22	Indicating future product use in the Ordering Information table for MAX96717/K/R.	7
2	9/22	Updated part numbers in header	All



Information furnished by Analog Devices is believed to be accurate and reliable. However, no responsibility is assumed by Analog Devices for its use, nor for any infringements of patents or other rights of third parties that may result from its use. Specifications subject to change without notice. No license is granted by implication or otherwise under any patent or patent rights of Analog Devices. Trademarks and registered trademarks are the property of their respective owners.