

PWM and Tach Output Brushless DC Fan

06025SA-12S-AU-D6

NMB

General Specifications

Motor Type:

DC Brushless Single Phase Motor

Motor Protection:

Auto Restart / Polarity Protection (Motor withstands reverse connection for positive and negative leads.)

Insulation Resistance:

10MΩ or over with a DC 500V Megger

Dielectric Withstand Voltage:

AC 700V 1sec or 500V 1min

Allowable Ambient Temperature Range:

-10°C ~ + 70°C (Operating)

-40°C ~ + 70°C (Storage)

(non-condensing environment)



*For reference only. Please refer to fan outline for details

Characteristic Curves

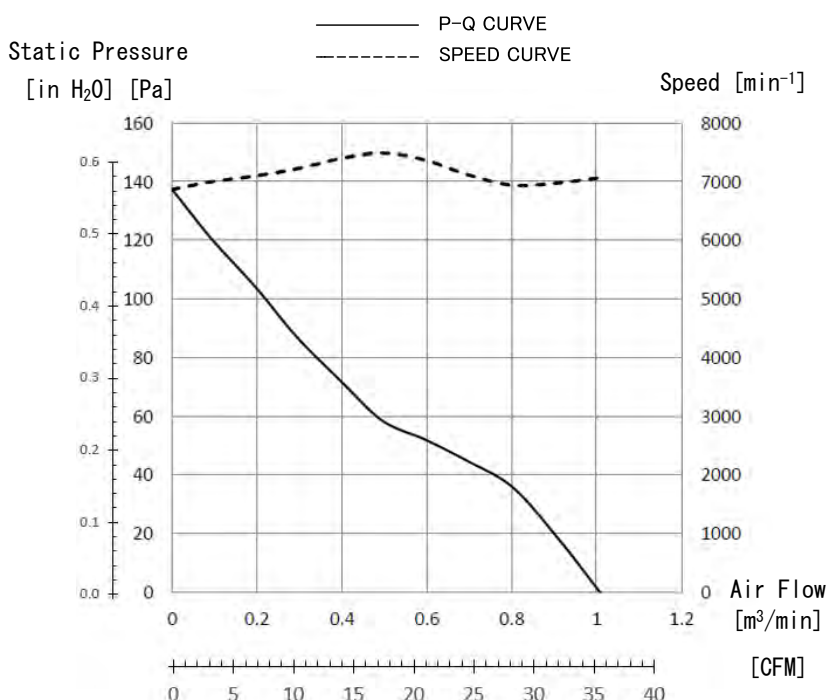

Features

- High Performance, four wire, PWM fan with tach signal
- Efficient motor technology, high torque, and aerodynamic impeller design
- Energy saving, low vibration, and increased life expectancy
- Available in 12 volts with tach output and PWM speed control
- Outfitted with NMB precision machined ball bearings for long life
- Single phase motor design for high speed and efficient cooling

Life Expectancy L10

40,000 Hours at 60°C

*Fan life expectation is based on free air operation at 60°C, rated voltage, and indoor benign lab environment

*1: Values in Free Air

Specifications

MODEL	Rating Voltage	Operating Voltage	Current		Input Power		Speed (min ⁻¹)*1	Max. Air Flow		Max. Static Pressure		Noise (dB)*1	Mass (g)
	(V)	(V)	Avg (A)*1	Max (A)*1	Avg (W)*1	Max (W)*1		(CFM)	(m ³ /min)	(in H ₂ O)	(Pa)		
	(V)	(V)	(A)*1	(A)*1	(W)*1	(W)*1		(min ⁻¹)*1	(m ³ /min)	(in H ₂ O)	(Pa)		
06025SA-12S-AU-D6	12	7.0 to 13.2	0.34	0.60	4.08	7.20	7000	35.7	1.01	0.55	138	42.5	65.0

PWM Specifications

Connection

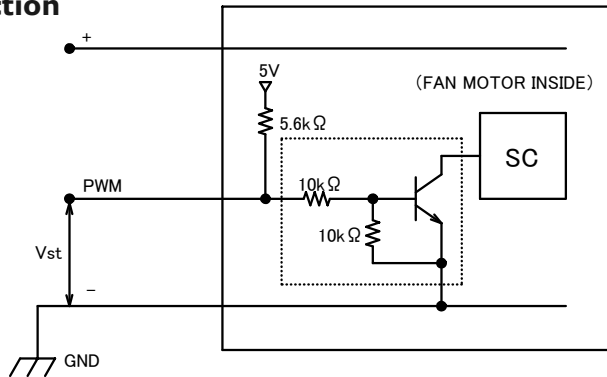

1. PWM Control

- Vst = Low Level (0V~0.4V) → Stop (On Duty 0%)
- Vst = High Level (4.0V~5.0V) → Full Speed (On Duty 100%)
- Vst = Open → Full Speed

2. PWM Duty & PWM Input Pulse

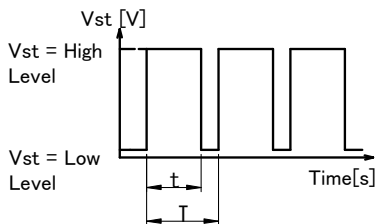

PWM Duty means that a ratio of high level time (t)/PWM Input Pulse(T).

$$(t/T) \times 100 : \text{On Duty } 0\% \sim 100\%$$

$$\text{PWM Frequency } f = 25[\text{kHz}]$$

3. The condition for PWM control are as follows

- When you use this under PWM control, always be sure the motor's operation under practical mounting state. Fan motor may not start up caused by PWM control at very low speed condition.)
- To run at Rating Voltage
- Please use the start with Duty 20% or more at 25kHz.[At rated voltage input, Ambient temperature 25°C]

PWM Characteristic Curve

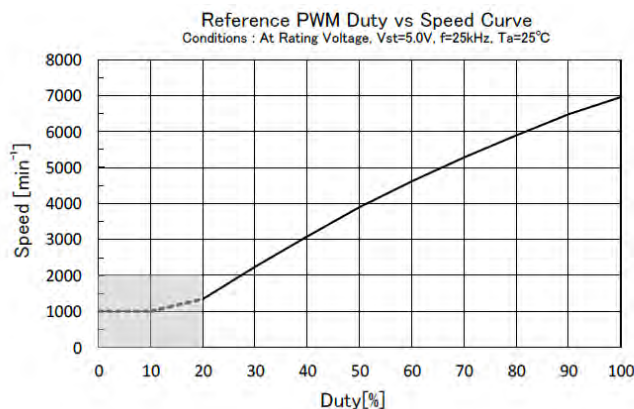

TACHO Specifications

Tachometer Signal

1. Output Circuit: Open Drain
2. Specification
Absolute Maximum Ratings at Ta=25°C
V_{DSmax}: +15V
I_{Dmax}: 5mA[V_{CE(sat)}max=1.5V]

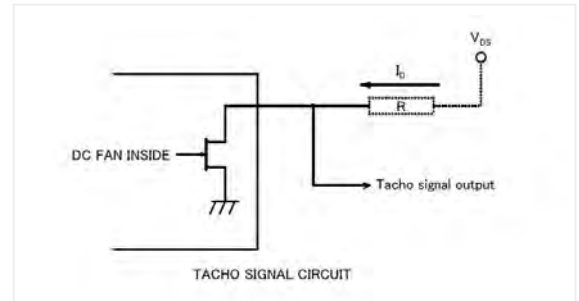

3. Output Waveform: At Rated Voltage Output Signal Voltage

Case-1

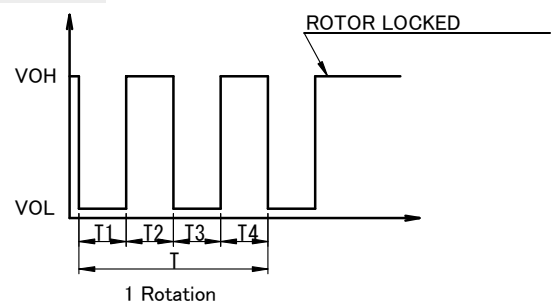

Case-2

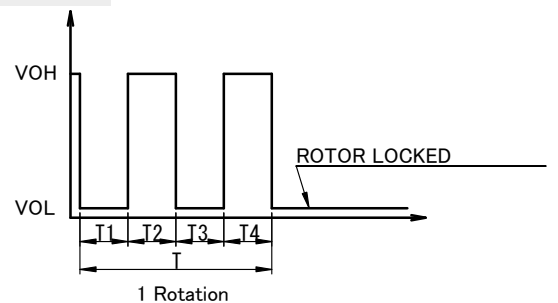

- 1) When the rotor is locked at VOH position of signal, signal keeps VOH position.
- 2) When the rotor is locked at VOL position of signal, signal keeps VOL position.
- 3) T=T1+T2+T3+T4=60/m=1 rotation

$$m: \text{Fan Speed (min}^{-1}\text{)}$$

$$\text{Tacho Duty Cycle} = 50\% \pm 10\%$$

PWM and Tach Output Brushless DC Fan

06025SA-12S-AU-D6

NMB

Outlines

(Name Plate)

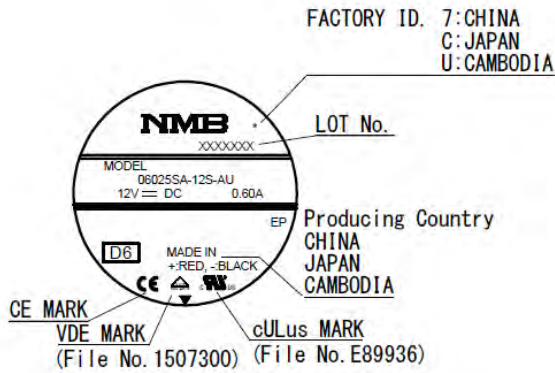

Materials

- Casing:** Plastic (Black UL94V-0)
- Impeller:** Plastic (Black UL94V-0)
- Bearing:** Ball Bearing
- Lead Wire:** UL3385 AWG26
 - (+): Red
 - (-): Black
- Tacho:** White
- PWM:** Brown

(Outline)

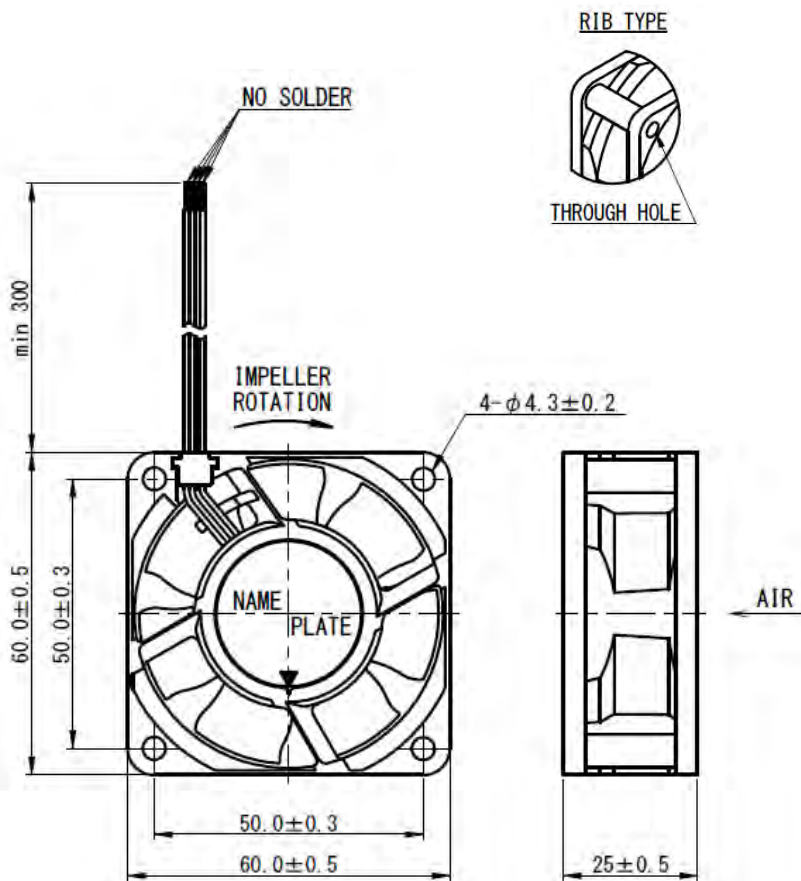

(Panel Out-line)

