

Power Management Switch IC Series for PCs and Digital Consumer Product

Power Switch ICs ExpressCard™



BD4153FV, BD4153EFV, BD4154FV, BD4155FV, BD4156MUV

●Description

BD4153FV, BD4153EFV, BD4154FV, BD4155FV, BD4156MUV is a power management switch IC for the next generation PC card (ExpressCard™) that PCMCIA recommends. Conforms to PCMCIA's ExpressCard™ Standard, ExpressCard™ Compliance Checklist, and ExpressCard™ Implementation Guideline, and obtains the world first Compliance ID「EC10001」(BD4153FV, BD4153EFV), 「EC100040」(BD4154FV), 「EC100052」(BD4155FV) from PCMCIA. Offers various functions such as adjustable soft-starter, overcurrent detector (OC function), card detector, and system condition detector, which are ideally suited for laptop and desktop computers.

●Features

- 1) Incorporates three low on-resistance FETs for ExpressCard™.
- 2) Incorporates an FET for output discharge.
- 3) Incorporates an enabler.
- 4) Incorporates an under voltage lockout (UVLO)
- 5) Incorporates a thermal shutdown protector (TSD).
- 6) Incorporates a soft-starter.
- 7) Incorporates an over current protector (OCP).
- 8) Incorporates an over current flag output (OC).
- 9) Built-in enable signal for PLL.
- 10) Built-in Pull up resistance for detecting ExpressCard™.
- 11) Conforms to ExpressCard™ Standard.
- 12) Conforms to ExpressCard™ Compliance Checklist.
- 13) Conforms to ExpressCard™ Implementation Guideline.

●Use

Laptop and desktop computers, and other digital devices equipped with ExpressCard.

●Lineup

Parameter	BD4153FV	BD4153EFV	BD4154FV	BD4155FV	BD4156MUV
Package	SSOP-B24	HTSSOP-B24	SSOP-B20	SSOP-B20	VQFN020V4040
Soft Start	adjustable	adjustable	Fix	Fix	Fix
PERST Delay	adjustable	adjustable	Fix	Fix	Fix
OC detector	✓	✓	—	—	✓

“ExpressCard™” is a trademark registered by PCMCIA(Personal Computer Memory Card International Association).

●ABSOLUTE MAXIMUM RATINGS (Ta=25°C)

◎BD4153FV, BD4153EFV

Parameter	Symbol	BD4153FV	BD4153EFV	Unit
Power Supply Voltage	VCC	5.0 *1	5.0 *1	V
Logic Input Voltage	EN,CPPE#,CPUSB#, SYSR,PERST_IN#	5.0 *1	5.0 *1	V
Logic Output Voltage 1	OC	5.0 *1	5.0 *1	V
Logic Output Voltage 2	PERST#	VCC *1	VCC *1	V
Input Voltage 1	V3_IN, V15_IN	5.0 *1	5.0 *1	V
Input Voltage 2	V3AUX_IN	VCC *1	VCC *1	V
Output Voltage	V3,V3AUX,V15	5.0 *1	5.0 *1	V
Output current 1	IOV3, IOV15	2.0	2.0	A
Output current 2	IOV3AUX	1.0	1.0	A
Power Dissipation 1	Pd1	787 *2	-	mW
Power Dissipation 2	Pd2	1025 *3	1100 *4	mW
Operating Temperature Range	Topr	-40~+100	-40~+100	°C
Storage Temperature Range	Tstg	-55~+150	-55~+150	°C
Maximum Junction Temperature	Tjmax	+150	+150	°C

*1 However, not exceeding Pd.

*2 Pd derating at 6.3mW/°C for temperature above Ta=25°C

*3 In the case of Ta≥25°C (when mounting to 70mmx70mmx1.6mm glass epoxy substrate), derated at 8.2 mW/°C.

*4 In the case of Ta≥25°C (when mounting to 70mmx70mmx1.6mm glass epoxy substrate), derated at 8.8 mW/°C.

●OPERATING CONDITIONS (Ta=25°C)

◎BD4153FV, BD4153EFV

Parameter	Symbol	MIN	MAX	Unit
Power Supply Voltage	VCC	3.0	3.6	V
Logic Input Voltage 1	EN	-0.2	3.6	V
Logic Input Voltage 2	CPPE#,CPUSB#, SYSR,PERST_IN#	-0.2	VCC	V
Logic Output Voltage 1	OC	-	3.6	V
Logic Output Voltage 2	PERST#	-	VCC	V
Input Voltage 1	V3_IN	3.0	3.6	V
Input Voltage 2	V3AUX_IN	3.0	VCC	V
Input Voltage 3	V15_IN	1.35	1.65	V
Soft Start Setup Capacitor 1	CSS_V3, CSS_V15	0.001	1.0	μF
Soft Start Setup Capacitor 2	CSS_V3AUX	0.001	0.1	μF

★ This product is designed for protection against radioactive rays.

●ABSOLUTE MAXIMUM RATINGS (Ta=25°C)

◎BD4154FV

Parameter	Symbol	Limit	Unit
Input Voltage	V3AUX_IN, V3_IN, V15_IN	-0.3~5.0 * ⁵	V
Logic Input Voltage 1	EN, CPPE#, CPUSB#, SYSR, PERST_IN#, RCLKEN	-0.3~V3AUX_IN+0.3 * ⁵	V
Logic Output Voltage 1	RCLKEN	-0.3~V3AUX_IN+0.3 * ⁵	V
Logic Output Voltage 2	PERST#	-0.3~V3AUX_IN+0.3	V
Output Voltage	V3AUX, V3, V15	-0.3~5.0 * ⁵	V
Output Current 1	IOV3AUX	1.0	A
Output Current 2	IOV3	2.0	A
Output Current 3	IOV15	2.0	A
Power Dissipation 1	Pd1	500.0 * ⁶	mW
Power Dissipation 2	Pd2	812.5 * ⁷	mW
Operating Temperature Range	Topr	-40~+100	°C
Storage Temperature Range	Tstg	-55~+150	°C
Maximum Junction Temperature	Tjmax	+150	°C

*⁵ Not to exceed Pd.

*⁶ Reduced by 4.0mW for each increase in Ta of 1°C over 25°C

*⁷ Reduced by 6.5mW for each increase in Ta of 1°C over 25°C (When mounted on a board 70mm×70mm×1.6mm Glass-epoxy PCB)

●OPERATING CONDITIONS (Ta=25°C)

◎BD4154FV

Parameter	Symbol	MIN	MAX	Unit
Input Voltage 1	V3AUX_IN	3.0	3.6	V
Input Voltage 2	V3_IN	3.0	3.6	V
Input Voltage 3	V15_IN	1.35	1.65	V
Logic Input Voltage 1	EN	-0.3	3.6	V
Logic Input Voltage 2	CPPE#, CPUSB#, SYSR, PERST_IN#, RCLKEN	0	V3AUX_IN	V
Logic Output Voltage 1	RCLKEN	0	V3AUX_IN	V
Logic Output Voltage 2	PERST#	0	V3AUX_IN	V
Output Current 1	IOV3AUX	0	275	mA
Output Current 2	IOV3	0	1.3	A
Output Current 3	IOV15	0	650	mA

★ This product is not designed to offer protection against radioactive rays.

●ABSOLUTE MAXIMUM RATINGS (Ta=25°C)

◎BD4155FV

Parameter	Symbol	Limit	Unit
Input Voltage	V3AUX_IN, V3_IN, V15_IN	-0.3~+5.0 * ⁸	V
Logic Input Voltage	CPPE#,CPUSB#,SYSR,EC_CLKREQ#, EC_CLKEN#,EC_RST#,PLT_RST#	-0.3~V3AUX_IN+0.3 * ⁸	V
Logic Output Voltage	PERST#	-0.3~V3AUX_IN+0.3	V
Logic Output applied Voltage	PLL_CLKREQ#	-0.3~+5.0	V
Output Voltage	V3AUX,V3, V15	-0.3~+5.0 * ⁸	V
Output current 1	IOV3AUX	1.0	A
Output current 2	IOV3	2.0	A
Output current 3	IOV15	2.0	A
Power Dissipation 1	Pd1	500 * ⁹	mW
Power Dissipation 2	Pd2	812.5 * ¹⁰	mW
Operating Temperature Range	Topr	-40~+100	°C
Storage Temperature Range	Tstg	-55~+150	°C
Maximum Junction Temperature	Tjmax	+150	°C

*⁸ Not to exceed Pd.

*⁹ Reduced by 4.0mW for each increase in Ta of 1°C over 25°C

*¹⁰ Reduced by 6.5mW for each increase in Ta of 1°C over 25°C (When mounted on a board 70mm×70mm×1.6mm Glass-epoxy PCB) .

●OPERATING CONDITIONS (Ta=25°C)

◎BD4155FV

Parameter	Symbol	MIN	MAX	Unit
Input Voltage 1	V3AUX_IN	3.0	3.6	V
Input Voltage 2	V3_IN	3.0	3.6	V
Input Voltage 3	V15_IN	1.35	1.65	V
Logic Input Voltage	CPPE#,CPUSB#,SYSR,EC_CLKREQ#, EC_CLKEN#,EC_RST#,PLT_RST#	0	V3AUX_IN	V
Logic Output Voltage 1	PERST#	0	V3AUX_IN	V
Logic Output Voltage 2	PLL_CLKREQ#	0	3.6	V
Output current 1	IOV3AUX	0	275	mA
Output current 2	IOV3	0	1.3	A
Output current 3	IOV15	0	650	mA

★ This product is not designed to offer protection against radioactive rays.

●ABSOLUTE MAXIMUM RATINGS (Ta=25°C)

◎BD4156MUV

Parameter	Symbol	Limit	Unit
Input Voltage	V3AUX_IN, V3_IN, V15_IN	-0.3~5.0 *11	V
Logic Input Voltage 1	EN, CPPE#, CPUSB#, SYSR, PERST_IN#, RCLKEN	-0.3~V3AUX_IN+0.3 *11	V
Logic Output Voltage 1	RCLKEN	-0.3~V3AUX_IN+0.3 *11	V
Logic Output Voltage 2	PERST#	-0.3~V3AUX_IN+0.3	V
Logic Output Voltage 3	OC#	-0.3~5.0	V
Output Voltage	V3AUX, V3, V15	-0.3~5.0 *11	V
Output Current 1	IOV3AUX	1.0	A
Output Current 2	IOV3	2.0	A
Output Current 3	IOV15	2.0	A
Power Dissipation 1	Pd1	0.34 *12	W
Power Dissipation 2	Pd2	0.70 *13	W
Operating Temperature Range	Topr	-40~+100	°C
Storage Temperature Range	Tstg	-55~+150	°C
Maximum Junction Temperature	Tjmax	+150	°C

*11 Not to exceed Pd.

*12 Reduced by 2.7mW for each increase in Ta of 1°C over 25°C

*13 Reduced by 5.6mW for each increase in Ta of 1°C over 25°C (When mounted on a board 70mm×70mm×1.6mm Glass-epoxy PCB) .

●OPERATING CONDITIONS (Ta=25°C)

◎BD4156MUV

Parameter	Symbol	MIN	MAX	Unit
Input Voltage 1	V3AUX_IN	3.0	3.6	V
Input Voltage 2	V3_IN	3.0	3.6	V
Input Voltage 3	V15_IN	1.35	1.65	V
Logic Input Voltage 1	EN	-0.3	3.6	V
Logic Input Voltage 2	CPPE#, CPUSB#, SYSR, PERST_IN#, RCLKEN	0	V3AUX_IN	V
Logic Output Voltage 1	RCLKEN	0	V3AUX_IN	V
Logic Output Voltage 2	PERST#	0	V3AUX_IN	V
Logic Output Voltage 3	OC#	0	3.6	V
Output Current 1	IOV3AUX	0	275	mA
Output Current 2	IOV3	0	1.3	A
Output Current 3	IOV15	0	650	mA

★ This product is not designed to offer protection against radioactive rays.

●ELECTRICAL CHARACTERISTICS (BD4153FV, BD4153EFV)

(unless otherwise noted, Ta=25°C VCC=3.3V VEN=3.3V V3_IN=V3AUX_IN=3.3V,V15_IN=1.5V)

Parameter	Symbol	Standard Value			Unit	Condition
		MIN	TYP	MAX		
Standby current	IST	-	35	70	μA	VEN=0V
Bias current 1	Icc1	-	0.25	0.50	mA	VSYSR=0V
Bias current 2	Icc2	-	1.0	2.0	mA	VSYSR=3.3V
[Enable]						
High Level Enable Input Voltage	VENHI	2.3	-	5.5	V	
Low Level Enable Input Voltage	VENLOW	-0.2	-	0.8	V	
Enable Pin Input current	IEN	-	3	10	μA	VEN=3V
[Logic (CPPE#,CPUSB#)]						
High Level Logic Input Voltage	VLHI	2.3	-	VCC	V	
Low Level Logic Input Voltage	VLOW	-0.2	-	0.8	V	
Logic Pin Input current	IL	-1	0	1	μA	V _{CPPE#} =3.3V or V _{CPUSB#} =3.3V
[Logic (SYSR)]						
High Level Logic Input Voltage	VSYSRHI	2.3	-	VCC	V	
Low Level Logic Input Voltage	VSYSRLOW	-0.2	-	0.8	V	
Logic Pin Input current	ISYSR	6	11	18	μA	V _{SYSR} =3.3V
[Logic (PERST_IN#)]						
High Level Logic Input Voltage	VPSTHI	2.3	-	VCC	V	
Low Level Logic Input Voltage	VPSTLOW	-0.2	-	0.8	V	
Logic Pin Input current	IPST	-18	-11	-6	μA	V _{PERST_IN#} =0V
[Switch V3]						
On Resistance	R _{V3}	-	35	73	mΩ	Tj=-10~100°C *
Discharge On Resistance	R _{V3Dis}	-	60	150	Ω	
[Switch V3AUX]						
On Resistance	R _{V3AUX}	-	100	210	mΩ	Tj=-10~100°C *
Discharge On Resistance	R _{V3AUXDis}	-	60	150	Ω	
[Switch V15]						
On Resistance	R _{V15}	-	42	85	mΩ	Tj=-10~100°C *
Discharge On Resistance	R _{V15Dis}	-	60	150	Ω	
[Soft Start]						
Charge current	Ichr	1.0	2.0	3.0	μA	
SS_V3 High Voltage	SS_V3high	V3+4	V3+5	V3+6	V	
SS_V15 High Voltage	SS_V15high	V15+4	V15+5	V15+6	V	
SS_V3AUX High Voltage	SS_AUXhigh	1.5	1.8	2.1	V	
Discharge current	IDis	0.3	1.0	-	mA	V _{SS} =1V
Low Voltage	SSLOW	-	-	50	mV	
[Over Current Protection]						
OC Flag V3	OCPV3_S	1.0	-	-	A	
V3 Over current	OCPV3	2.0	-	-	A	
OC Flag V3AUX	OCPV3AUX_S	0.25	-	-	A	
V3AUX Over current	OCPV3AUX	0.50	-	-	A	
OC Flag V15	OCPV15_S	0.50	-	-	A	
V15 Over current	OCPV15	1.20	-	-	A	
OC_Delay Charge current	I _{OCP_Delaych}	1.0	2.0	3.0	μA	
OC_Delay Discharge current	I _{OCP_Delaydis}	1.0	2.0	-	mA	VOC_DELAY=1V
OC_Delay Standby Voltage	VOCP_Delayst	-	-	50	mV	
OC_Delay Threshold Voltage	VOCP_Delayth	0.6	0.7	0.8	V	
OC Low Voltage	VOCP	-	0.1	0.2	V	IOC=0.5mA
OC Leak current	IOCP	-	-	1	μA	VOC=3.65V
[Under Voltage Lockout]						
V3_IN UVLO OFF Voltage	VUVLOV3_IN	2.80	2.90	3.00	V	sweep up
V3_IN Hysteresis Voltage	ΔVUVLOV3_IN	80	160	240	mV	sweep down
V3AUX_IN UVLO OFF Voltage	VUVLOV3AUX_IN	2.80	2.90	3.00	V	sweep up
V3AUX_IN Hysteresis Voltage	ΔVUVLOV3AUX_IN	80	160	240	mV	sweep down
V15 UVLO OFF Voltage	VUVLOV15	1.25	1.30	1.35	V	sweep up
V15 Hysteresis Voltage	ΔVUVLOV15	50	100	150	mV	sweep down
VCC UVLO OFF Voltage	VUVLOVCC	2.80	2.90	3.00	V	sweep up
VCC Hysteresis Voltage	ΔVUVLOVCC	80	160	240	mV	sweep down

* Design Guarantee

● ELECTRICAL CHARACTERISTICS (BD4154FV)
(unless otherwise noted, Ta=25°C VEN=3.3V V3AUX_IN =V3_IN=3.3V,V15_IN=1.5V)

Parameter	Symbol	Standard Value			Unit	Condition	
		MIN	TYP	MAX			
Standby Current	IST	-	40	80	uA	VEN=0V (Include IEN, IRCLKEN)	
Bias Current 1	Icc1	-	120	250	uA	VSYSR=0V	
Bias Current 2	Icc2	-	250	500	uA	VSYSR=3.3V	
[Enable]							
High Level Enable Input Voltage	VENHI	2.0	-	5.5	V		
Low Level Enable Input Voltage	VENLOW	-0.2	-	0.8	V		
Enable Pin Input Current	IEN	10	-	30	uA	VEN=0V	
[Logic]							
High Level Logic Input Voltage	VLHI	2.0	-	-	V		
Low Level Logic Input Voltage	VLOW	-	-	0.8	V		
Logic Pin Input Current	ICPPE#	-	0	1	uA	CPPE#=3.6V	
		10	-	30	uA	CPPE#=0V	
	ICPUSB#	-	0	1	uA	CPUSB#=3.6V	
		10	-	30	uA	CPUSB#=0V	
	ISYSR	-	0	1	uA	SYSR=3.6V	
		10	-	30	uA	SYSR=0V	
	IPRT_IN#	-	0	1	uA	PERST_IN#=3.6V	
		10	-	30	uA	PERST_IN#=0V	
	IRCLKEN	-	0	1	uA	RCLKEN=3.6V	
		10	-	30	uA	RCLKEN=0V	
	RCLKEN Low Voltage	VRCLKEN	-	0.1	0.3	V	IRCLKEN=0.5mA
	RCLKEN Leak Current	IRCLKEN	-	-	1	uA	VRCLKEN=3.65V
[Switch V3AUX]							
On Resistance	R _{V3AUX}	-	120	220	mΩ	Tj=-10~100°C *	
Discharge On Resistance	R _{V3AUX Dis}	-	60	150	Ω		
[Switch V3]							
On Resistance	R _{V3}	-	42	90	mΩ	Tj=-10~100°C *	
Discharge On Resistance	R _{V3Dis}	-	60	150	Ω		
[Switch V15]							
On Resistance	R _{V15}	-	45	90	mΩ	Tj=-10~100°C *	
Discharge On Resistance	R _{V15Dis}	-	60	150	Ω		
[Over Current Protection]							
V3 Over Current	OCP _{V3}	1.3	-	-	A		
V3AUX Over Current	OCP _{V3AUX}	0.275	-	-	A		
V15 Over Current	OCP _{V15}	0.65	-	-	A		
[Under Voltage Lockout]							
V3_IN UVLO OFF Voltage	VUVLO _{V3_IN}	2.70	2.80	2.90	V	sweep up	
V3_IN Hysteresis Voltage	ΔVUVLO _{V3_IN}	50	100	150	mV	sweep down	
V3AUX_IN UVLO OFF Voltage	VUVLO _{V3AUX_IN}	2.70	2.80	2.90	V	sweep up	
V3AUX_IN Hysteresis Voltage	ΔVUVLO _{V3AUX_IN}	50	100	150	mV	sweep down	
V15_IN UVLO OFF Voltage	VUVLO _{V15_IN}	1.15	1.20	1.25	V	sweep up	
V15_IN Hysteresis Voltage	ΔVUVLO _{V15_IN}	50	100	150	mV	sweep down	
[POWER GOOD]							
V3 POWER GOOD Voltage	PG _{V3}	2.700	2.850	3.000	V		
V3AUX POWER GOOD Voltage	PG _{V3AUX}	2.700	2.850	3.000	V		
V15 POWER GOOD Voltage	PG _{V15}	1.200	1.275	1.350	V		
PERST# LOW Voltage	VPERST# _{LOW}	-	0.1	0.3	V	I _{PERST} =0.5mA	
PERST# HIGH Voltage	VPERST# _{HIGH}	3.0	-	-	V		
PERST# Delay Time	T _{PERST#}	4	-	20	ms		
PERST# assertion time	T _{ast}	-	-	500	ns		
[OUTPUT RISE TIME]							
V3_IN to V3	T _{V3}	0.1	-	3	ms		
V3AUX_IN to V3AUX	T _{V3AUX}	0.1	-	3	ms		
V15_IN to V15	T _{V15}	0.1	-	3	ms		

* Design Guarantee

● ELECTRICAL CHARACTERISTICS (BD4155FV)

(unless otherwise noted, Ta=25°C V3AUX_IN =V3_IN=3.3V,V15_IN=1.5V)

Parameter	Symbol	Standard Value			Unit	Condition
		MIN	TYP	MAX		
Standby current	Icc1	-	120	250	uA	VSYSR=0V
Bias current	Icc2	-	250	500	uA	VSYSR=3.3V
[Logic]						
High Level Enable Input Voltage	VL _{HI}	2.0	-	-	V	
Low Level Enable Input Voltage	VL _{LOW}	-	-	0.8	V	
Input current	ICPPE#	-	0	1	uA	CPPE#=3.6V
		10	-	30	uA	CPPE#=0V
	ICPUSB#	-	0	1	uA	CPUSB#=3.6V
		10	-	30	uA	CPUSB#=0V
	ISYSR	-1	0	1	uA	SYSR=3.6V
	IEC_CLKEN#	5	0	20	uA	EC_CLKEN#=3.6V
	IEC_CLKREQ#	-1	0	1	uA	EC_CLKREQ#=3.6V
	IEC_RST#	-1	0	1	uA	EC_RST#=3.6V
IPLT_RST#	-1	0	1	uA	PLT_RST#=3.6V	
[Switch V3AUX]						
On Resistance	R _{V3AUX}	-	120	220	mΩ	Tj=-10~100°C *
Discharge On Resistance	R _{V3AUXDis}	-	60	150	Ω	
[Switch V3]						
On Resistance	R _{V3}	-	42	90	mΩ	Tj=-10~100°C *
Discharge On Resistance	R _{V3Dis}	-	60	150	Ω	
[Switch V15]						
On Resistance	R _{V15}	-	45	90	mΩ	Tj=-10~100°C *
Discharge On Resistance	R _{V15Dis}	-	60	150	Ω	
[Over Current Protection]						
V3 Over current	OCP _{V3}	1.6	-	-	A	
V3AUX Over current	OCP _{V3AUX}	0.35	-	-	A	
V15 Over current	OCP _{V15}	0.8	-	-	A	
[Low input miss operation prevent Block]						
V3_IN threshold voltage	VUVLO _{V3_IN}	2.70	2.80	2.90	V	sweep up
V3_IN hysteresis Voltage	ΔVUVLO _{V3_IN}	50	100	150	mV	sweep down
V3AUX_IN threshold voltage	VUVLO _{V3AUX_IN}	2.70	2.80	2.90	V	sweep up
V3AUX_IN hysteresis Voltage	ΔVUVLO _{V3AUX_IN}	50	100	150	mV	sweep down
V15_IN threshold voltage	VUVLO _{V15_IN}	1.15	1.20	1.25	V	sweep up
V15_IN hysteresis Voltage	ΔVUVLO _{V15_IN}	50	100	150	mV	sweep down
[POWER GOOD]						
V3 POWER GOOD Voltage	PG _{V3}	2.700	2.850	3.000	V	
V3AUX POWER GOOD Voltage	PG _{V3AUX}	2.700	2.850	3.000	V	
V15 POWER GOOD Voltage	PG _{V15}	1.200	1.275	1.350	V	
PERST# LOW Voltage	VPERST# _{LOW}	-	0.1	0.3	V	I _{PERST} =0.5mA
PERST# HIGH Voltage	VPERST# _{HIGH}	3.0	-	-	V	
PERST Delay	T _{PERST#}	4	10	20	ms	
PLL_CLKREQ# Low Voltage	V _{PLL}	-	0.1	0.2	V	I _{PLL_CLKREQ#} =0.5mA
PLL_CLKREQ# Leak Current	I _{PLL}	-	-	1	uA	V _{PLL_CLKREQ#} =3.6V
[WAKE UP TIME]						
V3_IN to V3	T _{V3}	0.1	-	3	ms	
V3AUX_IN to V3AUX	T _{V3AUX}	0.1	-	3	ms	
V15_IN to V15	T _{V15}	0.1	-	3	ms	

* Design Guarantee

● ELECTRICAL CHARACTERISTICS (BD4156MUV)

(unless otherwise noted, Ta=25°C VEN=3.3V V3AUX_IN =V3_IN=3.3V,V15_IN=1.5V)

Parameter	Symbol	Standard Value			Unit	Condition
		MIN	TYP	MAX		
Standby Current	IST	-	40	80	uA	VEN=0V (Include IEN, IRCLKEN)
Bias Current 1	Icc1	-	120	250	uA	VSYSR=0V
Bias Current 2	Icc2	-	250	500	uA	VSYSR=3.3V
[Enable]						
High Level Enable Input Voltage	VENHI	2.0	-	5.5	V	
Low Level Enable Input Voltage	VENLOW	-0.2	-	0.8	V	
Enable Pin Input Current	IEN	10	-	30	uA	VEN=0V
[Logic]						
High Level Logic Input Voltage	VLHI	2.0	-	-	V	
Low Level Logic Input Voltage	VLLOW	-	-	0.8	V	
Logic Pin Input Current	ICPPE#	-	0	1	uA	CPPE#=3.6V
		10	-	30	uA	CPPE#=0V
	ICPUSB#	-	0	1	uA	CPUSB#=3.6V
		10	-	30	uA	CPUSB#=0V
	ISYSR	-	0	1	uA	SYSR=3.6V
		10	-	30	uA	SYSR=0V
	IPRT_IN#	-	0	1	uA	PERST_IN#=3.6V
		10	-	30	uA	PERST_IN#=0V
IRCLKEN	-	0	1	uA	RCLKEN=3.6V	
	10	-	30	uA	RCLKEN=0V	
RCLKEN Low Voltage	VRCLKEN	-	0.1	0.3	V	IRCLKEN=0.5mA
RCLKEN Leak Current	IRCLKEN	-	-	1	uA	VRCLKEN=3.65V
[Switch V3AUX]						
On Resistance	R _{V3AUX}	-	120	220	mΩ	Tj=-10~100°C *
Discharge On Resistance	R _{V3AUX Dis}	-	60	150	Ω	
[Switch V3]						
On Resistance	R _{V3}	-	42	90	mΩ	Tj=-10~100°C *
Discharge On Resistance	R _{V3 Dis}	-	60	150	Ω	
[Switch V15]						
On Resistance	R _{V15}	-	45	90	mΩ	Tj=-10~100°C *
Discharge On Resistance	R _{V15 Dis}	-	60	150	Ω	
[Over Current Protection]						
OC flag V3 Current	OC _{V3}	1.0	-	-	A	
V3 Over Current	OC _{PV3}	1.3	-	-	A	
OC flag V3AUX Current	OC _{V3AUX}	0.25	-	-	A	
V3AUX Over Current	OC _{PV3AUX}	0.275	-	-	A	
OC flag V15 Current	OC _{V15}	0.5	-	-	A	
V15 Over Current	OC _{PV15}	0.65	-	-	A	
OC delay time	T _{OC#}	4	-	20	ms	
[Under Voltage Lockout]						
V3_IN UVLO OFF Voltage	VUVLO _{V3_IN}	2.70	2.80	2.90	V	sweep up
V3_IN Hysteresis Voltage	ΔVUVLO _{V3_IN}	50	100	150	mV	sweep down
V3AUX_IN UVLO OFF Voltage	VUVLO _{V3AUX_IN}	2.70	2.80	2.90	V	sweep up
V3AUX_IN Hysteresis Voltage	ΔVUVLO _{V3AUX_IN}	50	100	150	mV	sweep down
V15_IN UVLO OFF Voltage	VUVLO _{V15_IN}	1.15	1.20	1.25	V	sweep up
V15_IN Hysteresis Voltage	ΔVUVLO _{V15_IN}	50	100	150	mV	sweep down
[POWER GOOD]						
V3 POWER GOOD Voltage	PG _{V3}	2.700	2.850	3.000	V	
V3AUX POWER GOOD Voltage	PG _{V3AUX}	2.700	2.850	3.000	V	
V15 POWER GOOD Voltage	PG _{V15}	1.200	1.275	1.350	V	
PERST# LOW Voltage	VPERST# _{LOW}	-	0.1	0.3	V	I _{PERST} =0.5mA
PERST# HIGH Voltage	VPERST# _{HIGH}	3.0	-	-	V	
PERST# Delay Time	T _{PERST#}	4	-	20	ms	
PERST# assertion time	T _{ast}	-	-	500	ns	
[OUTPUT RISE TIME]						
V3_IN to V3	T _{V3}	0.1	-	3	ms	
V3AUX_IN to V3AUX	T _{V3AUX}	0.1	-	3	ms	
V15_IN to V15	T _{V15}	0.1	-	3	ms	

* Design Guarantee

● Reference data

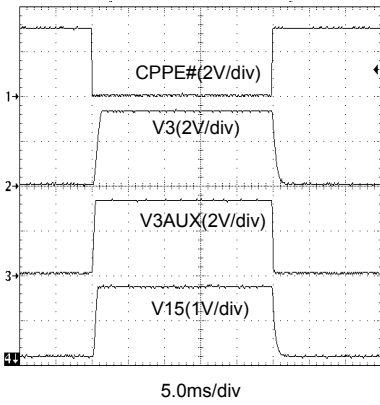

Fig.1 Card Assert/ De-assert (Active)

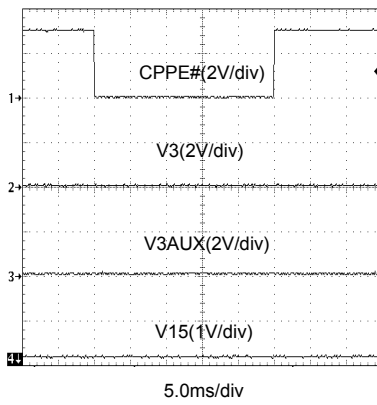

Fig.2 Card Assert/De-assert (Standby)

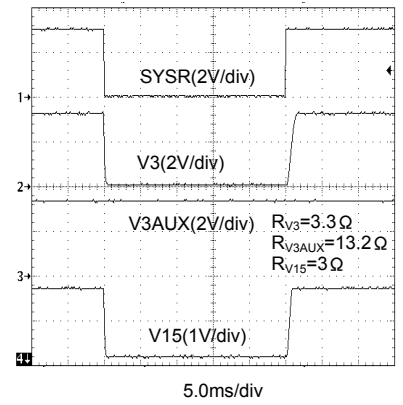

Fig.3 System Active ⇔ Standby (Card Present)

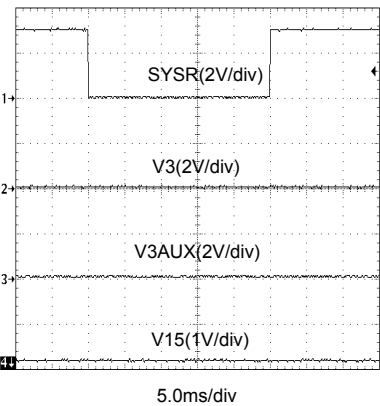

Fig.4 System Active ⇔ Standby (No Card)

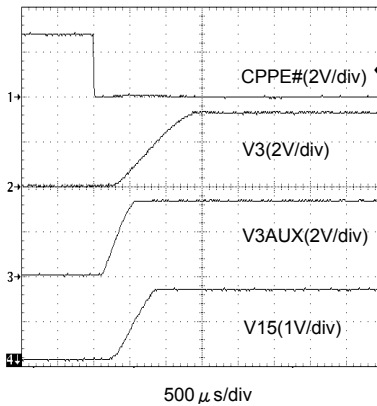

Fig.5 Wakeup Wave Form (Card Assert)

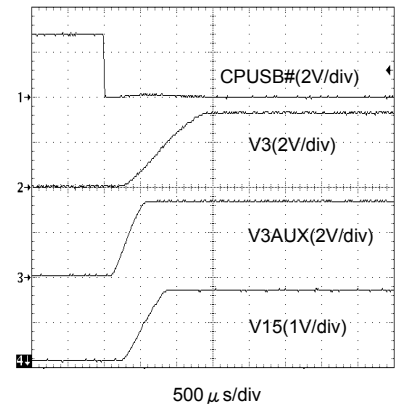

Fig.6 Wakeup Wave Form (USB2.0 Assert)

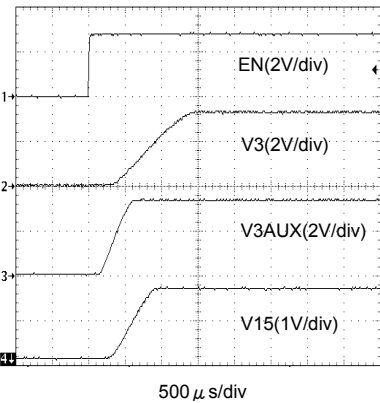

Fig.7 Wakeup Wave Form (Shut Down → Active)

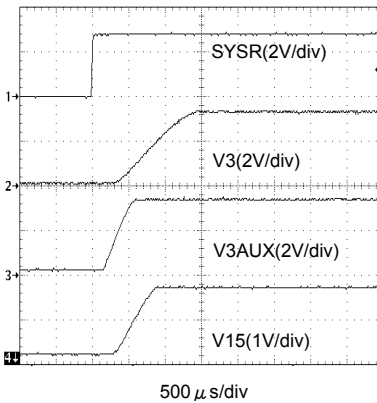

Fig.8 Wakeup Wave Form (Standby → Active)

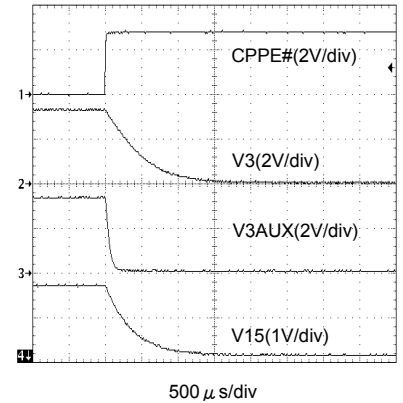

Fig.9 Power Down Wave Form (Card De-assert)

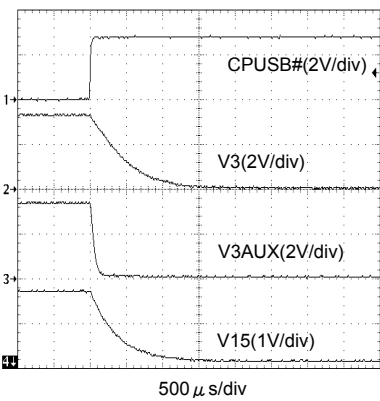

Fig.10 Power Down Wave Form (USB2.0 De-assert)

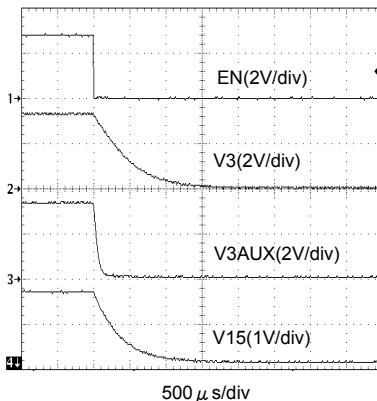

Fig.11 Power Down Wave Form (Active → Shut Down)

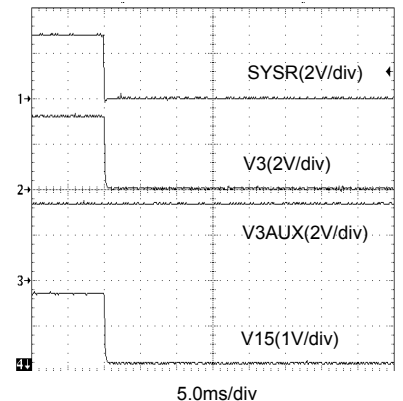

Fig.12 Power Down Wave Form (Active → Standby)

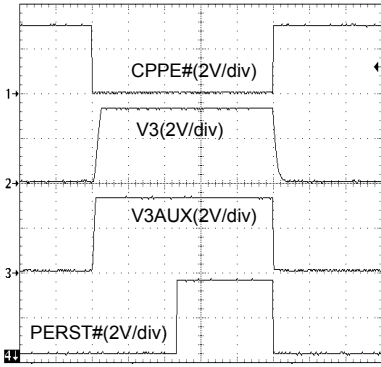

Fig.13 PERST# Wave Form
(Card Assert/ De-assert)

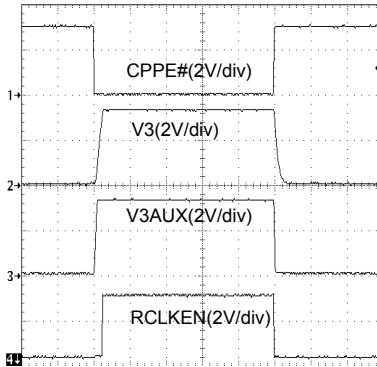

Fig.14 RCLKEN Wave Form
(Card Assert/ De-assert)
(BD4154FV, BD4156MUV)

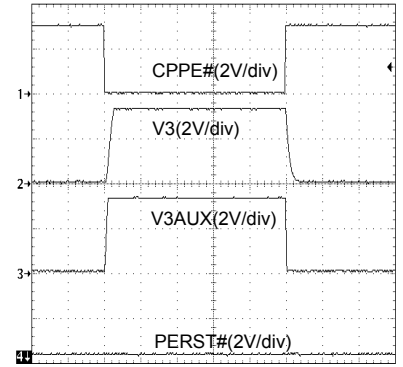

Fig.15 PERST# Wave Form
(USB2.0 Assert/ De-assert)

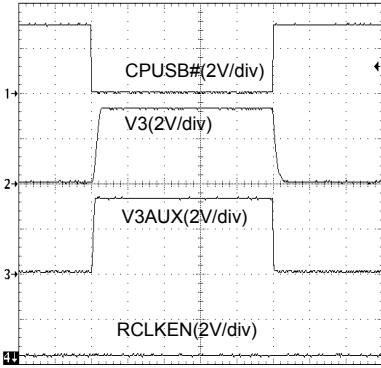

Fig.16 RCLKEN Wave Form
(USB2.0 Assert/ De-assert)
(BD4154FV, BD4156MUV)

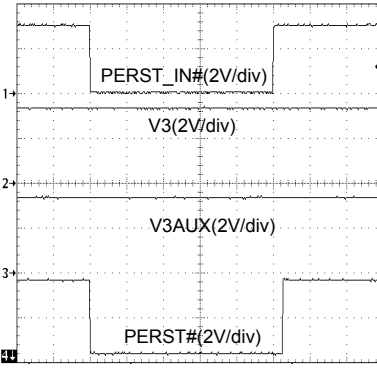

Fig.17 PERST# Wave Form
(PERST_IN# Input)
(BD4153FV, BD4153EFV, BD4154FV, BD4156MUV)

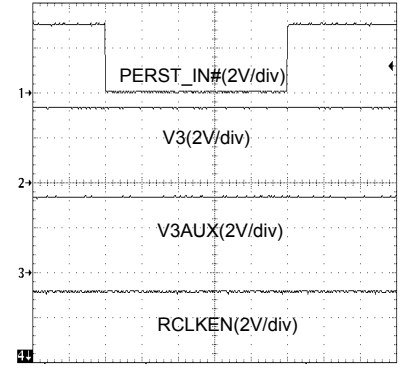

Fig.18 RCLKEN Wave Form
(PERST_IN# Input)
(BD4154FV, BD4156MUV)

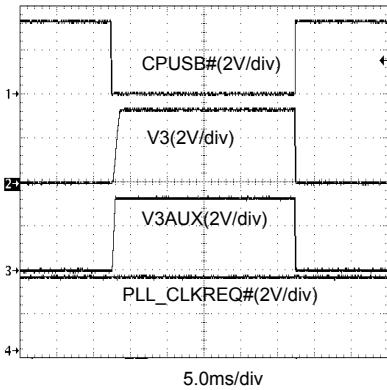

Fig.19 PLL_CLKREQ# Wave Form
(USB2.0 Assert/ De-assert)
(BD4155FV)

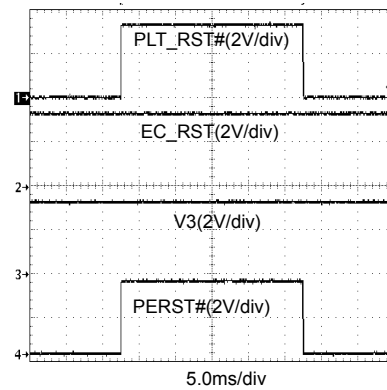

Fig.20 PERST# Wave Form
(PLT_RST Input)
(BD4155FV)

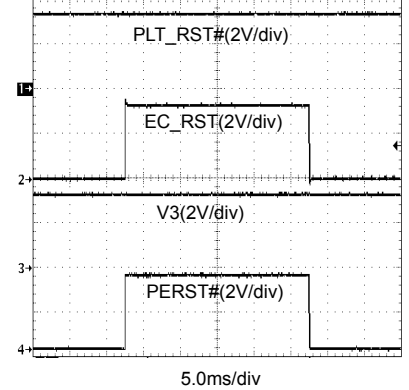

Fig.21 PERST# Wave Form
(EC_RST Input)
(BD4155FV)

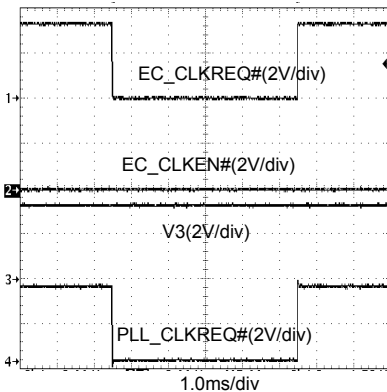

Fig.22 PLL_CLKREQ# Wave Form
(EC_CLKREQ# Input)
(BD4155FV)

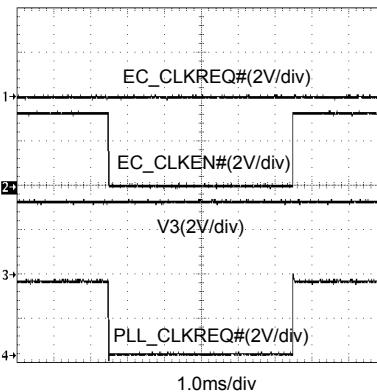

Fig.23 PLL_CLKREQ# Wave Form
(EC_CLKEN# Input)
(BD4155FV)

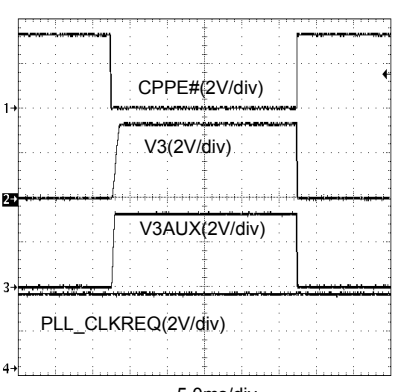
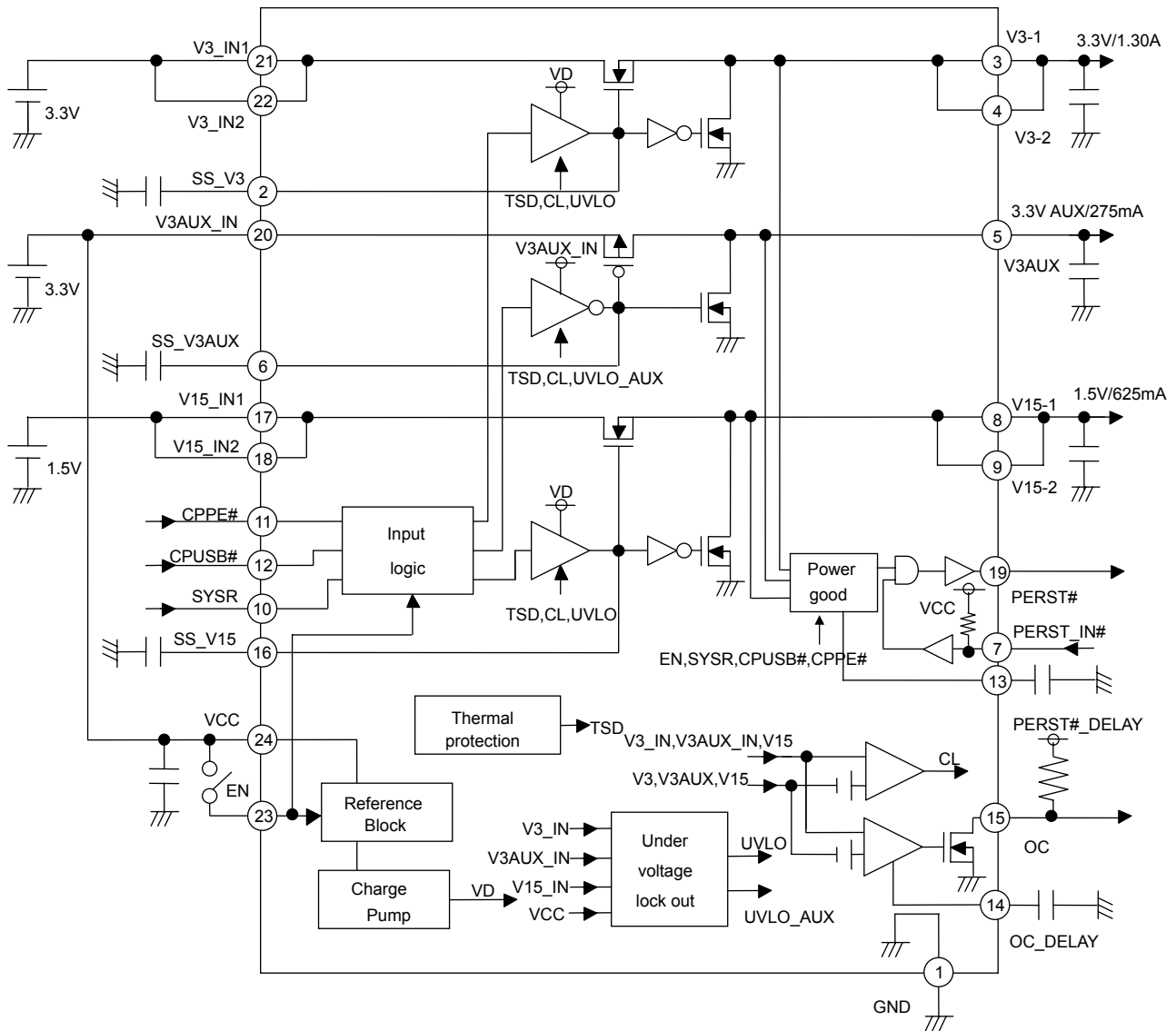
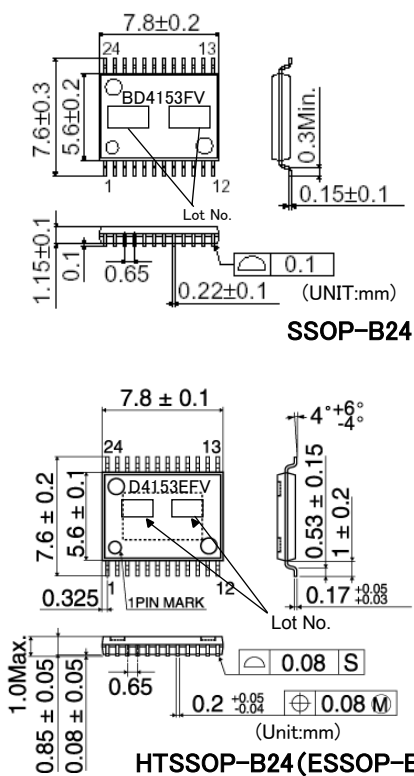

Fig.24 PLL_CLKREQ# Wave Form
(EC_CLKEN# Input)
(BD4155FV)

●BLOCK DIAGRAM (BD4153FV, BD4153EFV)



●PHYSICAL DIMENSIONS



●PIN FUNCTION

PIN No	PIN NAME	PIN FUNCTION
1	GND	GND pin
2	SS_V3	V3 soft start pin
3	V3_1	V3 output pin 1
4	V3_2	V3 output pin 2
5	V3AUX	V3AUX output pin
6	SS_V3AUX	V3AUX soft start pin
7	PERST_IN#	PERST# control input pin (SysReset#)
8	V15_1	V15 output pin 1
10	V15_2	V15 output pin 2
11	YSR	Logic input pin
	CPPE#	Logic input pin
12	CPUSB#	Logic input pin
13	PERST#_DELAY	PERST# delay time setting pin
14	OC_DELAY	OC delay time setting pin
15	OC	over current protect signal output pin
16	SS_V15	V15 soft start pin
17	V15_IN1	V15 input pin 1
18	V15_IN2	V15 input pin 2
19	PERST#	Logic output pin
20	V3AUX_IN	V3AUX input pin 1
21	V3_IN1	V3 input pin 1
22	V3_IN2	V3 input pin 2
23	EN	Enable input pin
24	VCC	Input voltage

●BLOCK DIAGRAM (BD4154FV)

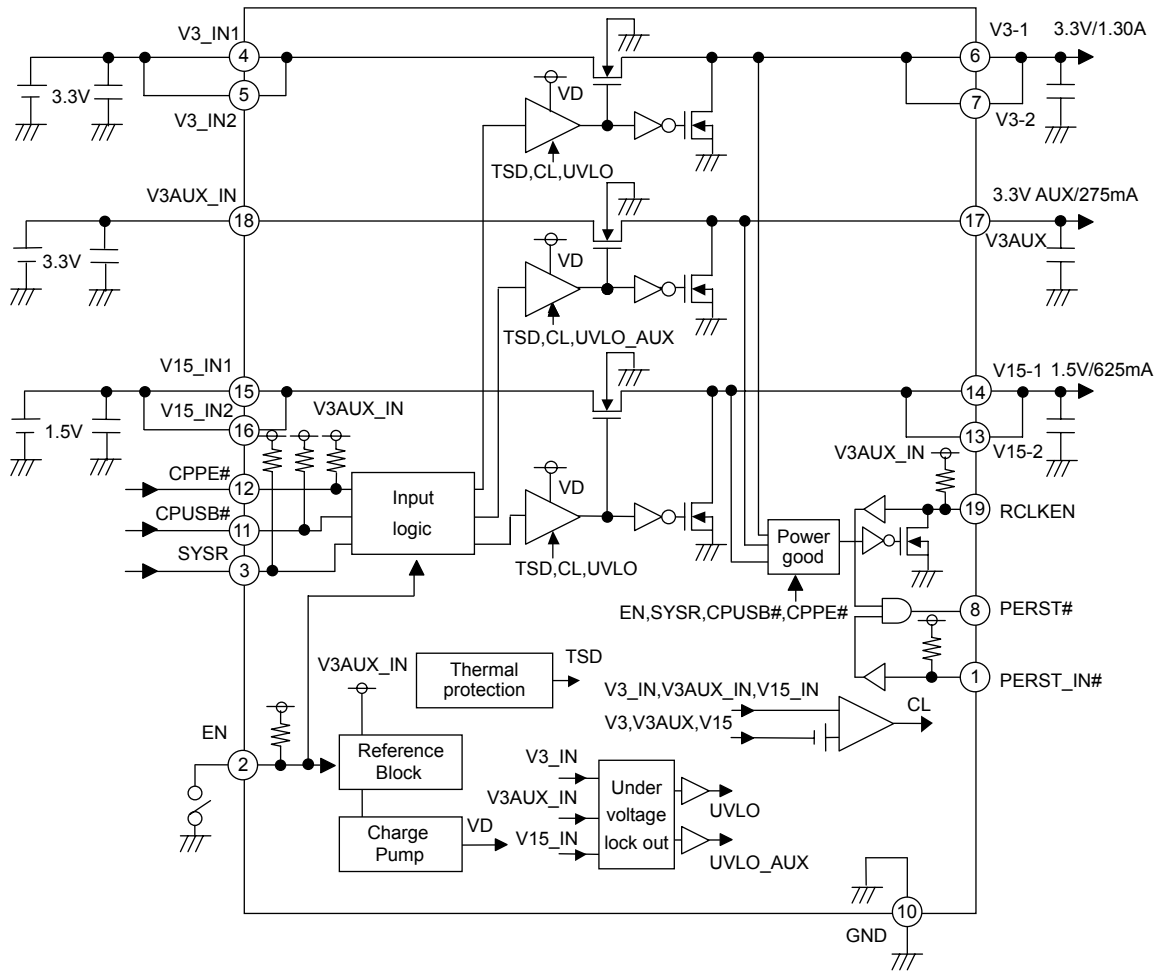

●PHYSICAL DIMENSIONS

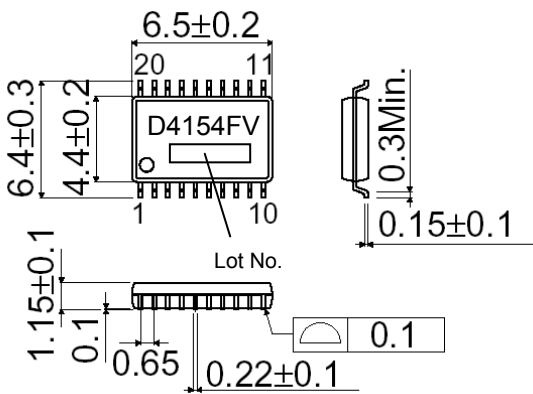

SSOP-B20 (Unit:mm)

●PIN FUNCTION

PIN No	PIN NAME	PIN FUNCTION
1	PERST_IN#	PERST# control input pin (SysReset#)
2	EN	Enable input pin
3	SYSR	Logic input pin
4	V3_IN1	V3 input pin 1
5	V3_IN2	V3 input pin 2
6	V3_1	V3 output pin 1
7	V3_2	V3 output pin 2
8	PERST#	Logic output pin
9	TEST	Test pin
10	GND	GND pin
11	CPUSB#	Logic input pin
12	CPPE#	Logic input pin
13	V15_1	V15 output pin 1
14	V15_2	V15 output pin 2
15	V15_IN1	V15 input pin 1
16	V15_IN2	V15 input pin 2
17	V3AUX	V3AUX output pin
18	V3AUX_IN	V3AUX input pin 1
19	RCLKEN	Reference clock enable signal / Power good signal (No delay)
20	NC	Non connection

●BLOCK DIAGRAM (BD4155FV)

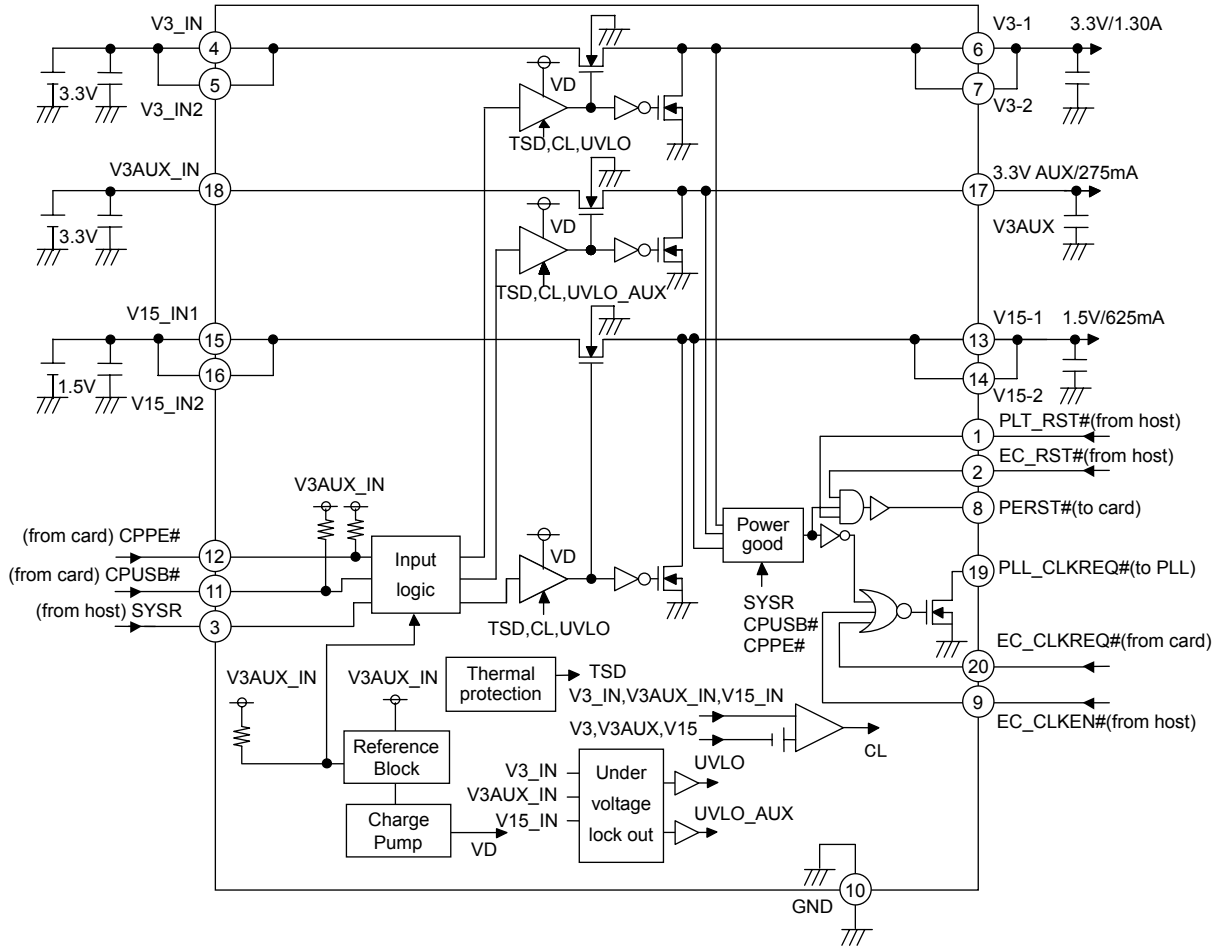

●PHYSICAL DIMENSIONS

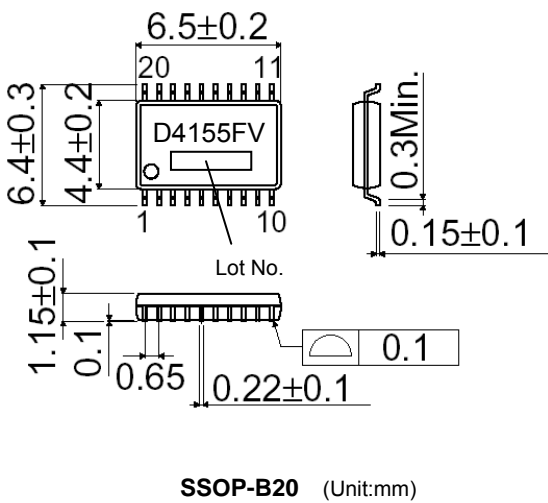

●PIN FUNCTION

PIN No	PIN NAME	PIN FUNCTION
1	PLT_RST#	Logic input pin (from HOST)
2	EC_RST#	Logic input pin (from HOST)
3	SYSR	Logic input pin
4	V3_IN1	V3 input pin 1
5	V3_IN2	V3 input pin 2
6	V3_1	V3 output pin 1
7	V3_2	V3 output pin 2
8	PERST#	Logic output pin
9	EC_CLKEN#	Logic input pin (from HOST)
10	GND	GND pin
11	CPUSB#	Logic input pin
12	CPPE#	Logic input pin
13	V15_1	V15 output pin 1
14	V15_2	V15 output pin 2
15	V15_IN1	V15 input pin 1
16	V15_IN2	V15 input pin 2
17	V3AUX	V3AUX output pin
18	V3AUX_IN	V3AUX input pin 1
19	PLL_CLKREQ#	Clock enable signal (to PLL)
20	EC_CLKREQ#	Logic input pin (from CARD)

●BLOCK DIAGRAM (BD4156MUV)

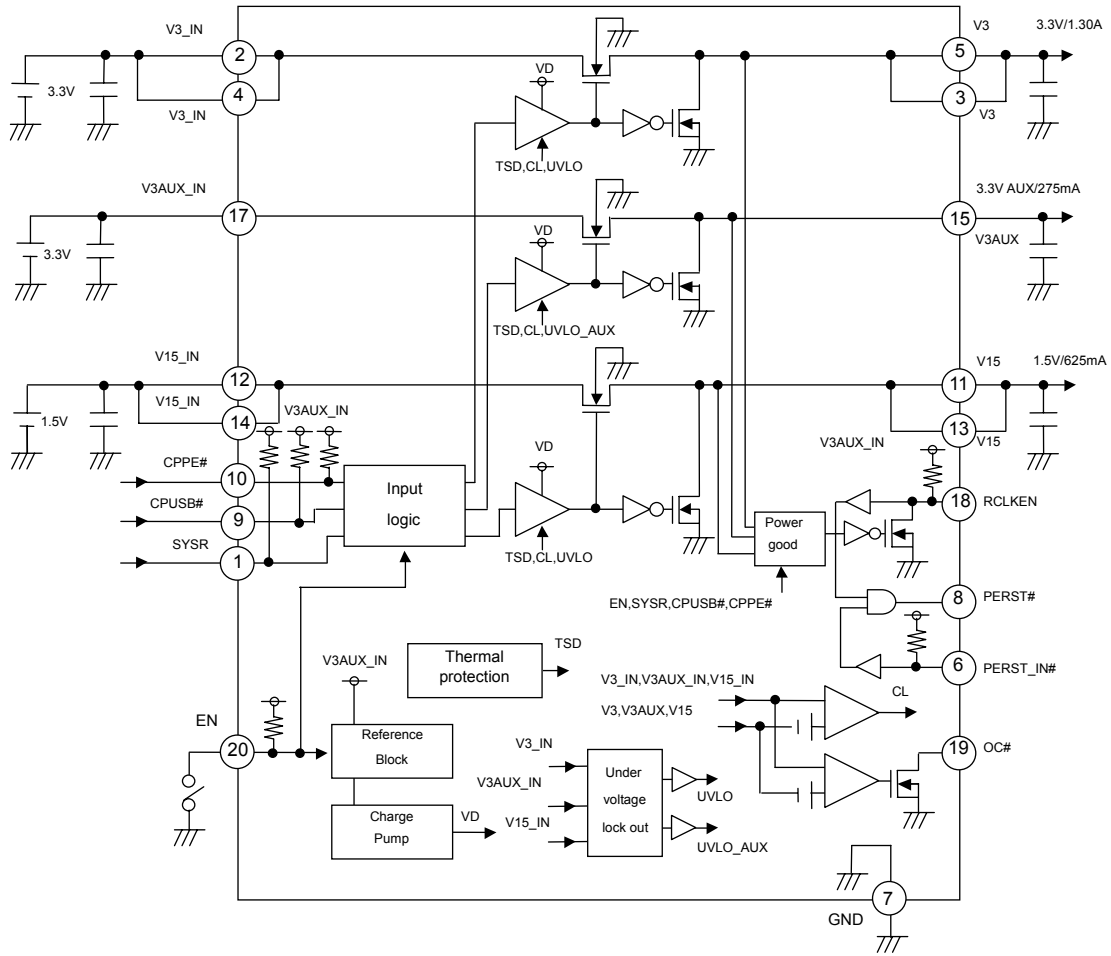

●PHYSICAL DIMENSIONS

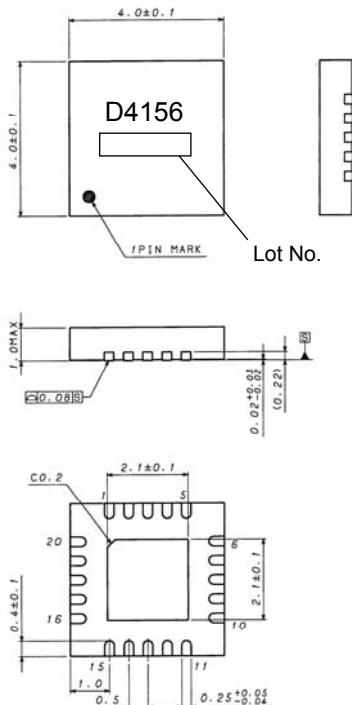

●PIN FUNCTION

PIN No	PIN NAME	PIN FUNCTION
1	SYSR	Logic input pin
2	V3_IN	V3 input pin
3	V3	V3 output pin
4	V3_IN	V3 input pin
5	V3	V3 output pin
6	PERST_IN#	PERST# control input pin (SysReset#)
7	GND	GND pin
8	PERST#	Logic output pin
9	CPUSB#	Logic input pin
10	CPPE#	Logic input pin
11	V15	V15 output pin
12	V15_IN	V15 input pin
13	V15	V15 output pin
14	V15_IN	V15 input pin
15	V3AUX	V3AUX output pin
16	TEST	Test pin
17	V3AUX_IN	V3AUX input pin 1
18	RCLKEN	Reference clock enable signal/ Power good signal (No delay)
19	OC#	over current protect signal output pin
20	EN	Enable input pin

●Description of operations

VCC (BD4153FV, BD4153EFV)

BD4153FV, BD4153EFV has an independent power input pin for an internal circuit operation in order to activate UVLO, Input logic, and charge pump, the maximum current through which is rated to 2 mA. It is recommended to connect a bypass capacitor of 0.1 μ F or so to VCC pin.

EN (BD4153FV, BD4153EFV)

With an input of 2.3 volts or higher, this terminal turns to “High” level to activate the circuit, while it turns to “Low” level to deactivate the circuit (with the standby circuit current of 35 μ A), discharges each output and lowers output voltage. If the input is lowered to 0.8 volts or less.

EN (BD4154FV/BD4156MUV)

With an input of 2.0 volts or higher, this terminal goes HIGH to activate the circuit, and goes LOW to deactivate the circuit (with the standby circuit current of 40 μ A). It discharges each output and lowers output voltage when the input falls to 0.8 volts or less.

V3_IN, V15_IN, and V3AUX_IN (BD4153FV, BD4153EFV)

These are the input terminals for each channel of a 3ch switch. V3_IN and V15_IN terminals have two pins each, which should be short-circuited on the pc board with a thick conductor. And V3AUX_IN terminal should be short-circuited to VCC terminal. Through these three terminals, a big current runs (V3_IN: 1.35A, V3AUX_IN: 0.275 A, and V15_IN: 0.625 A). In order to lower the output impedance of the power supply to be connected, it is recommended to provide ceramic capacitors (of B-characteristics or better) between these terminals and ground; 1 μ F or so between V3_IN and GND and between V15_IN and GND, and 0.1 μ F or so between V3AUX_IN and GND.

V3_IN, V15_IN, and V3AUX_IN (BD4154FV, BD4155FV, BD4156MUV)

These are the input terminals for each channel of a 3ch switch. V3_IN and V15_IN terminals have two pins each, which should be short-circuited on the pc board with a thick conductor. A large current runs through these three terminals : (V3_IN: 1.35A; V3AUX_IN: 0.275 A; and V15_IN: 0.625 A). In order to lower the output impedance of the connected power supply, it is recommended that ceramic capacitors (with B-type characteristics or better) be provided between these terminals and the ground. Specifically, the capacitors should be on the order of 1 μ F between V3_IN and GND, and between V15_IN and GND; and on the order of 0.1 μ F between V3AUX_IN and GND.

V3, V15, and V3AUX (BD4153FV, BD4153EFV, BD4154FV, BD4155FV, BD4156MUV)

These are the output terminals for each switch. V3 and V15 terminals have two pins each, which should be short-circuited on the pc board and connected to an ExpressCard connector with a thick conductor as shortest as possible. In order to stabilize the output, it is recommended to provide ceramic capacitors (of B-characteristics or better) between these terminals and ground; 10 μ F or so between V3 and GND and between V15 and GND, and 1 μ F or so between V3AUX and GND.

CPPE# (BD4153FV, BD4153EFV)

The pin used to find whether a PCI-Express signal compatible card is provided or not. Turns to “High” level with an input of 2.3 volts or higher, which means that no card is provided, while it turns to “Low” level when the input is lowered to 0.8 volts or less, which means that a card is provided. Controls turning ON/OFF of the switch according to the status of the system.

CPPE# (BD4154FV, BD4155FV, BD4156MUV)

This pin is used to find whether or not a PCI-Express signal compatible card is present. Turns to “High” level with an input of 2.0 volts or higher, which means that no card is provided, while it turns to “Low” level when the input is lowered to 0.8 volts or less, which means that a card is provided. Controls the ON/OFF, switch selecting the proper mode based on the status of the system. Pull up resistance (100k Ω ~200k Ω) is built into, so the number of components is reduced.

CPUSB# (BD4153FV, BD4153EFV)

The pin used to find whether a USB2.0 signal compatible card is provided or not. Turns to “High” level with an input of 2.3 volts or higher, which means that no card is provided, while it turns to “Low” level when the input is lowered to 0.8 volts or less, which means that a card is provided. Controls turning ON/OFF of the switch according to the system status.

CPUSB# (BD4154FV, BD4155FV, BD4156MUV)

This pin is used to find whether or not a USB2.0 signal compatible card is present. Turns to “High” level with an input of 2.0 volts or higher, which means that no card is provided, while it turns to “Low” level when the input is lowered to 0.8 volts or less, which means that a card is provided. Controls the ON/OFF switch, selecting the proper mode based on the system status.

Pull up resistance (100k Ω ~200k Ω) is built into, so the number of components is reduced.

SYSR (BD4153FV, BD4153EFV)

The pin used to detect the system status. Turns to “High” level with an input of 2.3 volts or higher, which means that the system is activated, while it turns to “Low” level when the input is lowered to 0.8 volts or less, which means that the system is on standby.

SYSR (BD4154FV, BD4156MUV)

This pin is used to detect the system status. Turns to “High” level with an input of 2.0 volts or higher, which means that the system is activated, while it turns to “Low” level when the input is lowered to 0.8 volts or less, which means that the system is on standby. (Pull up resistance (100k Ω ~200k Ω) is built into, so the number of components is reduced.)

SYSR (BD4155FV)

The pin used to detect the system status. Turns to “High” level with an input of 2.0 volts or higher, which means that the system is activated, while it turns to “Low” level when the input is lowered to 0.8 volts or less, which means that the system is on standby.

PERST_IN# (BD4153FV, BD4153EFV)

The pin used to control a reset signal to a card (PERST#) from the system side. (Also referred to as “SysReset#” by PCMCIA.) Turns to “High” level with an input of 2.3 volts or higher, and turns PERST# to “High” level AND with a “Power Good” output. Turns to “Low” level and turns PERST# to “Low” level when the input is lowered to 0.8 volts or less.

PERST_IN# (BD4154FV, BD4156MUV)

This pin is used to control the reset signal (PERST#) to a card from the system side. (Also referred to as “SysReset#” by PCMCIA.) Turns to “High” level with an input of 2.0 volts or higher, and sets PERST# to “High” AND with a “Power Good” output. Turns to “Low” level and sets PERST# to “Low” when the input falls to 0.8 volts or less.

PERST# (BD4153FV, BD4153EFV, BD4154FV, BD4156MUV)

The pin used to provide a reset signal to a PCI-Express compatible card. The status is determined by each output, PERST#_IN, CPPE# system status, and EN on/off status. Turns to “High” level and activates the PCI-Express compatible card only if each output is within the “Power Good” threshold with the card kept inserted and with PERST_IN# turned to “High” level.

PERST# (BD4155FV)

This pin is used to send a reset signal to a PCI-Express compatible card. Reset status is determined by the outputs, PLT_RST#, EC_RST#, CPPE# system status. Turns to “High” level and activates the PCI-Express compatible card only if each output is within the “Power Good” threshold, with the card inserted and PLT_RST#, EC_RST# turned to “High” level.

PERST#_DELAY (BD4153FV, BD4153EFV)

Delay during which the level at PERST# pin turns from Low to High may be set with a capacitor externally applied. The delay time is determined by the regulated current (2 μ A), the reference voltage (0.7 volts) inside the IC and the capacitance of the capacitor externally applied. The delay time is specified as “at least 1 ms” in “ExpressCard Standard”. It does not synchronize with PERST_IN#, and it synchronizes only with a “Power Good” output inside the IC. Turns to “Low” level when SW is turned OFF.

OC (BD4153FV, BD4153EFV, BD4156MUV)

Turns its output to “Low” level if an overcurrent condition is detected. This open drain output may be pulled up to 3.6 volts power supply via resistor.

OC-Delay (BD4153FV, BD4153EFV)

Delay during which the level at OC pin turns from High to Low may be set with a capacitor externally applied. The delay time is determined by the regulated current (2 μ A), the reference voltage (0.7 volts) inside the IC and the capacitance of the capacitor externally applied. May be used to control with the OC status fed back to the system. If fed back to EN terminal of this IC, it may be used to turn OFF the output that is provided when an overcurrent condition is detected.

RCLKEN (BD4154FV, BD4156MUV)

This pin is used to send an enable signal to the reference clock. Activation status is determined by the outputs, CPPE# system status, and EN on/off status. Turns to “High” level and activates the reference clock PLL only if each output is within the “Power Good” threshold, with the card kept inserted.

TEST (BD4154FV, BD4156MUV)

This pin is used to test, which should be short-circuited to the GND. When it is short-circuited to V3AUX_IN, UVLO (V3_IN, V15_IN) turns OFF.

PLT_RST#, EC_RST# (BD4155FV)

These pins are used to control the reset signal (PERST#) to a card from the system side. (Also referred to as “SysReset#” by PCMCIA.) Turns to “High” level with an input of 2.0 volts or higher, and sets PERST# to “High” AND with a “Power Good” output. Turns to “Low” level and sets PERST# to “Low” when the input falls to 0.8 volts or less.

EC_CLKEN#, EC_CLKREQ# (BD4155FV)

These pins are used to control the enable signal (PLL_CLKREQ#) to the reference clock. Turns to “High” level and set PLL_CLKREQ# to “High” when the input rise to 2.0 volts or higher. Turns to “Low” level with an input of 0.8 volts or less, and sets PLL_CLKREQ# to “Low” or with a inverting “Power Good” output.

PLL_CLKREQ# (BD4155FV)

This pin is used to send an enable signal to the reference clock. Activation status is determined by the outputs, EC_CLKEN#, EC_CLKREQ#, CPPE# system status. Turns to “Low” level and activates the reference clock PLL only if each output is within the “Power Good” threshold, with the card kept inserted, and EC_CLKEN#, EC_CLKREQ# turned to “Low” level.

●TIMING CHART

Power ON/OFF Status of ExpressCard™

System Status		ExpressCARD™ Module Status	Power Switch Status	
Primary	Auxiliary		Primary	Auxiliary
OFF	OFF	Don't Care	OFF	OFF
ON	ON	De-asserted	OFF	OFF
		Asserted	ON	ON
ON	ON	De-asserted	OFF	OFF
		Asserted Before This	OFF	ON
		Asserted After This	OFF	OFF

ExpressCard™ States Transition Diagram

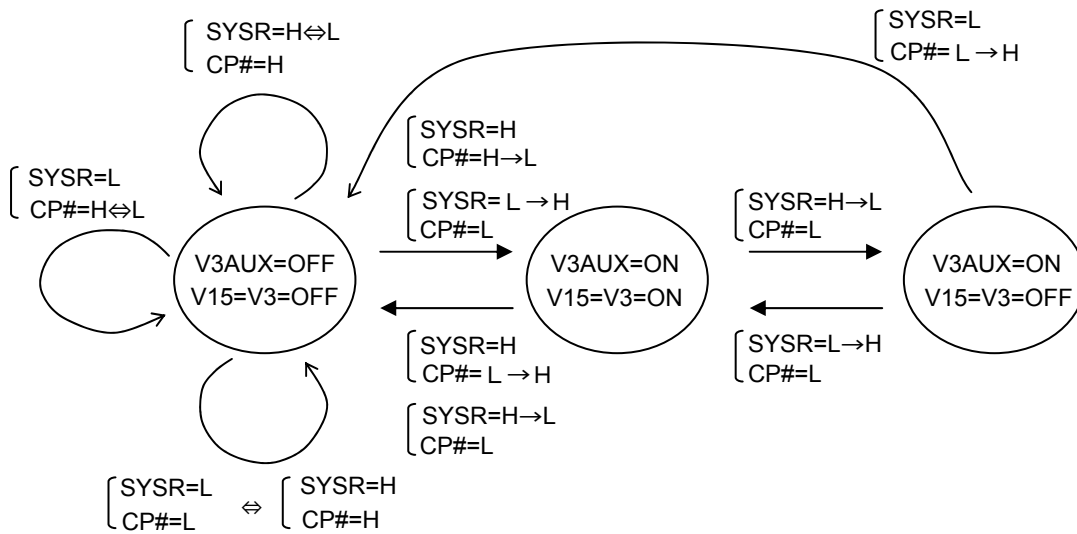

System Status		Card Status	
Stand-by Status	:SYSR=L	Card Asserted Status	:CP#=L
ON Status	:SYSR=H	Card De-asserted Status	:CP#=H
From ON to Stand-by Status	:SYSR=H→L	From De-asserted to Asserted Status	:CP#=H→L
From Stand-by to ON Status	:SYSR=L→H	From Asserted to De-asserted Status	:CP#=L→H

●OUTPUT CONDITION LIST (Output) (BD4154FV, BD4156MUV)

State	Power Supply			Logic input				Output	
	V3AUX_IN	V3_IN	V15_IN	EN	SYSR	CPPE#	CPUSB#	V3/V15	V3AUX
OFF	0	×	×	×	×	×	×	OFF	OFF
Shut down	1	×	×	0	×	×	×	OFF	OFF
ON ↓ Stand-by	1	×	×	1	1→0	1	1	OFF	OFF
						×	0	OFF	ON
						0	×	OFF	ON
Stand-by	1	×	×	1	0	×	×	OFF	OFF
ON	1	1	1	1	1	1	1	OFF	OFF
						×	0	ON	ON
						0	×	ON	ON

State	Logic input		Logic output	
	PERST_IN#	RCLKEN(Input)	PERST#	RCLKEN
OFF	×	×	0	0
Shut down	×	×	0	0
Stand-by	×	×	0	0
ON(No Card)	×	×	0	0
ON(CPUSB#=0)	0	Hiz	0	0
	0	0	0	0
	1	Hiz	0	0
	1	0	0	0
ON(CPPE#=0)	0	Hiz	0	1
	0	0	0	0
	1	Hiz	1	1
	1	0	0	0

Condition				Output	
CPxx#	UVLO (V3/V15)	UVLO (V3AUX)	Thermal	V3/V15	V3AUX
H	—	—	—	L	L
L	ON	OFF	OFF	Hi-Z	H
	—	ON		L	L
	OFF	OFF		H	H
	—	—	ON	Hi-Z	Hi-Z

OUTPUT CONDITION LIST (Protect Circuit)

State	Input						Output	
	V3AUX_IN	V3_IN	V15_IN	SYSR	CPPE#	CPUSB#	V3/V15	V3AUX
OFF	0	0	0	0	X	X	OFF	OFF
ON ↓ Stand-by	1	X	X	1→0	1	1	OFF	OFF
					X	0	OFF	ON
Stand-by	1	X	X	0	0	X	OFF	ON
					1	1	OFF	OFF
					X	0	OFF	OFF
ON	1	1	1	1	0	X	OFF	OFF
					1	1	OFF	OFF
					X	0	ON	ON
					0	X	ON	ON

OUTPUT CONDITION LIST (Logic)

State	Input									Output
	V3AUX_IN	V3_IN	V15_IN	SYSR	CPPE#	CPUSB#	POWER GOOD	PLT_RST#	EC_RST#	PERST#
OFF	0	0	0	0	X	X	X	X	X	L
Stand-by	1	X	X	0	X	X	X	X	X	L
ON	1	1	1	1	1	1	X	X	X	L
					0	X	NG	X	X	L
					0	X	OK	0	0	L
							OK	1	1	L
									0	L
					1	0	X	X	X	X

OUTPUT CONDITION LIST (PERST#)

State	Input								Output	
	V3AUX_IN	V3_IN	V15_IN	SYSR	CPPE#	CPUSB#	POWER GOOD	EC_CLKREQ#	EC_CLKEN#	PLL_CLKREQ#
OFF	0	0	0	0	X	X	X	X	X	Hi-Z
Stand-by	1	X	X	0	X	X	X	X	X	L
ON	1	1	1	1	1	1	X	X	X	H
					0	X	NG	X	X	H
					0	X	OK	0	0	L
							OK	1	1	H
									0	H
					1	0	X	X	X	X

OUTPUT CONDITION LIST (PLL_CLKREQ#)

■ BD4153FV, BD4153EFV Evaluation Board Circuit

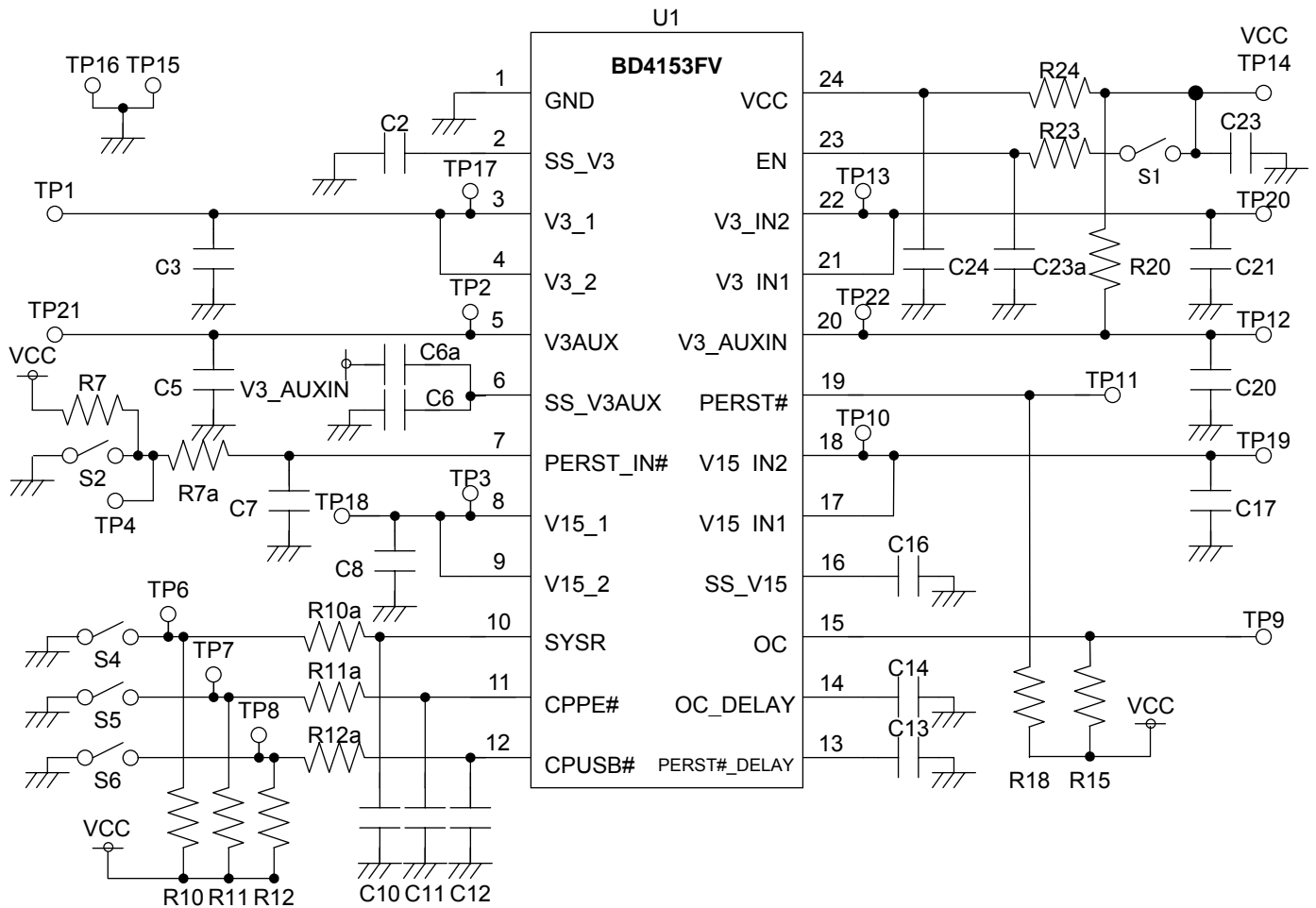

■ BD4153FV, BD4153EFV Evaluation Board Application Components

Part No	Value	Company	Part Name
U1	-	ROHM	BD4153FV
R7	10k Ω	ROHM	MCR03series
R10	10k Ω	ROHM	MCR03series
R10a	0 Ω	ROHM	MCR03series
R11	120k Ω	ROHM	MCR03series
R11a	0 Ω	ROHM	MCR03series
R12	120k Ω	ROHM	MCR03series
R12a	0 Ω	ROHM	MCR03series
R15	10k Ω	ROHM	MCR03series
R18	-		-
R20	0 Ω	ROHM	MCR03series
R23	0 Ω	ROHM	MCR03series
R24	10 Ω	ROHM	MCR03series
C2	2200pF	MURATA	GRM1881X1H222JA01B
C3	10 μ F	MURATA	GRM31CB10J106KC01B
C5	1 μ F	MURATA	GRM188B10J105KA01B
C6	0.01 μ F	MURATA	GRM1881X1H103JA01B

Part No	Value	Company	Part Name
C6a	-	-	-
C7	-	-	-
C8	10 μ F	MURATA	GRM31CB10J106KC01B
C10	-	-	-
C11	-	-	-
C12	-	-	-
C13	0.033 μ F	MURATA	GRM155B11A333
C14	0.22 μ F	MURATA	GRM188B11A224KA61B
C16	2200pF	MURATA	GRM1881X1H222JA01B
C17	1 μ F	MURATA	GRM188B10J105KA01B
C20	0.1 μ F	MURATA	GRM155B11A104
C21	1 μ F	MURATA	GRM188B10J105KA01B
C23	0.1 μ F	MURATA	GRM155B11A104
C23a	-	-	-
C24	0.1 μ F	MURATA	GRM155B11A104

■ BD4154FV, BD4156MUV Evaluation Board

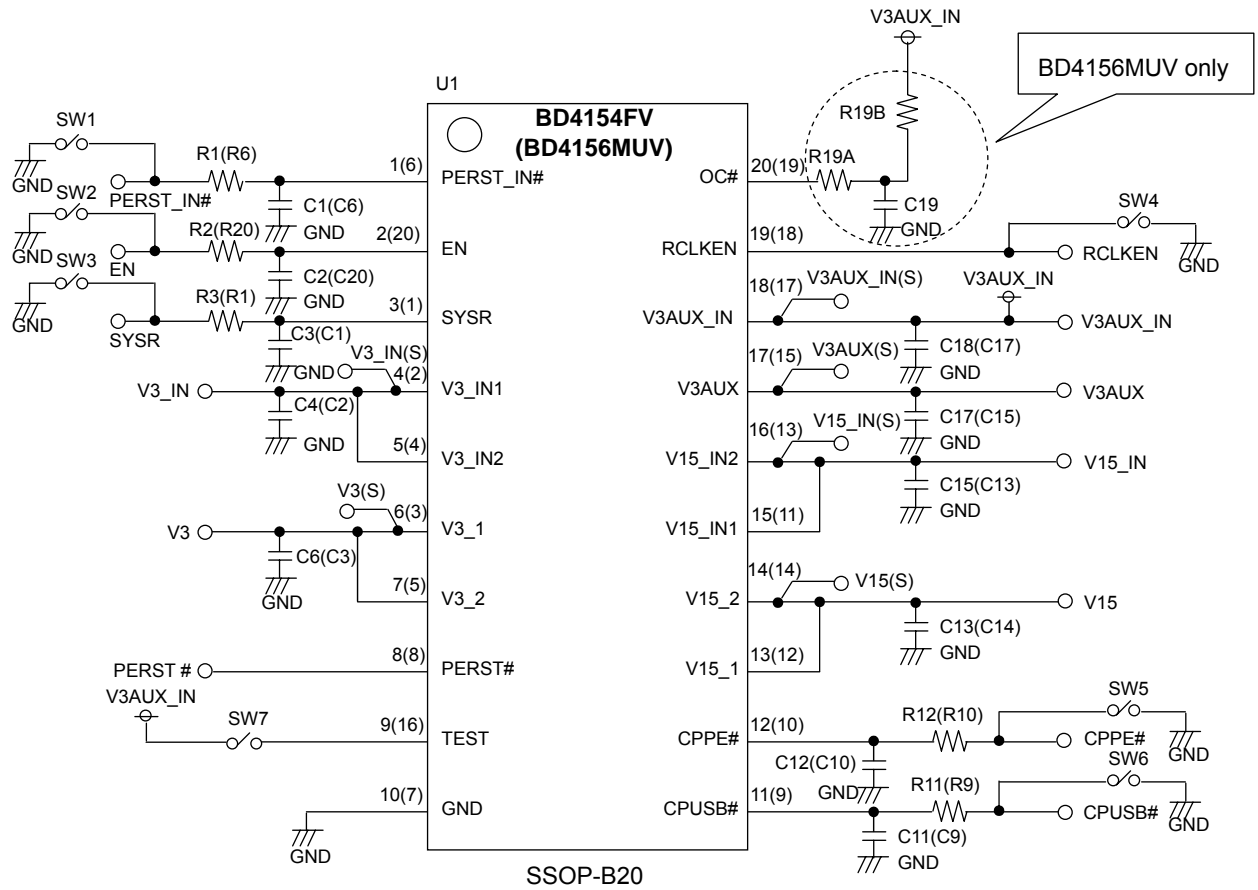

■ BD4154FV, BD4156MUV Evaluation Board Application Components

Part No	Value	Company	Part Name
R1(R6)	0Ω	ROHM	MCR03series
R2(R20)	0Ω	ROHM	MCR03series
R3(R1)	0Ω	ROHM	MCR03series
R11(R9)	0Ω	ROHM	MCR03series
R12(R10)	0Ω	ROHM	MCR03series
R19A	0Ω	ROHM	MCR03series
R19B	20kΩ	ROHM	MCR03series
C1(C6)	-	-	-
C2(C20)	-	-	-
C3(C1)	-	-	-
C4(C2)	1μF	MURATA	GRM188B10J105KA01B
C6(C3)	10μF	MURATA	GRM31CB10J106KC01B
C11(C9)	-	-	-
C12(C10)	-	-	-
C13(C14)	10μF	MURATA	GRM31CB10J106KC01B
C15(C13)	1μF	MURATA	GRM188B10J105KA01B
C17(C15)	1μF	MURATA	GRM188B10J105KA01B
C18(C17)	0.1μF	MURATA	GRM155B11A104
C19	-	-	-

※ BD4156MUV

※ BD4156MUV

※ BD4156MUV

●NOTE FOR USE

1.Absolute maximum ratings

For the present product, thoroughgoing quality control is carried out, but in the event that applied voltage, working temperature range, and other absolute maximum rating are exceeded, the present product may be destroyed. Because it is unable to identify the short mode, open mode, etc., if any special mode is assumed, which exceeds the absolute maximum rating, physical safety measures are requested to be taken, such as fuses, etc.

2.GND potential

Bring the GND terminal potential to the minimum potential in any operating condition.

3.Thermal design

Consider allowable loss (Pd) under actual working condition and carry out thermal design with sufficient margin provided.

4.Terminal-to-terminal short-circuit and erroneous mounting

When the present IC is mounted to a printed circuit board, take utmost care to direction of IC and displacement. In the event that the IC is mounted erroneously, IC may be destroyed. In the event of short-circuit caused by foreign matter that enters in a clearance between outputs or output and power-GND, the IC may be destroyed.

5.Operation in strong electromagnetic field

The use of the present IC in the strong electromagnetic field may result in maloperation, to which care must be taken.

6.Built-in thermal shutdown protection circuit

The present IC incorporates a thermal shutdown protection circuit (TSD circuit). The working temperature is 175°C (standard value) and has a -15°C (standard value) hysteresis width. When the IC chip temperature rises and the TSD circuit operates, the output terminal is brought to the OFF state. The built-in thermal shutdown protection circuit (TSD circuit) is first and foremost intended for interrupt IC from thermal runaway, and is not intended to protect and warrant the IC. Consequently, never attempt to continuously use the IC after this circuit is activated or to use the circuit with the activation of the circuit premised.

7.Capacitor across output and GND

In the event a large capacitor is connected across output and GND, when Vcc and VIN are short-circuited with 0V or GND for some kind of reasons, current charged in the capacitor flows into the output and may destroy the IC. Use a capacitor smaller than 1000 μF between output and GND.

8.Inspection by set substrate

In the event a capacitor is connected to a pin with low impedance at the time of inspection with a set substrate, there is a fear of applying stress to the IC. Therefore, be sure to discharge electricity for every process. As electrostatic measures, provide grounding in the assembly process, and take utmost care in transportation and storage. Furthermore, when the set substrate is connected to a jig in the inspection process, be sure to turn OFF power supply to connect the jig and be sure to turn OFF power supply to remove the jig.

9.IC terminal input

The present IC is a monolithic IC and has a P substrate and P⁺ isolation between elements.

With this P layer and N layer of each element, PN junction is formed, and when the potential relation is

- GND>terminal A>terminal B, PN junction works as a diode, and
- terminal B>GND terminal A, PN junction operates as a parasitic transistor.

The parasitic element is inevitably formed because of the IC construction. The operation of the parasitic element gives rise to mutual interference between circuits and results in malfunction, and eventually, breakdown. Consequently, take utmost care not to use the IC to operate the parasitic element such as applying voltage lower than GND (P substrate) to the input terminal.

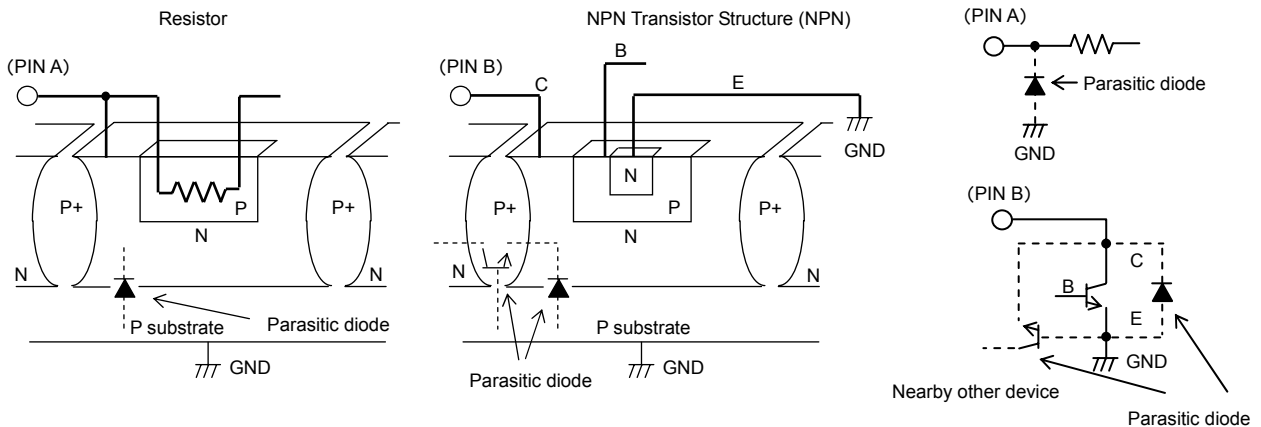

10. GND wiring pattern

If there are a small signal GND and a high current GND, it is recommended to separate the patterns for the high current GND and the small signal GND and provide a proper grounding to the reference point of the set not to affect the voltage at the small signal GND with the change in voltage due to resistance component of pattern wiring and high current. Also for GND wiring pattern of component externally connected, pay special attention not to cause undesirable change to it.

11. Electrical characteristics

The electrical characteristics in the Specifications may vary depending on ambient temperature, power supply voltage, circuit(s) externally applied, and/or other conditions. It is therefore requested to carefully check them including transient characteristics.

12. Capacitors to be applied to the input terminals

The capacitors to be applied to the input terminals (VCC, V3_IN, V3AUX_IN and V15_IN) are used to lower the output impedance of the power supply to be connected. An increase in the output impedance of the power supply may result in destabilization of input voltages (VCC, V3_IN, V3AUX_IN and V15_IN). It is recommended to use a low ESR capacitor with less temperature coefficient (change in capacitance vs. change in temperature), 0.1 μF more or less for VCC and V3AUX_IN while 1 μF more or less for V3_IN and V15_IN, but it must be thoroughly checked at the temperature and with the load of the range expected to use because it significantly depends on the characteristics of the input power supply to be used and the conductor pattern of the pc board.

13. Capacitors to be applied to the output terminals

To the output terminals (V3, V3_AUX, and V15), the output capacitors should be connected between the respective output terminal and GND. It is recommended to use a low ESR capacitor with less temperature coefficient, 1 μF more or less for V3 and V15 terminals while 1 μF more or less for V3_AUX, but it must be thoroughly checked at the temperature and with the load of the range expected to use because it significantly depends on the temperature and the load conditions.

14. Not of a radiation-resistant design.

15. Allowable loss Pd

With respect to the allowable loss, the thermal derating characteristics are shown in the Exhibit, which we hope would be used as a good-rule-of-thumb. Should the IC be used in such a manner to exceed the allowable loss, reduction of current capacity due to chip temperature rise, and other degraded properties inherent to the IC would result. You are strongly urged to use the IC within the allowable loss.

16. In the event that load containing a large inductance component is connected to the output terminal, and generation of back-EMF at the start-up and when output is turned OFF is assumed, it is requested to insert a protection diode.

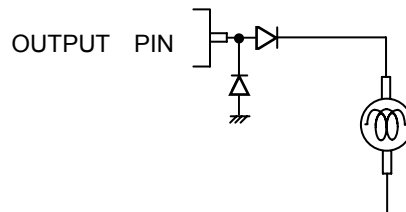

17. Operating ranges

If it is within the operating ranges, certain circuit functions and operations are warranted in the working ambient temperature range. With respect to characteristic values, it is unable to warrant standard values of electric characteristics but there are no sudden variations in characteristic values within these ranges.

18. We are certain that examples of applied circuit diagrams are recommendable, but you are requested to thoroughly confirm the characteristics before using the IC. In addition, when the IC is used with the external circuit changed, decide the IC with sufficient margin provided while consideration is being given not only to static characteristics but also variations of external parts and our IC including transient

19. Wiring to the input terminals (V3 IN, V3AUX IN, and V15 IN) and output terminals (V3, V3AUX and V15) of built-in FET should be carried out with special care. Unnecessarily long and/or thin conductors used in wiring may result in degradation of characteristics including decrease in output voltage.

20. Heat sink

Heat sink is connected to SUB, which should be short-circuited to GND. Solder the heat sink to a pc board properly, which offers lower thermal resistance.

●POWER DISSIPATION

◎BD4153FV

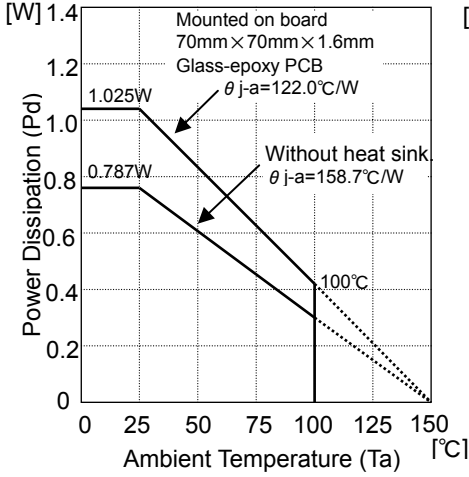

◎BD4153EFV

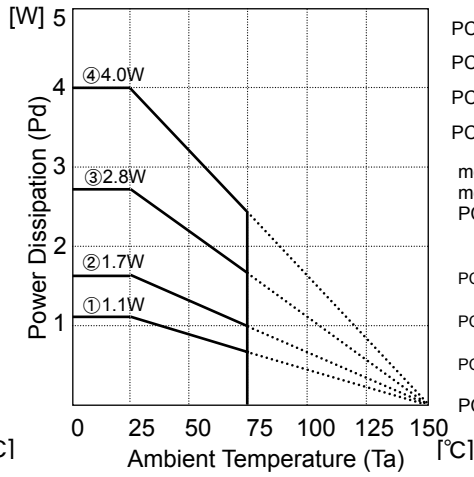

PCB① : $\theta_{ja}=113.6^{\circ}\text{C/W}$

PCB② : $\theta_{ja}=43.5^{\circ}\text{C/W}$

PCB③ : $\theta_{ja}=44.6^{\circ}\text{C/W}$

PCB④ : $\theta_{ja}=31.3^{\circ}\text{C/W}$

measure : TH-156 (Kuwano-Denki)
measure condition : Rohm Standard Board
PCB size : 70mm x 70mm x 1.6mm
(PCB with Thermal Via)

PCB① : Single-layer substrate
(substrate surface copper foil area:0mm x 0mm)

PCB② : Double-layer substrate
(substrate surface copper foil area:15mm x 15mm)

PCB③ : Double-layer substrate
(substrate surface copper foil area:70mm x 70mm)

PCB④ : Fourth-layer substrate
(substrate surface copper foil area:70mm x 70mm)

●Ordering part number

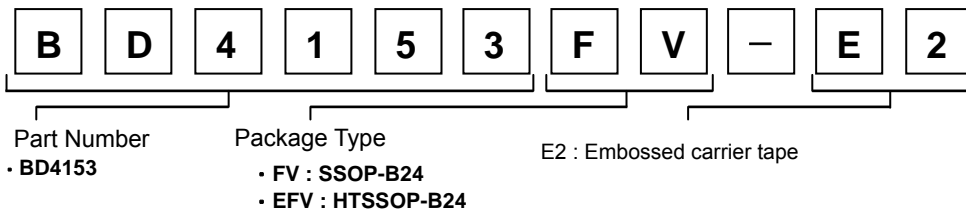

SSOP-B24

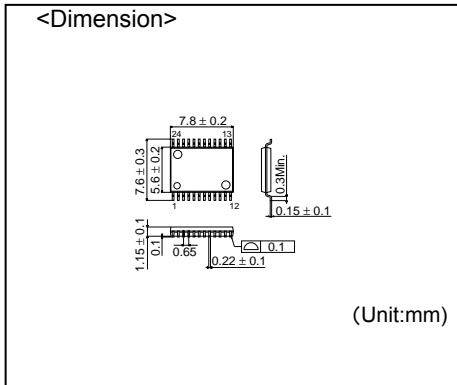

<Tape and Reel information>

Tape	Embossed carrier tape
Quantity	2000pcs
Direction of feed	E2 (The direction is the 1pin of product is at the upper left when you hold reel on the left hand and you pull out the tape on the right hand)

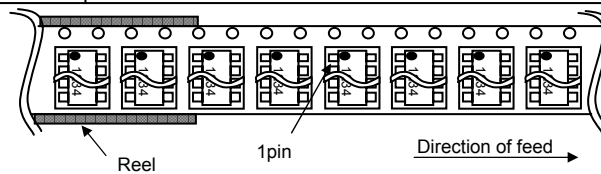

HTSSOP-B24

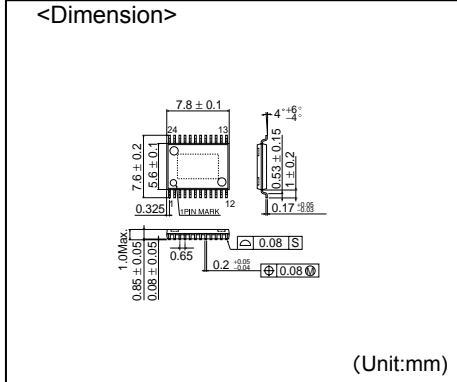

<Tape and Reel information>

Tape	Embossed carrier tape
Quantity	2000pcs
Direction of feed	E2 (The direction is the 1pin of product is at the upper left when you hold reel on the left hand and you pull out the tape on the right hand)

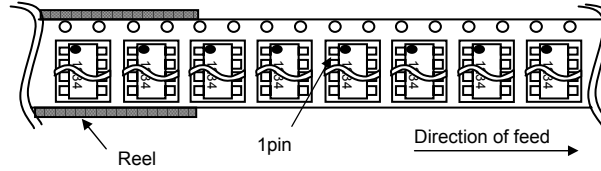

※When you order , please order in times the amount of package quantity.

● POWER DISSIPATION
 ◎ BD4154FV, BD4155FV

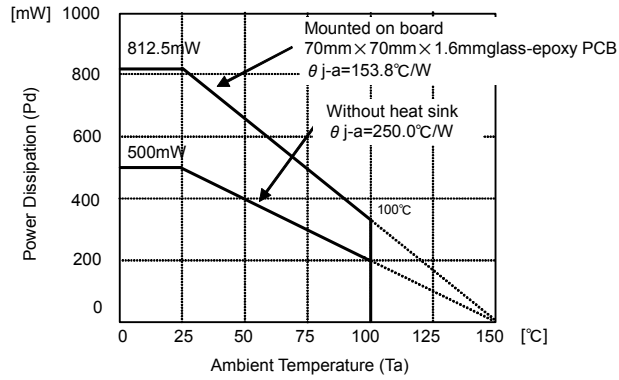

● Ordering part number

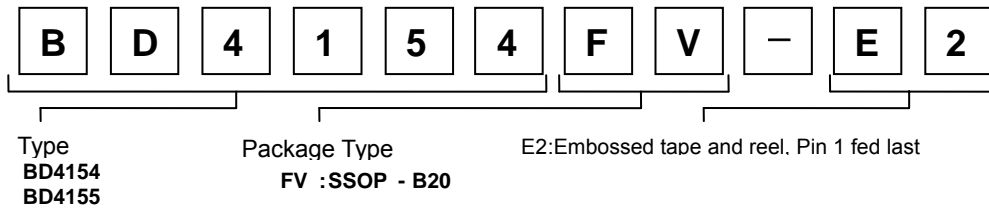

SSOP-B20

<Dimensions>

(Unit:mm)

<Tape and Reel information>

Tape	Embossed carrier tape
Quantity/Reel	2500pcs
Direction of feed	E2 (With reel in left hand, unreeling with the right, the index pin [1-pin] is at top left)

※Please order by the number of reels desired.bb

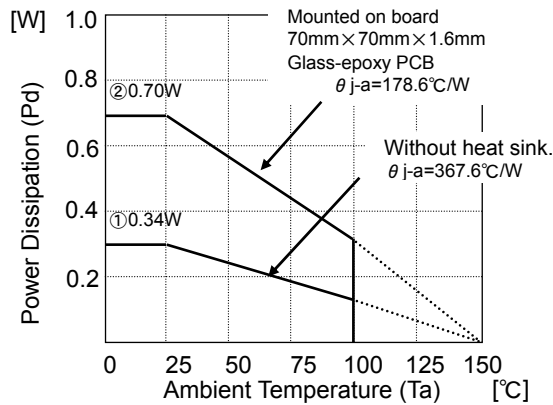

● Ordering part number

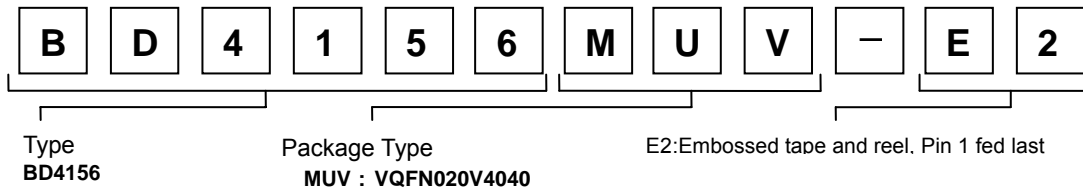

VQFN020V4040

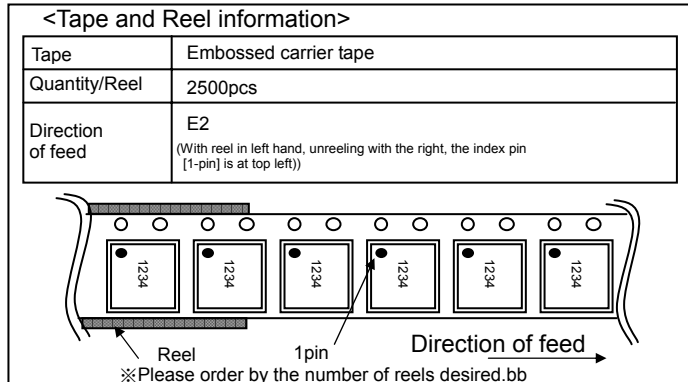
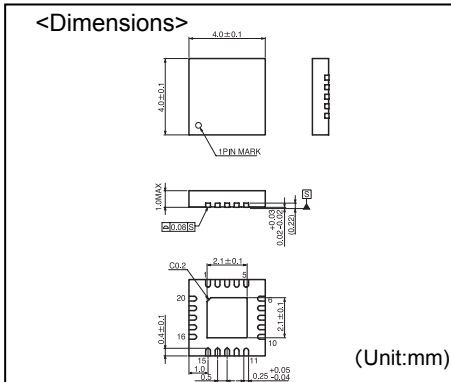

- The contents described herein are correct as of November, 2006
- The contents described herein are subject to change without notice. For updates of the latest information, please contact and confirm with ROHM CO.,LTD.
- Any part of this application note must not be duplicated or copied without our permission.
- Application circuit diagrams and circuit constants contained herein are shown as examples of standard use and operation. Please pay careful attention to the peripheral conditions when designing circuits and deciding upon circuit constants in the set.
- Any data, including, but not limited to application circuit diagrams and information, described herein are intended only as illustrations of such devices and not as the specifications for such devices, ROHM CO.,LTD. disclaims any warranty that any use of such devices shall be free from infringement of any third party's intellectual property rights or other proprietary rights, and further, assumes no liability of whatsoever nature in the event of any such infringement, or arising from or connected with or related to the use of such devices.
- Upon the sale of any such devices, other than for buyer's right to use such devices itself, resell or otherwise dispose of the same, implied right or license to practice or commercially exploit any intellectual property rights or other proprietary rights owned or controlled by ROHM CO., LTD. is granted to any such buyer.
- The products described herein utilize silicon as the main material.
- The products described herein are not designed to be X ray proof.

The products listed in this catalog are designed to be used with ordinary electronic equipment or devices (such as audio visual equipment, office-automation equipment, communications devices, electrical appliances and electronic toys). Should you intend to use these products with equipment or devices which require an extremely high level of reliability and the malfunction of which would directly endanger human life (such as medical instruments, transportation equipment, aerospace machinery, nuclear-reactor controllers, fuel controllers and other safety devices), please be sure to consult with our sales representative in advance.

Contact us for further information about the products.

- | | |
|---|---|
| Seoul TEL: +82-2-8182-700 FAX: +82-2-8182-715 | Bangkok TEL: +66-2-254-4890 FAX: +66-2-256-6334 |
| Masan TEL: +82-55-240-6234 FAX: +82-55-240-6236 | Kuala Lumpur TEL: +60-3-7958-8355 FAX: +60-3-7958-8377 |
| Dalian TEL: +86-411-8230-8549 FAX: +86-411-8230-8537 | Penang TEL: +60-4-6585084 FAX: +60-4-6585167 |
| Beijing TEL: +86-10-8525-2483 FAX: +86-10-8525-2489 | Dusseldorf TEL: +49-2145-9210 FAX: +49-2154-921400 |
| Tianjin TEL: +86-22-23029181 FAX: +86-22-23029183 | Munich TEL: +49-8161-48310 FAX: +49-8161-483120 |
| Shanghai TEL: +86-21-6279-2727 FAX: +86-21-6247-2066 | Stuttgart TEL: +49-711-72723710 FAX: +49-711-72723720 |
| Hangzhou TEL: +86-571-87658072 FAX: +86-571-87658071 | France TEL: +33-1-5697-3060 FAX: +33-1-5697-3080 |
| Nanjing TEL: +86-25-8689-0015 FAX: +86-25-8689-0393 | United Kingdom TEL: +44-1-908-306700 FAX: +44-1-908-235788 |
| Ningbo TEL: +86-574-87654201 FAX: +86-574-87654208 | Denmark TEL: +45-3694-4739 FAX: +45-3694-4789 |
| Qingdao TEL: +86-532-5779-312 FAX: +86-532-5779-653 | Barcelona TEL: +34-9375-24320 FAX: +34-9375-24410 |
| Suzhou TEL: +86-512-6807-1300 FAX: +86-512-6807-2300 | Malaga TEL: +34-9520-20263 FAX: +34-9520-20023 |
| Tianjin TEL: +86-22-23029181 FAX: +86-22-23029183 | Hungary TEL: +36-1-4719338 FAX: +36-1-4719339 |
| Wuxi TEL: +86-510-82702693 FAX: +86-510-82702992 | Poland TEL: +48-22-5757213 FAX: +48-22-5757001 |
| Hong Kong TEL: +852-2-740-6262 FAX: +852-2-375-8971 | Russia TEL: +7-95-980-6755 FAX: +7-95-937-8290 |
| Dongguan TEL: +86-769-393-3320 FAX: +86-769-398-4140 | San Diego TEL: +1-858-625-3630 FAX: +1-858-625-3670 |
| Fuzhou TEL: +86-591-8801-8698 FAX: +86-591-8801-8690 | Atlanta TEL: +1-770-754-5972 FAX: +1-770-754-0691 |
| Guangzhou TEL: +86-20-8364-9796 FAX: +86-20-8364-9707 | Boston TEL: +1-978-371-0382 FAX: +1-928-438-7164 |
| Shenzhen TEL: +86-755-8307-3001 FAX: +86-755-8307-3003 | Chicago TEL: +1-847-368-1006 FAX: +1-847-368-1008 |
| Xiamen TEL: +86-592-239-8382 FAX: +86-592-239-8380 | Dallas TEL: +1-972-312-8818 FAX: +1-972-312-0330 |
| Zhuhai TEL: +86-756-3232-460 FAX: +86-756-3232-460 | Denver TEL: +1-303-708-0908 FAX: +1-303-708-0858 |
| Taipei TEL: +886-2-2500-6956 FAX: +886-2-2503-2869 | Nashville TEL: +1-615-620-6700 FAX: +1-615-620-6702 |
| Kaohsiung TEL: +886-7-237-0881 FAX: +886-7-238-7332 | Guadalajara TEL: +52-33-3123-2001 FAX: +52-33-3123-2002 |
| Singapore TEL: +65-6332-2322 FAX: +65-6332-5662 | |
| Manila TEL: +63-2-807-6872 FAX: +63-2-809-1422 | |

Excellence in Electronics



ROHM CO., LTD.

21, Saiin Mizosaki-cho, Ukyo-ku, Kyoto
 615-8585, Japan
 TEL: +81-75-311-2121 FAX: +81-75-315-0172
 URL: <http://www.rohm.com>

Published by
 LSI Business Promotion Dept.

Notes

- No technical content pages of this document may be reproduced in any form or transmitted by any means without prior permission of ROHM CO.,LTD.
- The contents described herein are subject to change without notice. The specifications for the product described in this document are for reference only. Upon actual use, therefore, please request that specifications to be separately delivered.
- Application circuit diagrams and circuit constants contained herein are shown as examples of standard use and operation. Please pay careful attention to the peripheral conditions when designing circuits and deciding upon circuit constants in the set.
- Any data, including, but not limited to application circuit diagrams information, described herein are intended only as illustrations of such devices and not as the specifications for such devices. ROHM CO.,LTD. disclaims any warranty that any use of such devices shall be free from infringement of any third party's intellectual property rights or other proprietary rights, and further, assumes no liability of whatsoever nature in the event of any such infringement, or arising from or connected with or related to the use of such devices.
- Upon the sale of any such devices, other than for buyer's right to use such devices itself, resell or otherwise dispose of the same, no express or implied right or license to practice or commercially exploit any intellectual property rights or other proprietary rights owned or controlled by
- ROHM CO., LTD. is granted to any such buyer.
- Products listed in this document are no antiradiation design.

The products listed in this document are designed to be used with ordinary electronic equipment or devices (such as audio visual equipment, office-automation equipment, communications devices, electrical appliances and electronic toys).

Should you intend to use these products with equipment or devices which require an extremely high level of reliability and the malfunction of which would directly endanger human life (such as medical instruments, transportation equipment, aerospace machinery, nuclear-reactor controllers, fuel controllers and other safety devices), please be sure to consult with our sales representative in advance.

It is our top priority to supply products with the utmost quality and reliability. However, there is always a chance of failure due to unexpected factors. Therefore, please take into account the derating characteristics and allow for sufficient safety features, such as extra margin, anti-flammability, and fail-safe measures when designing in order to prevent possible accidents that may result in bodily harm or fire caused by component failure. ROHM cannot be held responsible for any damages arising from the use of the products under conditions out of the range of the specifications or due to non-compliance with the NOTES specified in this catalog.

Thank you for your accessing to ROHM product informations.

More detail product informations and catalogs are available, please contact your nearest sales office.

ROHM Customer Support System

THE AMERICAS / EUROPE / ASIA / JAPAN

www.rohm.com

Contact us : webmaster@rohm.co.jp