

**CABLE ASSEMBLY WORK
INSTRUCTION GTC-E**

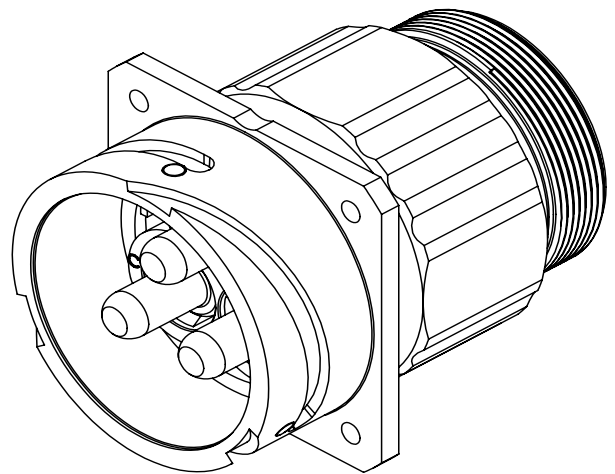
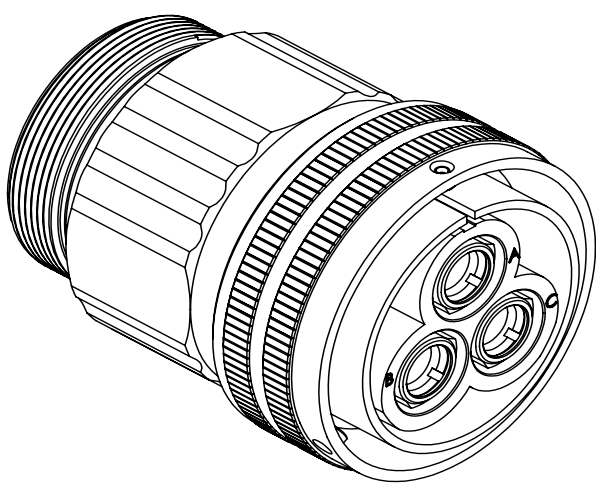

Writer	Bruce Lee
Product Series	EGT Series
Date	11/9/2021

Contents

1.	Product Component.....	-1-
	1) EGT06R36-4S.....	-1-
	2) EGT030R6-4P.....	-2-
2.	Product Assembly.....	-3-
	1) Preparation before assembly.....	-3-
	2) Stripping cable and Crimp Contacts.....	-3-
	3) Assembly Connector.....	-4-
	Appendix.....	-5-
	Appendix 1: Recommend Crimp Tool.....	-5-
	Appendix 2: Recommend Installation Torque.....	-5-
	Appendix 3: Extraction Tool.....	-5-

1. Product Components

3.	Revision History.....	-5-
1)	EGT06R36-4S	

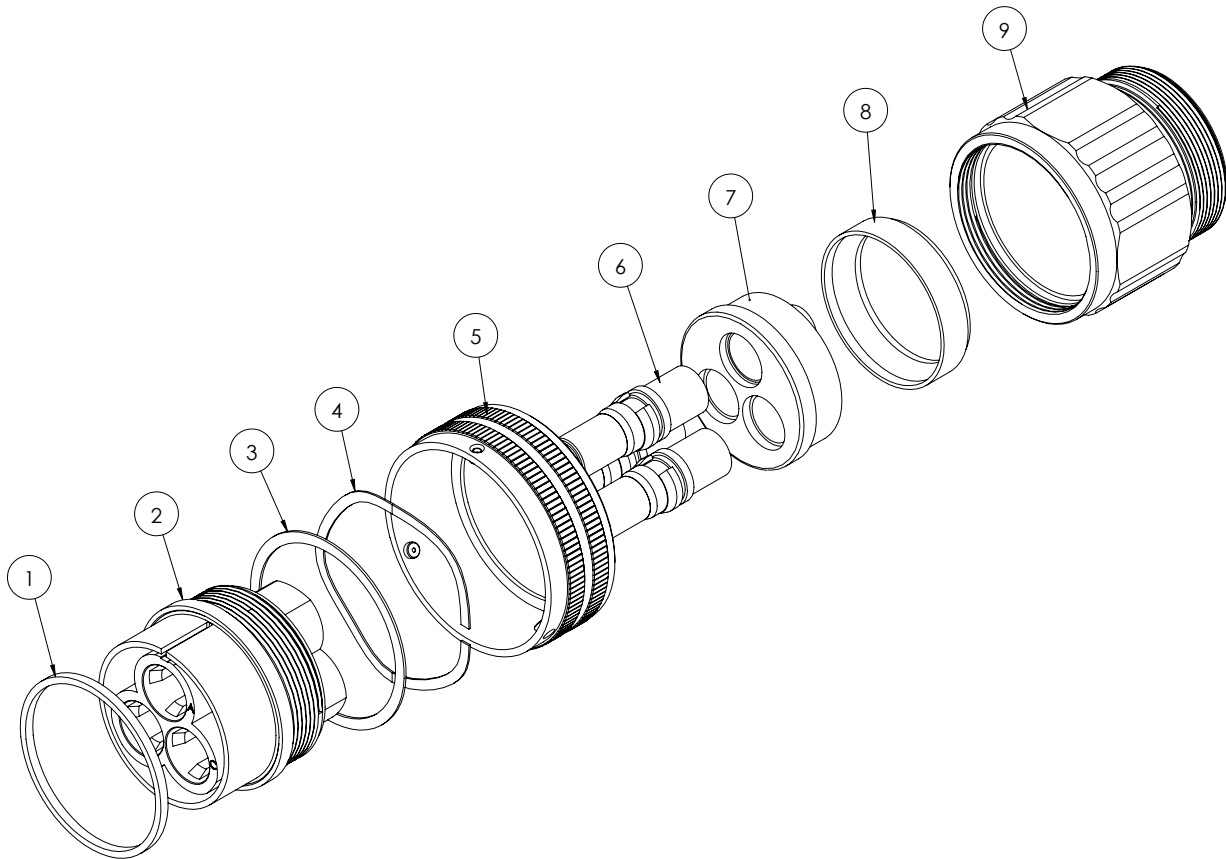

Item	Description
1	Washer, Sealing
2	Plug Assembly
3	Washer, Flat
4	Washer, Waved
5	Coupling Nut
6	Socket Contact
7	Grommet
8	Sleeve
9	Adapter

2) EGT030R36-4P

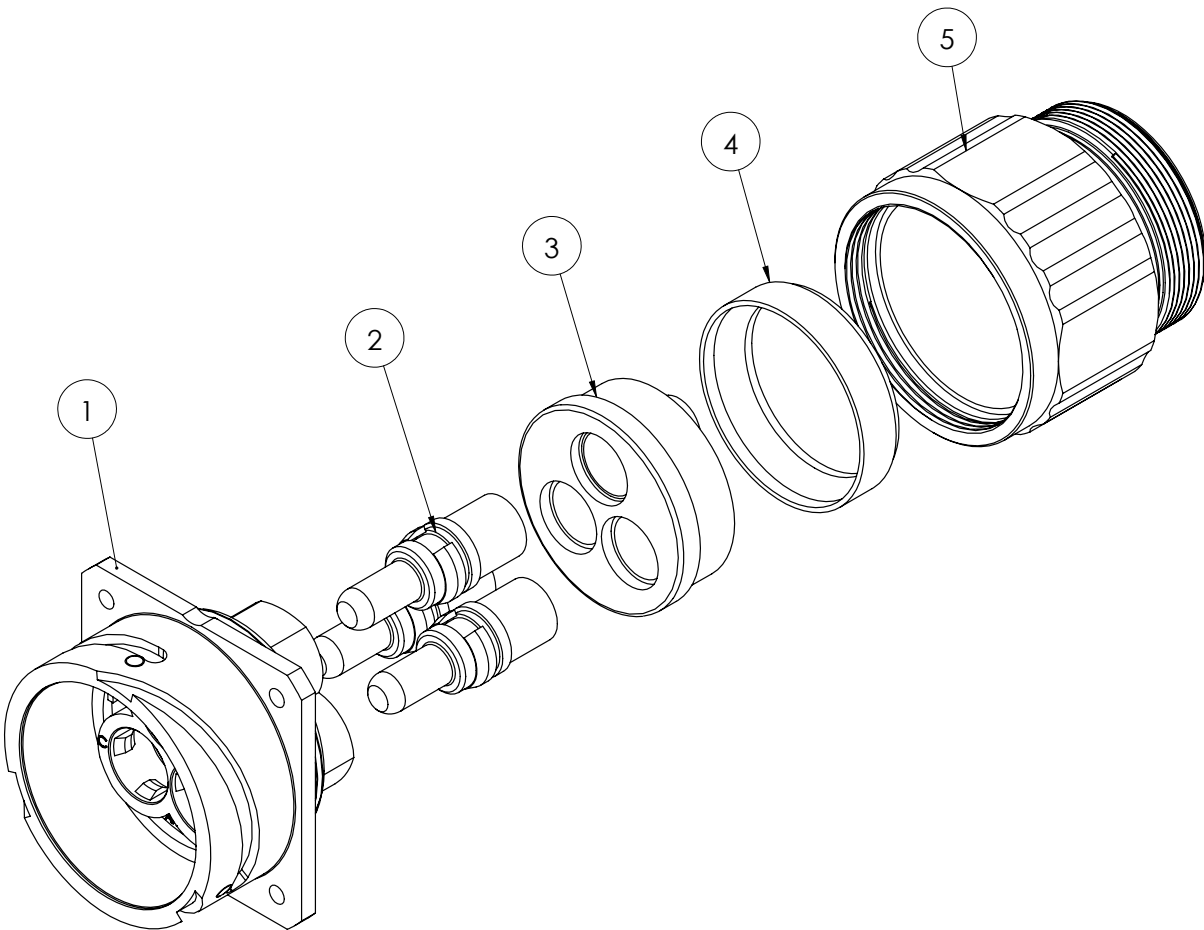

Item	Description
1	Receptacle Assembly
2	Pin Contact
3	Grommet
4	Sleeve
5	Adapter

2. Product Assembly

1) Preparation before assembly

First pass the cable through the adapter, sleeve and grommet

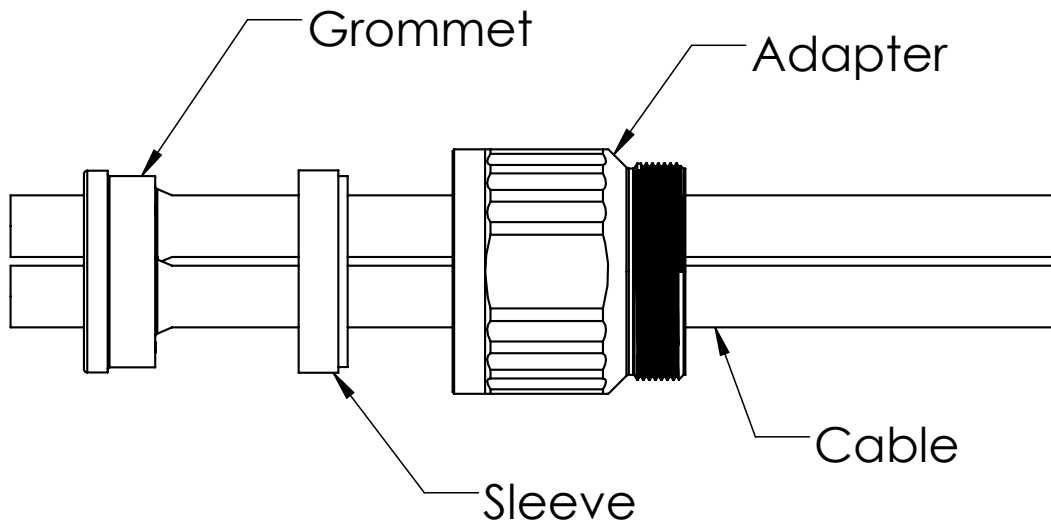

2) Strip Cable and Crimp the Contacts

Cut and strip the wire as shown in Figure 2 to expose the cable conductor. When cutting the cable, make sure the cut surface is 90° flush and the wire is not damaged.

Next insert the wire into the contact well. Try to make it so the cable insulation just touches the contact well. Then look to see if the cable conductor is past the observation hole of the contact well. Finally, use a crimping tool (see appendix 1) to crimp the contact.

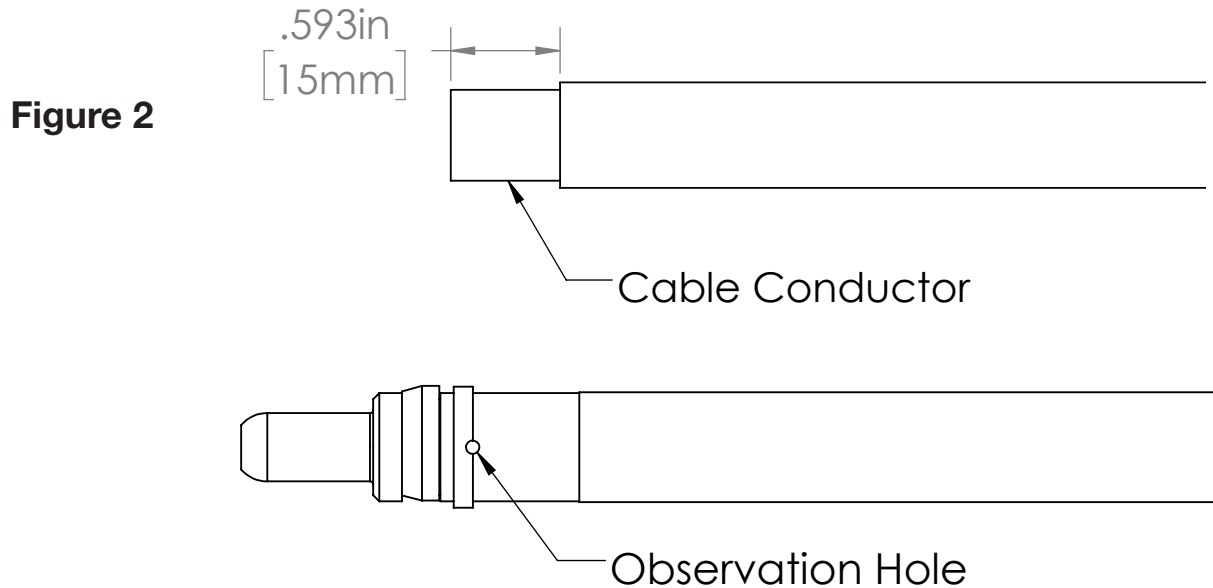

3) Assemble Connector

Assemble the crimped contacts into the insert by pushing firmly in place to the point where they cannot be pulled out. Then push the grommet, sleeve and adapter forward to finish assembly.

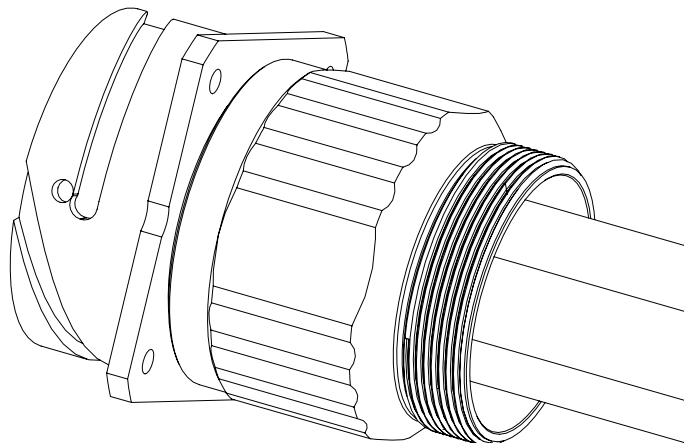

Appendix

Appendix 1: Recommend Crimp Tool

Crimp Tool	Positioner/Die Set	Locator
Pico 400BH31	Pico 41431A-0N	Pin 4042-1
		Socket 4042

Appendix 2: Recommend Installation Torque

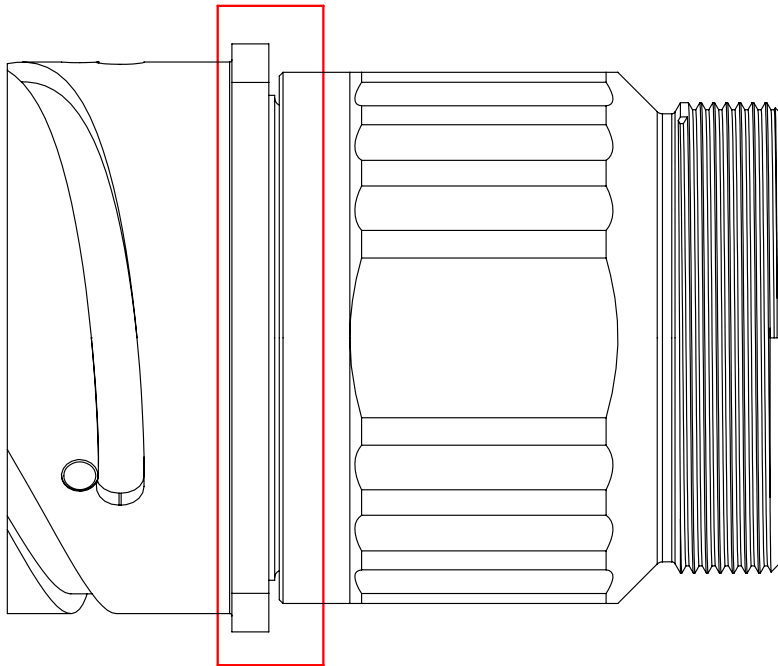

The recommended installation torque for the part in the red box as shown in the Figure is 160~170 Lbs. (The Plug connector is the same as the Receptacle Connector)

Appendix 3: Extraction Tool Part Number: CE-EXTRACT-00

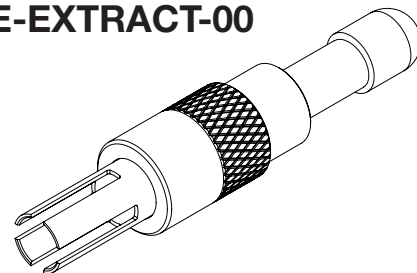

3. Revision History

Revision	Description	Date	Owner
A	Initial Release	2021/11/9	Bruce Lee