

## Product Configuration

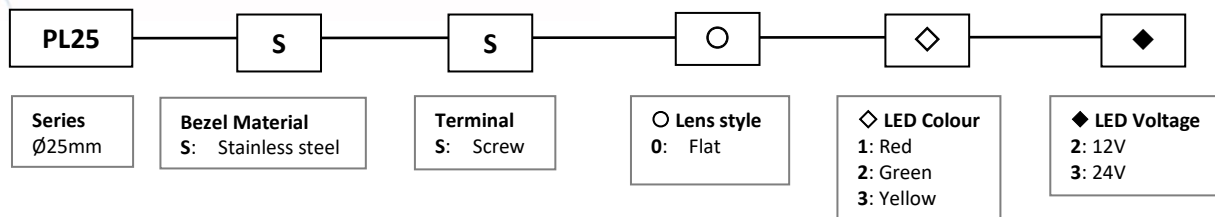

### Example Part Number

PL25SS023 Panel indicator 25mm diameter, stainless steel bezel, screw terminals, Flat lens, Green, 24V.

## Outline Dimensions (mm) - Not to scale

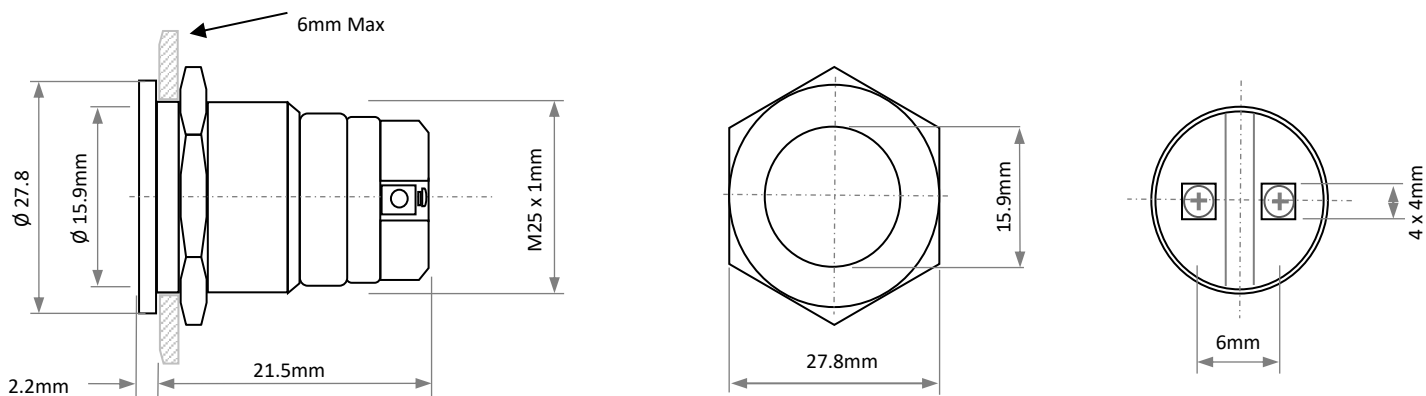

Colour	Typ. Wavelength (nm)	Viewing Angle (°)	Typ. Current (mA)	Typ. Luminous Intensity (mcd)
Red	622	110	20	896
Green	518	110	20	1680
Yellow	590	110	20	896

### Notes:

- 1 **Optical Data** Applies to component LED
- 2 **Body Material** Stainless Steel 304
- 2 **LED Life (Average)** 50000 Hrs
- 4 **Current Rating** ≤ 20mA
- 5 **Protection** IP67
- 6 **Environmental** RoHS & REACH SVHC compliant