



EV6545-F-00A

45V, 2.5A, Simple Three-Phase Power Stage in a TSSOP-28EP Package Evaluation Board

DESCRIPTION

The EV6545-F-00A evaluation board is designed to demonstrate the capabilities of the MP6545, a three-phase power stage. It can be used to drive brushless DC (BLDC) motors and other loads.

The MP6545 can operate from a supply input voltage (V_{IN}) of up to 45V, and can deliver load currents up to 2.5A per phase.

The MP6545 has separate high-side (HS) and low-side (LS) input pins for each output pin. The input control signals can be generated on the board or can come from an external controller via the connector on the board.

The MP6545 is available in a TSSOP-28EP package. It is recommended to read the MP6545 datasheet before making any changes to the EV6545-F-00A.

PERFORMANCE SUMMARY ⁽¹⁾

Specifications are at $T_A = 25^\circ\text{C}$, unless otherwise noted.

Parameters	Conditions	Value
Input voltage (V_{IN}) range		4.5V to 45V
Maximum output current (I_{OUT})		2.5A

EV6545-F-00A EVALUATION BOARD

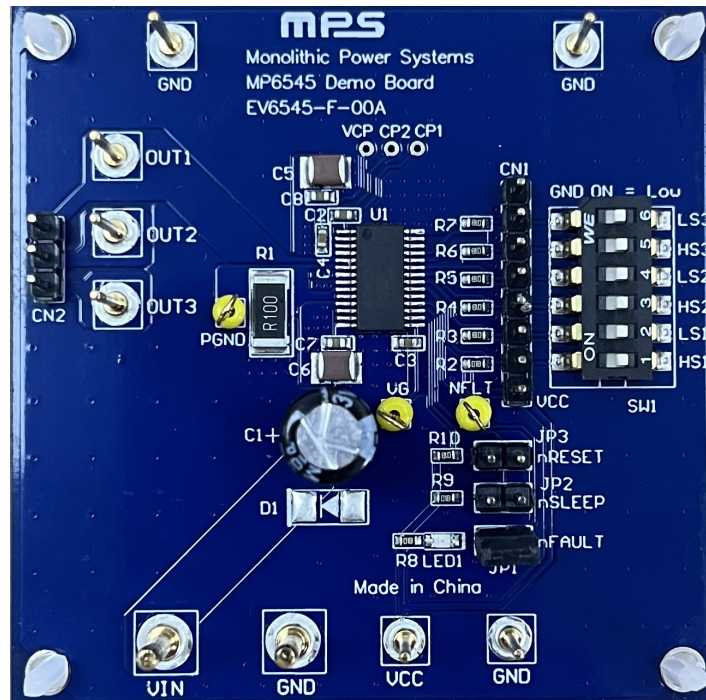

LxW (6.35cmx6.35cm)

Board Number	MPS IC Number
EV6545-F-00A	MP6545GF

QUICK START GUIDE

1. Preset the input power supply (V_{IN}) between 4.5V and 45V.
2. Connect the input power supply terminals to:
 - a. Positive (+): VIN
 - b. Negative (-): GND
3. Preset the VCC supply (V_{CC}) to 3.3V or 5V.
4. Connect the VCC supply terminals to:
 - a. Positive (+): VCC
 - b. Negative (-): GND
5. Set the input control and logic signal through the CN1 connector via the external MCU, or manually through SW1. Table 1 shows the input logic for the high-side (HSx) and low-side (LSx) inputs.

Table 1: Input Logic Truth

HSx	LSx	OUTx
0	0	Hi-Z
0	1	L
1	0	H
1	1	Hi-Z

EVALUATION BOARD SCHEMATIC

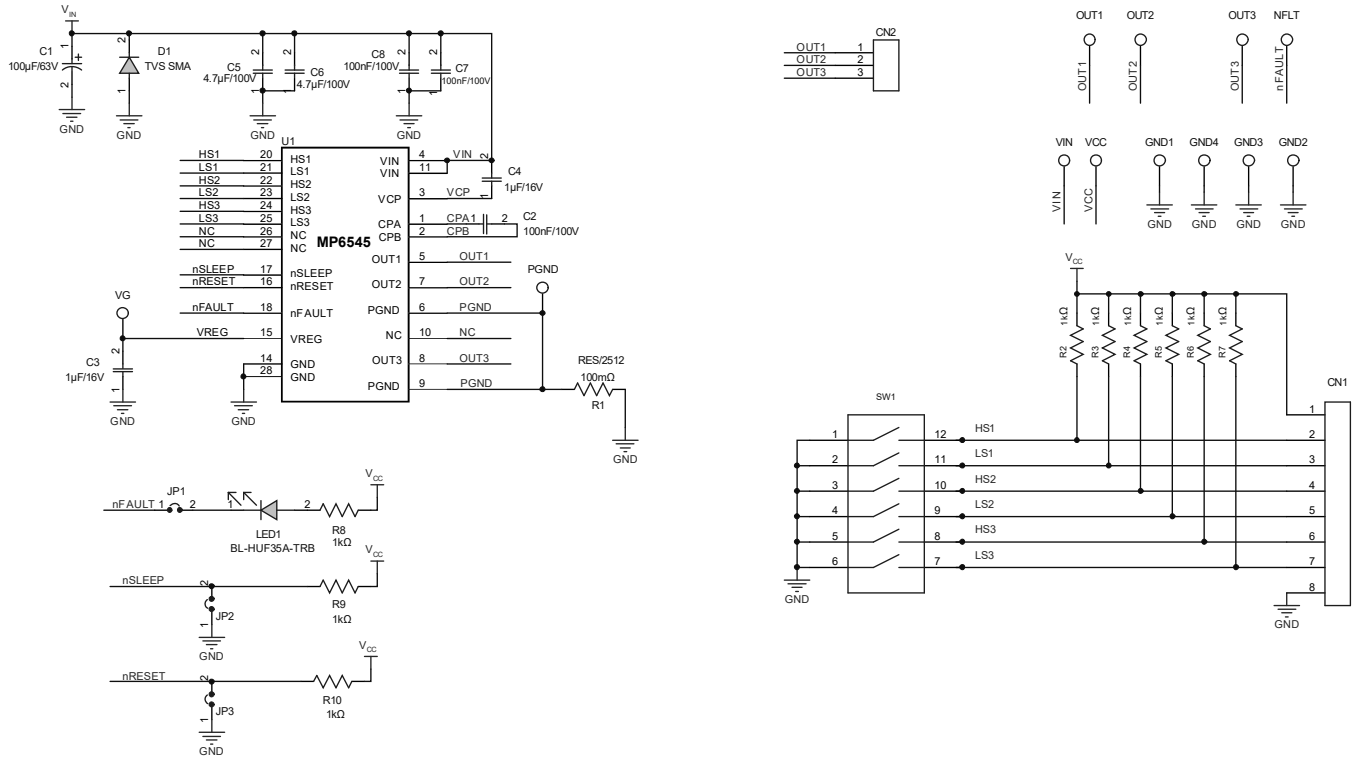

Figure 1: Evaluation Board Schematic

EV6545-F-00A BILL OF MATERIALS

Qty	Ref	Value	Description	Package	Manufacturer	Manufacture PN
1	C1	100µF	Electrolytic capacitor, 63V	DIP	Rubycon	63PX100MEFC8X11.5
3	C2, C7, C8	100nF	Ceramic capacitor, 100V, X7R	0603	Würth	885012206120
2	C3, C4	1µF	Ceramic capacitor, 16V, X7R	0603	Murata	GRM188R71C105KA12D
2	C5, C6	4.7µF	Ceramic capacitor, 100V, X7S	1210	TDK	C3225X7S2A475K
9	R2, R3, R4, R5, R6, R7, R8, R9, R10	1kΩ	Film resistor, 1%	0603	Yageo	RC0603FR-071KL
1	R1	100mΩ	Film resistor, 1%	2512	Yageo	RL2512FK-070R1L
1	LED1	20mA	LED	0805	Baihong	BL-HUE35A-AV-TRB
1	D1	NS				
1	SW1	25mA	Button	SMD	Würth	418121270808
1	CN1	2.54mm	Connector	DIP	Any	
1	CN2	2.54mm	Connector	DIP	Any	
3	JP1, JP2, JP3	2.54mm	Connector	DIP	Any	
1	JP1	2.54mm	Short jumper	DIP	Any	
3	VG, NFLT, PGND	1mm	Test point	DIP	Any	
2	VIN, GND	2mm	Connector	DIP	Any	
7	VCC, GND, OUT1, OUT2, OUT3, GND, GND	1mm	Connector	DIP	Any	
1	U1	MP6545	45V, 2.5A, simple three-phase power stage	TSSOP-28EP	MPS	MP6545GF

PCB LAYOUT

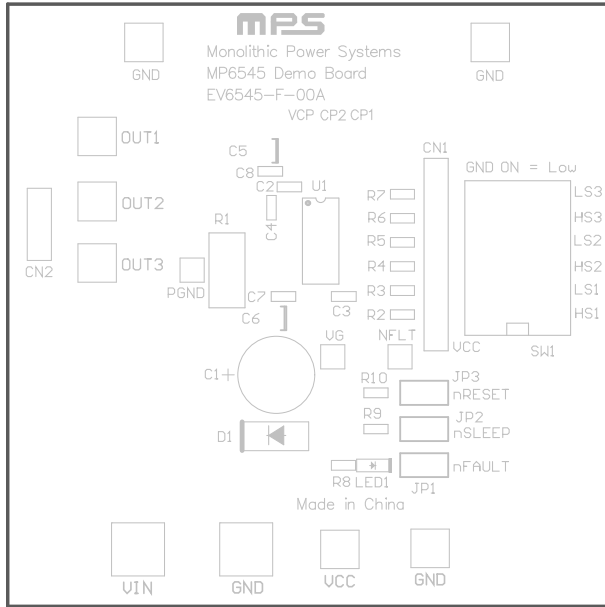

Figure 2: Top Silk

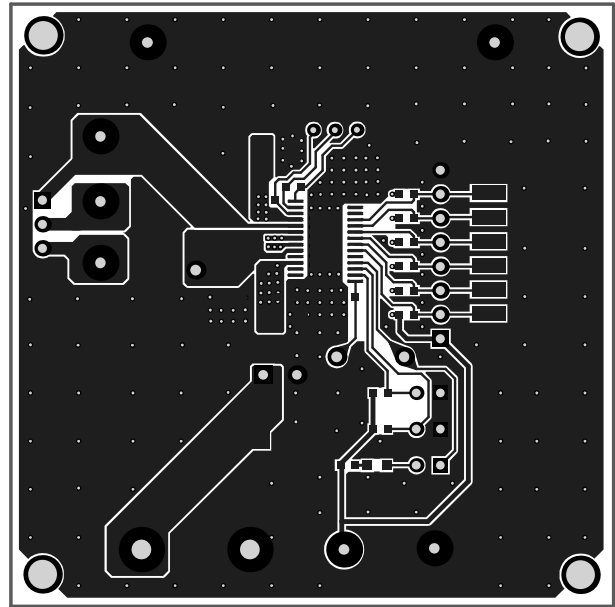

Figure 3: Top Layer

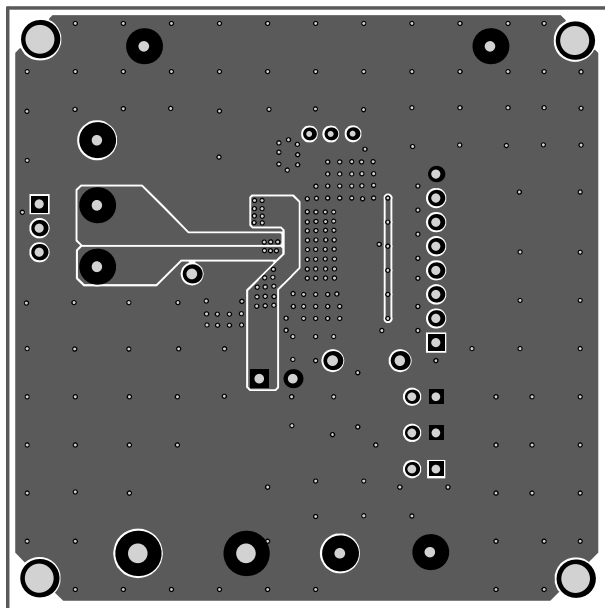

Figure 4: Bottom Layer

REVISION HISTORY

Revision #	Revision Date	Description	Pages Updated
1.0	8/5/2022	Initial Release	-
1.1	10/11/2023	Updated the pin numbers in the Evaluation Board Schematic	3

Notice: The information in this document is subject to change without notice. Please contact MPS for current specifications. Users should warrant and guarantee that third-party Intellectual Property rights are not infringed upon when integrating MPS products into any application. MPS will not assume any legal responsibility for any said applications.