

THIS IS ISSUED IN STRICT CONFIDENCE THAT IT IS NOT USED AS A BASIS FOR MANUFACTURE OR SALE AND THAT IT IS NOT COPIED, REPRINTED OR DISCLOSED TO A THIRD PARTY EITHER WHOLLY OR IN PART WITHOUT THE PRIOR WRITTEN CONSENT OF CAL TEST ELECTRONICS, INC.

NOTE:

- MATERIAL:**
 - BODY, CAP & INNER INSULATOR: NYLON 6.6 (PA), UL94-1, COLORS: BODY & INNER INSULATOR, GREY: CAP, PER MODEL NUMBER.
 - CONTACT, PANEL NUT & ACCESSORIES: BRASS, C36000, NICKEL PLATED.
- SPECIFICATIONS:**
 - VOLTAGE: 100 V CAT II P2, PER IEC/EN 61010-1.
 - CURRENT: 36 A MAX.
 - OPERATING TEMPERATURE: 0°C TO +60°C.
- CROSS-HOLE ALLIGNED ±3° PERPENDICULAR TO MOUNTING FLATS.**
- MAXIMUM PANEL THICKNESS: 9 mm.**
- MAXIMUM TIGHTENING TORQUE ON M12 PANEL NUT: 2.3 N.m. (1.70 FT-LBF).**
- RECOMMENDED ASSEMBLY TOOL: CT2246.**
- HARDWARE INCLUDED (1 EACH):**
 - PANEL NUT (CT2830)
 - M4 FLAT WASHER
 - M4 LOCK WASHER
 - M4 HEX NUT
- ROHS 2 COMPLIANT: EXEMPTION ANNEX III 6(C).**
- WEIGHT: 18.3 GRAMS.**

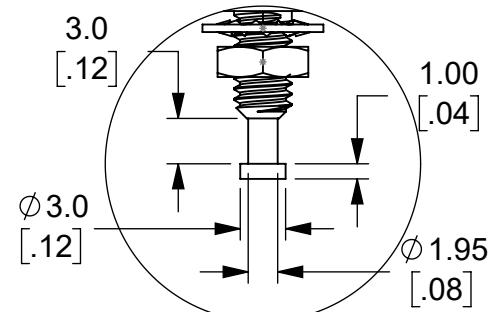

DETAIL B
SCALE 2 : 1
(SOLDER TURRET)

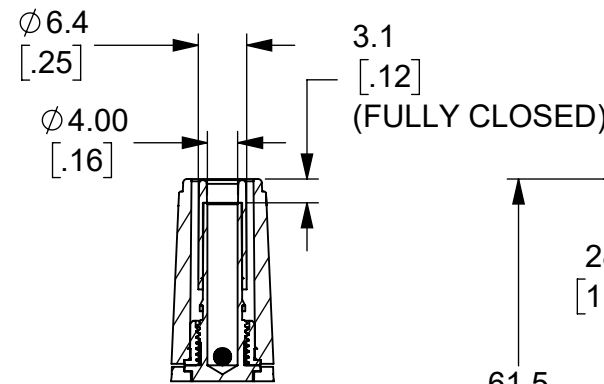

SECTION A-A

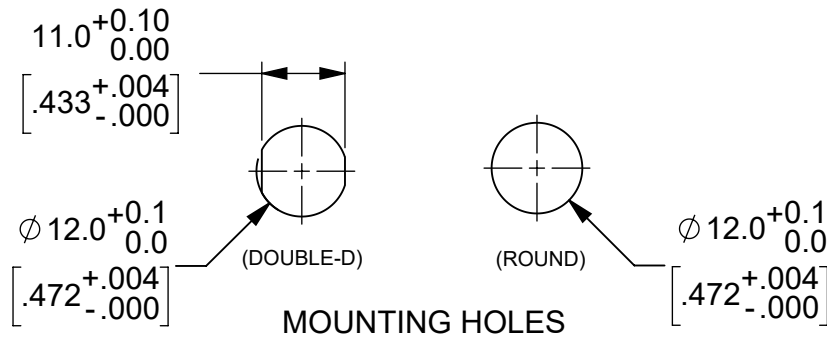
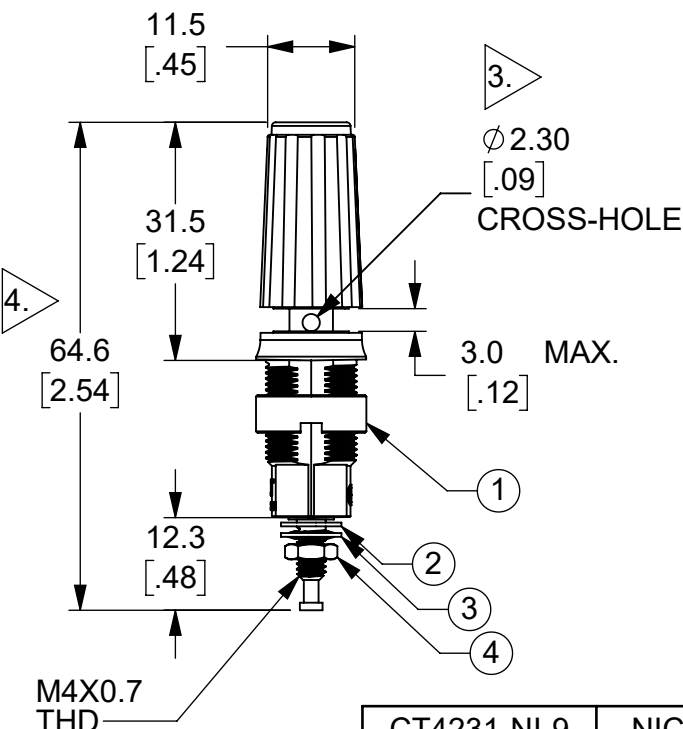
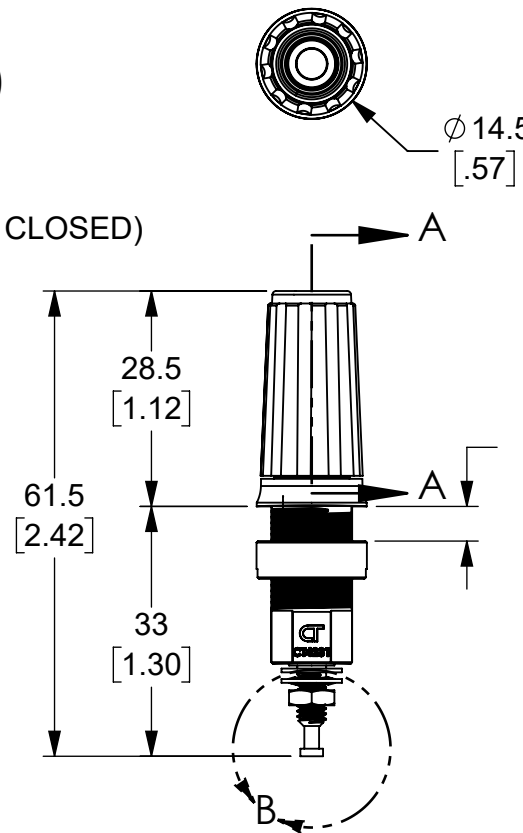

ISOMETRIC VIEW

REVISIONS			
REV.	DESCRIPTION	DATE	APPROVED
A	CLASS A RELEASE	5/14/2019	
B	NOTE 2., VOLTAGE: UPDATED BASED ON LVD TESTING, WAS 600 V *NO RATED MEASUREMENT CATEGORY	7/30/2019	
C	UPDATED TO LATEST B SIZE DWG FORMAT; DWG WAS P423100 REV. B; ADDED 3 MODEL COLORS YELLOW, BLUE, & WHITE; MINOR TEXT CORRECTIONS.	8/30/2023	B. HANSEN

CT4231-NI-9	NICKEL PLATED	WHITE
CT4231-NI-6	NICKEL PLATED	BLUE
CT4231-NI-5	NICKEL PLATED	GREEN
CT4231-NI-4	NICKEL PLATED	YELLOW
CT4231-NI-2	NICKEL PLATED	RED
CT4231-NI-0	NICKEL PLATED	BLACK
MODEL NUMBER	CONFIGURATION/PLATING	CAP COLOR

MODEL NUMBER TABLE

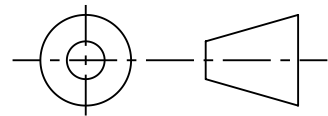
THIRD ANGLE PROJECTION		UNLESS OTHERWISE SPECIFIED DIMENSIONS ARE IN MILLIMETERS TOLERANCES ARE: X.X = ±0.5 X.X* = ±0.5* X.XX = ±0.25 X.XXX = ±0.125 DO NOT SCALE DRAWING	PROJECT NO.	METRIC		 22820 Savi Ranch Prky. Yorba Linda, CA 92887 USA
			MATERIAL SEE NOTES	C368	APPROVALS	
REFERENCE		TREATMENT NONE		DRAWN WDH	5/1/2019	4mm SHEATHED BINDING POST, PANEL MOUNT
		FINISH SEE NOTES		CHECKER G Gorgonio	8/30/2023	
				ENGR. B. Hansen	5/14/2019	SIZE B
				DESIGN ACTIVITY		CAGE CODE 43F45
						DWG. NO. CT4231
						REV. C
						SCALE 1:1
						SHEET 1 OF 1