

ebm-papst Mulfingen GmbH & Co. KG

Bachmühle 2 · D-74673 Mulfingen

Phone +49 7938 81-0

Fax +49 7938 81-110

info1@de.ebmpapst.com

www.ebmpapst.com

Limited partnership · Headquarters Mulfingen

Amtsgericht (court of registration) Stuttgart · HRA 590344

General partner Elektrobau Mulfingen GmbH · Headquarters Mulfingen

Amtsgericht (court of registration) Stuttgart · HRB 590142

Nominal data

Type	A2D210-AB10-05		
Motor	M2D068-CF		
Phase		3~	3~
Nominal voltage	VAC	400	480
Wiring		Y	Y
Frequency	Hz	50	60
Method of obtaining data		cs	cs
Valid for approval/standard		CE	CE
Speed (rpm)	min ⁻¹	2750	3250
Power consumption	W	89	130
Current draw	A	0.26	0.27
Min. ambient temperature	°C	-25	-25
Max. ambient temperature	°C	-	-

ml = Max. load · me = Max. efficiency · fa = Free air · cs = Customer specification · ce = Customer equipment
Subject to change



Technical description

Weight	1.62 kg
Size	210 mm
Motor size	68
Rotor surface	Painted black
Blade material	Sheet steel, painted black
Number of blades	5
Airflow direction	V
Direction of rotation	Counterclockwise, viewed toward rotor
Degree of protection	IP44; installation- and position-dependent as per EN 60034-5
Insulation class	"F"
Moisture (F) / Environmental (H) protection class	H1+
Max. permitted ambient temp. for motor (transport/storage)	+ 80 °C
Min. permitted ambient temp. for motor (transport/storage)	- 40 °C
Installation position	Shaft horizontal or rotor on bottom; rotor on top on request
Condensation drainage holes	On rotor side
Mode	S1
Motor bearing	Ball bearing
Touch current according to IEC 60990 (measuring circuit Fig. 4, TN system)	< 0.75 mA
With cable	Lateral
Protection class	I (with customer connection of protective earth)
Conformity with standards	EN 60335-1; CE; UKCA
Approval	CCC; UL 1004-1; EAC; CSA C22.2 No. 100

Product drawing

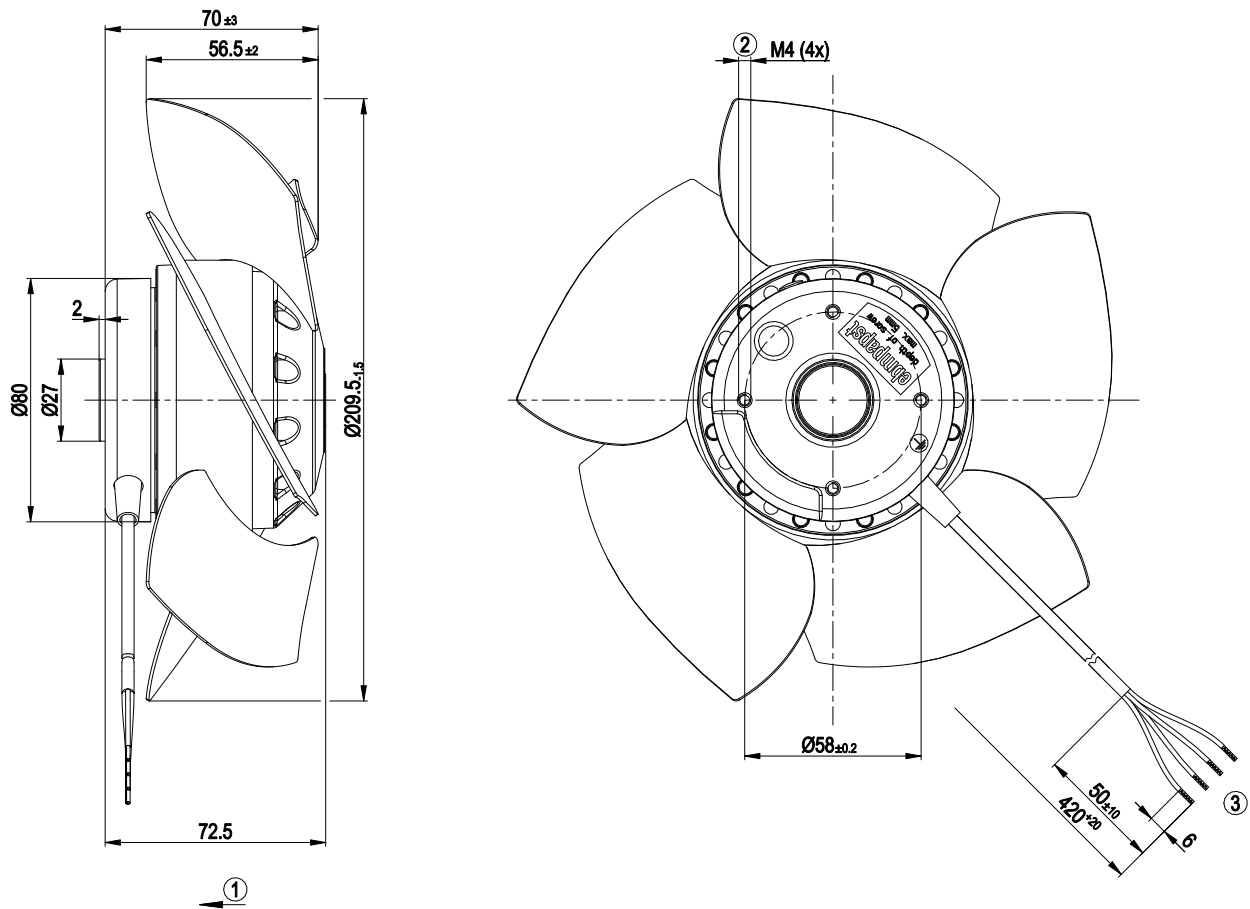

1	Direction of air flow "V"
2	Max. clearance for screw 5 mm
3	Cable PFA AWG20 (green/yellow AWG18), 4x crimped splices
	Accessory parts, included separately:
	Grommet
	4x M4x8 cheese-head screws, tightening torque 2.2 ± 0.2 Nm

Connection diagram

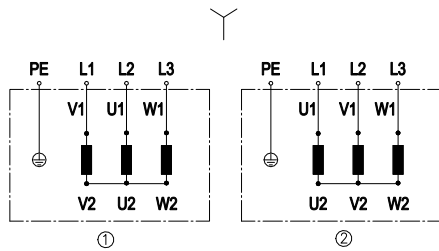

Change of rotation direction by reversing two phases

	Three-phase motor
Y	Star connection
1	Counterclockwise operation
L1	= V1 = blue
L2	= U1 = black
L3	= W1 = brown
2	Clockwise operation
L1	= U1 = black
L2	= V1 = blue
L3	= W1 = brown
PE	green/yellow

Curves: Air performance 50 Hz

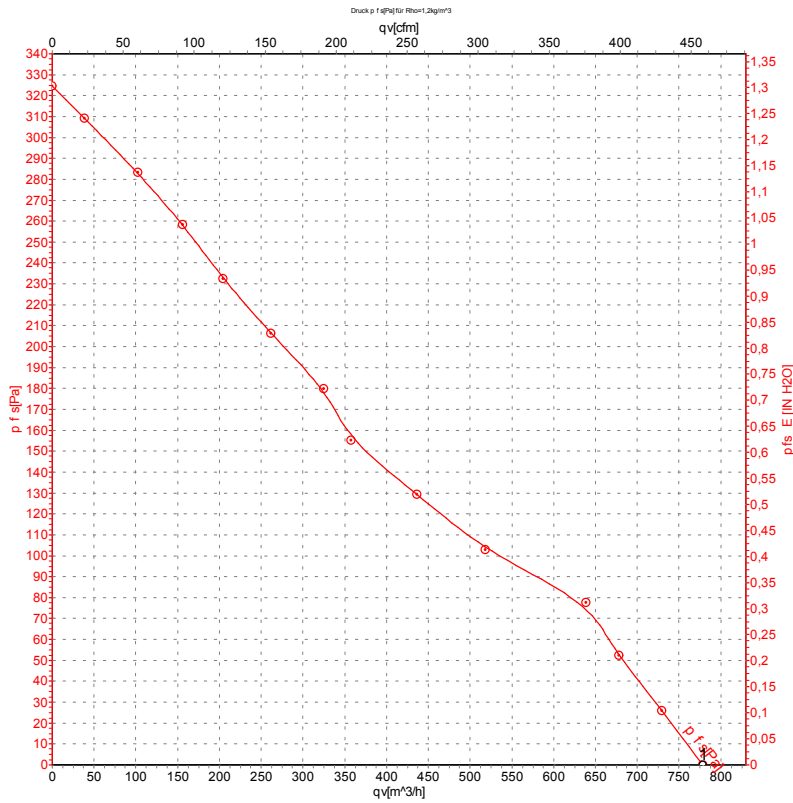

Measurement: LU-43914-1

Air performance measured according to ISO 5801 installation category A. For detailed information on the measurement setup, contact ebm-papst. Intake sound level: Sound power level according to ISO 13347 / sound pressure level measured at 1 m distance from fan axis. The values given are valid under the specified measuring conditions and may vary due to conditions of installation. For deviations from the standard configuration, the parameters have to be checked on the installed unit.

Measured values

	U	f	n	P _e	I	q _v	q _v	P _{fs}
	V	Hz	min ⁻¹	W	A	m ³ /h	cfm	in. wg
1	400	50	2750	89	0.26	780	460	0.00

U = Voltage · f = Frequency · n = Speed (rpm) · P_e = Power consumption · I = Current draw · q_v = Air flow



Curves: Air performance 60 Hz

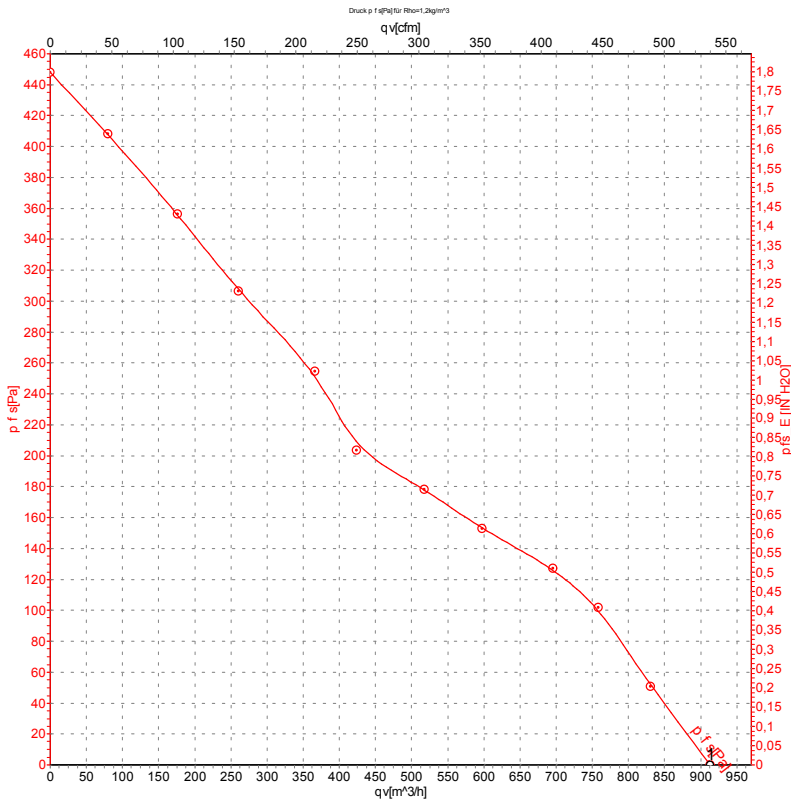

Measurement: LU-42528-1

Air performance measured according to ISO 5801 installation category A. For detailed information on the measurement setup, contact ebm-papst. Intake sound level: Sound power level according to ISO 13347 / sound pressure level measured at 1 m distance from fan axis. The values given are valid under the specified measuring conditions and may vary due to conditions of installation. For deviations from the standard configuration, the parameters have to be checked on the installed unit.

Measured values

	U	f	n	P _e	I	q _v	q _v	p _{fs}
	V	Hz	min ⁻¹	W	A	m ³ /h	cfm	in. wg
1	480	60	3250	130	0.27	915	535	0.00

U = Voltage · f = Frequency · n = Speed (rpm) · P_e = Power consumption · I = Current draw · q_v = Air flow

