

RMD300-UW Series / Plug & Play Railway

300W / Ultra-Wide Input 24V-110VDC

FEATURES

- Fully EN50155 compliant, no external circuits
- Ultra-wide input range 12:1 reduces product variety
- Excellent efficiency, lowest power loss, full lifetime
- Full power up to +85° without heat sink, no derating
- Active input reverse polarity protection
- Active inrush current limitation - network protection
- 10ms hold-up time over the entire input range
- Reinforced insulation, 6mm air/creepage distances
- Trim-output for long cable runs or battery charging
- Parallel and redundant operation
- 10% Peak load capability for 10s
- Remote (on/off) and DC OK with relay changer
- 2 years warranty



Dimensions (LxWxH): 209.0 x 141.0 x 48.0mm (8.23 x 5.55 x 1.89 inch)
1100g (2.43 lbs)

APPLICATIONS

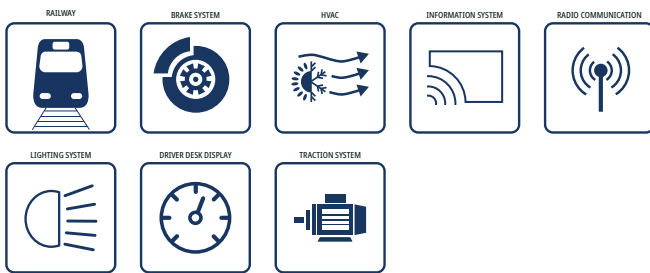

SAFETY & EMC



DESCRIPTION

The chassis mountable RMD300 series DC/DC converter is designed for railway rolling stock and transportation applications and is compliant with all relevant standards: EN50155, EN50121-3-2, DB-EMV06, EN50124-1, EN50125-1, EN61373 1B, EN62368-1, EN45545-2. The unit is designed with 12:1 input voltage range to cover the input voltages from 14.4VDC up to 170VDC for nominal 24, 36, 48, 72 and 110V in one range with isolated and regulated 24V output and reinforced insulation system. The base plate mounting permits a wide operating temperature for OT4+ST1&ST2 class from -40°C to +85°C without derating. Input reverse polarity protection, inrush current limitation, 10ms hold-up time, remote control, and output OR-ing diode and efficiency of up to 94.8% round up the functionality of this fully railway compliant Plug&Play unit.

SELECTION GUIDE

Part Number	Input Voltage Range [VDC]	Output Voltage nom. [VDC]	Output Current max. ⁽¹⁾ [A]	Efficiency typ. [%]	Output Power max. ⁽¹⁾ [W]
RMD300-110-24SUW ⁽²⁾	16.8-137.5	24	13.75	94	330
RMD300-110-110SUW ⁽²⁾ *coming soon	16.8-137.5	110	3	94	330

Note1: refer to „Peak Load Capability“

MODEL NUMBERING

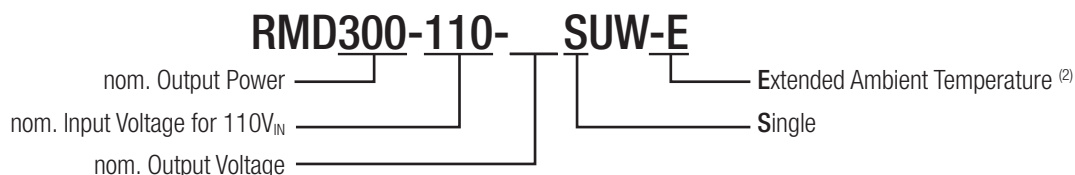

Note2: add suffix "-E" for extended ambient temperature range (-50°C..+90°C) *coming soon
without suffix= standard operating range (-40°C..+90°C)

RMD300-UW Series / Plug & Play Railway

300W / Ultra-Wide Input 24V-110VDC

BASIC CHARACTERISTICS (measured @ $T_{AMB}= 25^{\circ}C$, nom. V_{IN} , full load and after warm-up unless otherwise stated)

Parameter	Conditions		Min.	Typ.	Max.
Input Voltage Range	refer to „Input Voltage Range“	nom. $V_{IN}= 24, 36, 48, 72, 110VDC$	16.8VDC		137.5VDC
		according to EN 50155	100ms max	14.4VDC	16.8VDC
			1s max.	137.5VDC	154VDC
Input Surge Voltage	3s max. (extended to EN 50155)				170VDC
Input Capacitance	internal			11 μ F	
Under Voltage Lockout	rising edge		14.5VDC		15.5VDC
	falling edge		13.5VDC		14.4VDC
Input Current	$V_{IN}=16.8VDC$			19.8A	
	$V_{IN}= 24VDC$			13.6A	
	$V_{IN}= 110VDC$			2.9A	
Inrush Current	active inrush current limitation (<3.5 x I_{nom})				30A
No Load Power Consumption	$V_{IN}= 24VDC$			7.1W	
	$V_{IN}= 110VDC$			7.3W	
Standby Current (shutdown by remote)	$V_{IN}=16.8VDC$			21.4mA	
	$V_{IN}= 24VDC$			14.8mA	
	$V_{IN}= 110VDC$			7.2mA	
	$V_{IN}= 137.5VDC$			7mA	
Output Current Range	RMD300-110-24SUW	continuous operation	0A		12.5A
		10s max. refer to „Peak Load Capability“			13.75A
	RMD300-110-110SUW	continuous operation	0A		2.73A
		10s max. refer to „Peak Load Capability“			3A
Output Voltage	RMD300-110-24SUW			24VDC	
	RMD300-110-110SUW			110VDC	
Output Voltage Trimming	refer to „Output Voltage Trimming“	RMD300-110-24SUW	19.2VDC		25.2VDC
		RMD300-110-110SUW	88VDC		115.5VDC
Minimum Load			0%		
Start-up time	$V_{IN}= 24VDC$				1s
	$V_{IN}= 110VDC$				0.6s
	by using CTRL ON/OFF function				0.3s
Rise time					100ms
Hold-up time	$V_{IN}=16.8VDC$			10ms	
	$V_{IN}= 24VDC$			20ms	
	$V_{IN}= 110VDC$			20ms	
ON/OFF CTRL	DC-DC ON		high/open or $12VDC < V_{CTRL} < 154VDC$		
	DC-DC OFF (pin15 INH connected pin16 INH0)		low or $-2VDC < V_{CTRL} < 2VDC$		
Input Current of CTRL pin	DC-DC ON				10mA
Internal Operating Frequency				70kHz	
Output Ripple and Noise	over full input and load range, 20MHz BW				50mVp-p
Maximum Capacitive Load	constant current mode			50mF	

BASIC CHARACTERISTICS (measured @ $T_{AMB} = 25^{\circ}C$, nom. V_{IN} , full load and after warm-up unless otherwise stated)

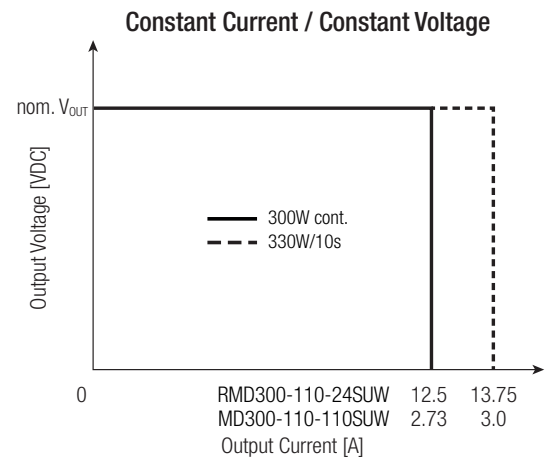
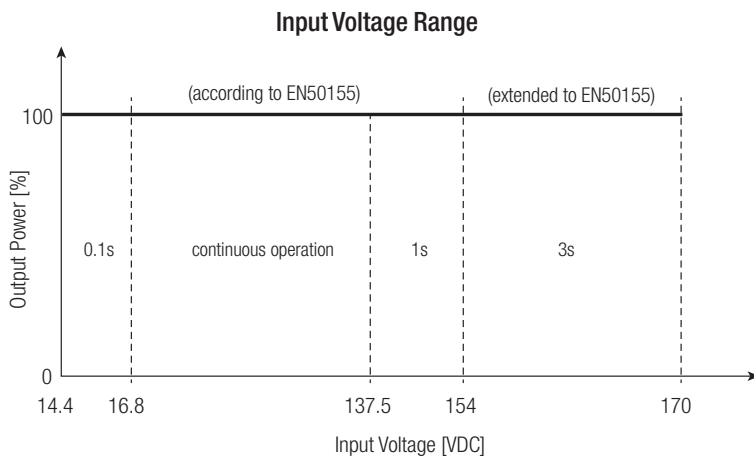

RMD300-110-24SUW

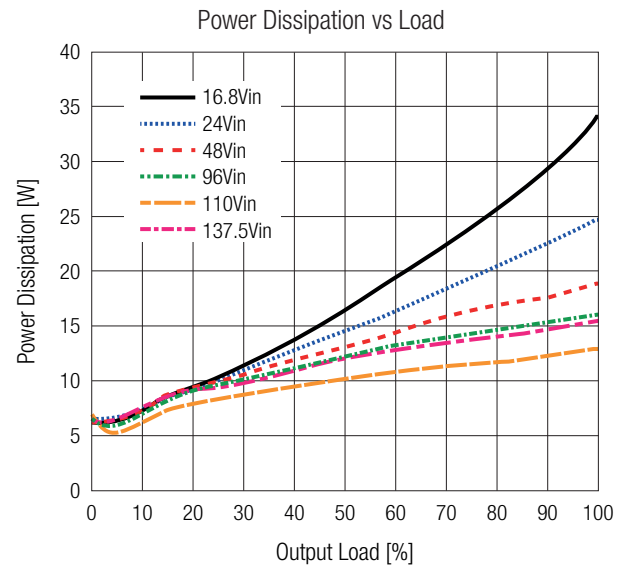
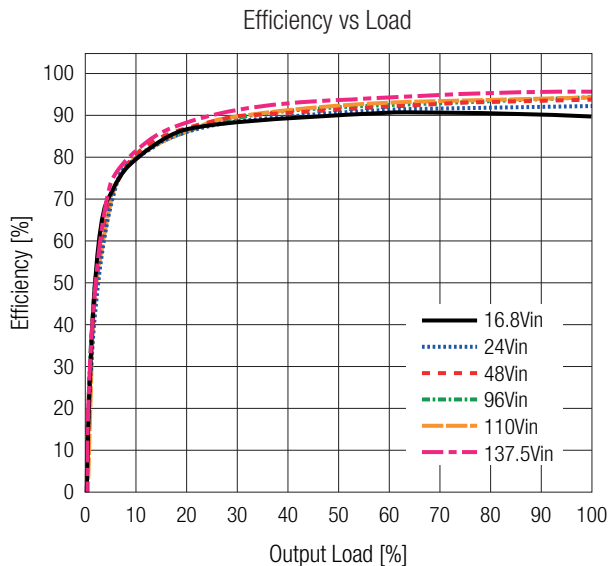

PEAK LOAD CAPABILITY

Peak power capability supports short power peaks of dynamic loads like motors, relays, storage devices or computer booting sequences. In addition allowing faster charge of load sided capacitors and reliable circuit breaker operation.

- P_{nom} = nominal output power [W]
- P_p = peak output power (330W max) [W]
- P_r = recovery power [W]
- t_1 = peak time (10s max) [s]
- t_2 = recovery time (calculated) [s]

Calculation:

$$t_2 = \frac{(P_{nom} - P_p) \times t_1}{P_r - P_{nom}}$$

Practical Example:

- $P_{nom} = 300W$
- $P_p = 330W$
- $P_r = 280W$
- $t_1 = 10s$

$$t_2 = \frac{(300W - 330W) \times 10s}{280W - 300W} = 15s$$

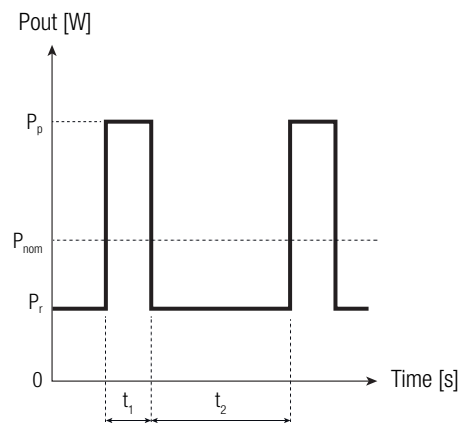

OUTPUT VOLTAGE TRIMMING

The output voltage of the RMD300-UW can be trimmed between +5% and -20% by using an external trim resistor. The values for the trim resistor are according to standard E96 values; therefore, the specified voltage may slightly vary. Resistor values may be calculated with the following equation:

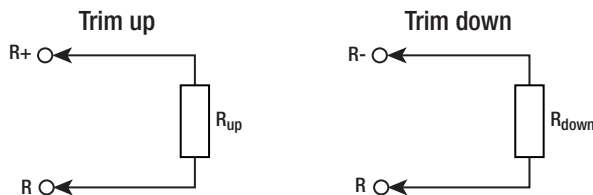

Calculations:

- $V_{out_{nom}}$ = nominal output voltage [VDC]
- $V_{out_{set}}$ = trimmed output voltage [VDC]
- R_{up} = trim up resistor [Ω]
- R_{down} = trim down resistor [Ω]

$$R_{up} \cong \frac{322k\Omega \times V_{OUTnom} - 306k\Omega \times V_{OUTset}}{V_{OUTset} - V_{OUTnom}}$$

$$R_{down} \cong \frac{20k\Omega \times V_{OUTset} - 16k\Omega \times V_{OUTnom}}{V_{OUTnom} - V_{OUTset}}$$

Practical Example trim up +5% for RMD300-110-24SUW

$$R_{up} = \left[\frac{322k\Omega \times 24V - 306k\Omega \times 25.2V}{25.2V - 24V} \right] = 14000\Omega$$

R_{up} according to E96 \approx 14k Ω

Practical Example trim down -10% for RMD300-110-24SUW

$$R_{down} = \left[\frac{20k\Omega \times 21.6V - 16k\Omega \times 24V}{24V - 21.6V} \right] = 20000\Omega$$

R_{down} according to E96 \approx 20k Ω

RMD300-110-24SUW

Trim up	1	2	3	4	5	[%]
$V_{out_{set}} =$	24.24	24.48	24.72	24.96	25.2	[VDC]
R_{up} (E96) \approx	1M3	499k	226k	93k1	14k	[Ω]

Trim down	-1	-2	-3	-4	-5	-6	-7	-8	-9	-10	[%]
$V_{out_{set}} =$	23.76	23.52	23.28	23.04	22.8	22.56	22.32	22.08	21.84	21.6	[VDC]
R_{down} (E96) \approx	383k	182k	113k	80k6	60k4	46k4	37k4	30k1	24k3	20k	[Ω]

Trim down	-11	-12	-13	-14	-15	-16	-17	-18	-19	-20	[%]
$V_{out_{set}} =$	21.36	21.12	20.88	20.64	20.4	20.16	19.92	19.68	19.44	19.2	[VDC]
R_{down} (E96) \approx	16k2	13k3	10k7	8k45	6k65	4k99	3k48	2k21	1k05	0	[Ω]

RMD300-110-110SUW

Trim up	1	2	3	4	5	[%]
$V_{out_{set}} =$	111.1	112.2	113.3	114.4	115.5	[VDC]
R_{up} (E96) \approx	1M3	499k	226k	93k1	14k	[Ω]

Trim down	-1	-2	-3	-4	-5	-6	-7	-8	-9	-10	[%]
$V_{out_{set}} =$	108.9	107.8	106.7	105.6	104.5	103.4	102.3	101.2	100.1	99	[VDC]
R_{down} (E96) \approx	383k	182k	113k	80k6	60k4	46k4	37k4	30k1	24k3	20k	[Ω]

Trim down	-11	-12	-13	-14	-15	-16	-17	-18	-19	-20	[%]
$V_{out_{set}} =$	97.9	96.8	95.7	94.6	93.5	92.4	91.3	90.2	89.1	88	[VDC]
R_{down} (E96) \approx	16k2	13k3	10k7	8k45	6k65	4k99	3k48	2k21	1k05	0	[Ω]

REGULATIONS (measured @ $T_{AMB} = 25^{\circ}C$, nom. V_{IN} , full load and after warm-up unless otherwise stated)

Parameter	Conditions	Value
Output Accuracy		$\pm 1.0\%$ max.
Line Regulation	low line to high line, full load	0.1%
Load Regulation	10%-100% load	0.1% typ.
Transient Response	10-90% load, $V_{IN} = 16.8-137VDC$	0.5VDC
	recovery time	40ms typ.

RMD300-UW Series / Plug & Play Railway

300W / Ultra-Wide Input 24V-110VDC



PROTECTIONS (measured @ $T_{AMB} = 25^{\circ}\text{C}$, nom. V_{IN} , full load and after warm-up unless otherwise stated)

Parameter	Type		Value
Internal Input Fuse			T30A, slow blow type
Short Circuit Protection (SCP)	constant current mode, auto recovery	RMD300-110-24SUW	>110% of nom. output current
		RMD300-110-110SUW	>110-125% of nom. output current
Short Circuit Input Current	$V_{IN} = 24\text{VDC}$		0.8A typ.
	$V_{IN} = 110\text{VDC}$		0.4A typ.
Input Reverse Polarity Protection	active protected		-137.5VDC
Over Voltage Protection (OVP)	latch off	RMD300-110-24SUW	28.8VDC - 32.5VDC
		RMD300-110-110SUW	132VDC-148.5VDC
Over Voltage Category (OVC)	according to EN 50124-1:2018		OVC III
Over Current Protection (OCP)	auto recovery	RMD300-110-24SUW	>110%-125% of nom. output current
		RMD300-110-110SUW	>110%-135% of nom. output current
Over Temperature Protection (OTP)	shut down, auto recovery		$T_{AMB} > 90^{\circ}\text{C}$
Class of Equipment			Class I
Isolation Coordination	according to EN 50124-1:2018		$V_{NOM} = 300\text{VDC}$
Isolation Voltage ⁽³⁾	DC tested / AC rated	I/P to O/P	5kVDC / 3.5kVAC
		I/P to PE and O/P to PE	3kVDC / 2kVAC
	routine test	I/P to O/P, 10 seconds	2.8kVDC
		for 10 seconds on safety components	I/P to O/P I/P to PE and O/P to PE
Isolation Resistance			100MΩ max.
Isolation Capacitance			650pF max.
Leakage Current			10μA
Insulation Grade			reinforced
Internal Clearance	I/P to O/P		6mm
	I/P to PE		4mm
	O/P to PE		3mm

Note3: For repeat Hi-Pot testing, reduce the time and/or the test voltage

POWER GOOD

Parameter	Type		Value
Power OK LED	RMD300-110-24SUW	$V_{OUT} > 17\text{VDC}$	green
		$V_{OUT} < 17\text{VDC}$	light off
	RMD300-110-110SUW	$V_{OUT} > 80\text{VDC}$	green
		$V_{OUT} < 80\text{VDC}$	light off
Relay Status	RMD300-110-24SUW	$V_{OUT} > 17\text{VDC}$	OK: OK2 connected OK or OK1 not connected OK
		$V_{OUT} < 17\text{VDC}$	NOK: OK1 connected to OK or OK2 not connected OK
	RMD300-110-110SUW	$V_{OUT} > 80\text{VDC}$	OK: OK2 connected OK or OK1 not connected OK
		$V_{OUT} < 80\text{VDC}$	NOK: OK1 connected to OK or OK2 not connected OK
Relay Capability			0.5A/150VDC

ENVIRONMENTAL (measured @ $T_{AMB} = 25^{\circ}\text{C}$, nom. V_{IN} , full load and after warm-up unless otherwise stated)

Parameter	Conditions		Value
Operating Ambient Temperature Range	according to EN 50155 operating temperature class OT4 and extended operating temperature class ST1 & ST2	with derating	-40°C to +90°C
		without derating	-40°C to +70°C
		without derating for 15 minutes	-40°C to +85°C
Maximum Baseplate Temperature			+95°C
Temperature Coefficient			0.2%/K
Operating Altitude	according to EN 50124-1:2018		2000m (OVC III)
			5000m (OVC II)
Operating Humidity	non-condensing		95% RH max.

RMD300-UW Series / Plug & Play Railway

300W / Ultra-Wide Input 24V-110VDC

ENVIRONMENTAL (measured @ $T_{AMB} = 25^{\circ}C$, nom. V_{IN} , full load and after warm-up unless otherwise stated)

Conformal Coating ⁽⁴⁾	according to EN 50155		Class PC2
Pollution Degree			PD2
IP Rating			IP20
Design Lifetime			20 years
MTBF	according to IEC61709/ UTE C80-810	$T_{AMB} = +40^{\circ}C$	1360×10^3 hours
		$T_{AMB} = +55^{\circ}C$	850×10^3 hours
Useful Life Class	according to EN50155:2018 (S1)		L4

Note4: The board is protected on both sides with a protective / transparent / fluorescent / coating. The coating is compliant with class 2, according to IPC-A-610G: 2017

Derating Graph

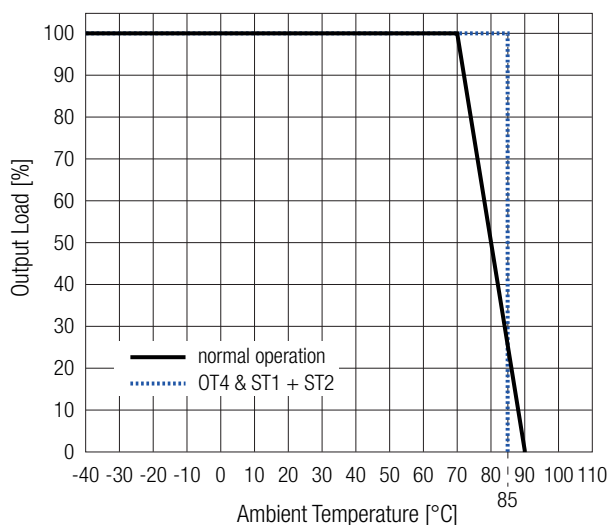

ENVIRONMENTAL (RAILWAY STANDARDS)

Parameter	Conditions	Value
Low Temperature start-up test	Temperature: $-40^{\circ}C$ Stabilization time 2h	EN 60068-2-1 (Ad)
Dry heat test	Temperature: $+70^{\circ}C$ Continuous operational checks time 6h	EN 60068-2-2 (Be) – Cycle A
Low temperature storage test	Temperature: $-40^{\circ}C$ Low temperature exposition time 16h	EN 60068-2-1 (Ab)
Cyclic damp heat test	Temperature: $+70^{\circ}C/+25^{\circ}C$ Number of cycles: 2 Time 2x 24h	EN 60068-2-30 (Db)
Simulated long-life testing	Random Vibration, unit not powered during test Frequency range 5-150Hz with -6db/oct from 20 to 150Hz Vertical axis $5.72m/s^2$ for 5h [ASD $0.964(m/s^2)^2/Hz$] Transverse axis $2.55m/s^2$ for 5h [ASD $0.192(m/s^2)^2/Hz$] Longitudinal axis $3.96m/s^2$ for 5h [ASD $0.461(m/s^2)^2/Hz$]	EN 61373 clause 9, class B Body mounted
Shock testing	Half-sine shock, unit powered during test Vertical axis $30m/s^2$ for 30ms Transverse axis $30m/s^2$ for 30ms Longitudinal axis $50m/s^2$ for 50ms Number of shocks: 18 (3x polarity for each axis)	EN 61373 clause 10, class B Body mounted
Functional random vibration test	Random Vibration, unit powered during test Frequency range 5-150Hz with -6db/oct from 20 to 150Hz Vertical axis $1.01m/s^2$ for 10min [ASD $0.0301(m/s^2)^2/Hz$] Transverse axis $0.45m/s^2$ 10min [ASD $0.006(m/s^2)^2/Hz$] Longitudinal axis $0.7m/s^2$ 10min [ASD $0.0144(m/s^2)^2/Hz$]	EN 61373 clause 8, class B Body mounted
Fire Protection on Railway Vehicles		EN45545-2 Hazard Level HL1 - HL3

SAFETY & CERTIFICATIONS (110VOUT PENDING)

Certificate Type (Safety)		Standard
Audio/video, information and communication technology equipment. Safety requirements		IEC/EN62368-1:2020+A11:2020
Railway applications - Insulation coordination - Part 1: Basic requirements - Clearances and creepage distances for all electrical and electronic equipment		EN50124-1
Railway Applications - Electrical Equipment used on rolling stock		EN50155
RoHS2		RoHS 2011/65/EU + AM2015/863

EMC Compliance	Conditions	Standard / Criterion
Railway applications - Electromagnetic compatibility		EN50121-3-2:2016+A1:2019
Electromagnetic compatibility (EMC) - Part 6-4: Generic standards - Emission standard for industrial environments		EN61000-6-4:2007+A1:2011
ESD Electrostatic discharge immunity test	Air: $\pm 2, 4, 8kV$ Contact: $\pm 2, 4, 6kV$	IEC61000-4-2:2009, Criteria A EN61000-4-2:2008, Criteria A
Radiated, radio-frequency, electromagnetic field immunity test	20V/m (80-1000MHz) 10V/m (1000-2000MHz)	IEC/EN61000-4-3:2006, Criteria A
Fast Transient and Burst Immunity	DC Power Port: $\pm 2kV$	IEC/EN61000-4-4:2012, Criteria A
Surge Immunity	DC Power Port: $\pm 0.5, 1kV$ line sym. DC Power Port: $\pm 0.5, 1, 2kV$ line unsym.	IEC/EN61000-4-5:2014, Criteria A
Immunity to conducted disturbances, induced by radio-frequency fields	10Vr.m.s. (0.15-80MHz)	IEC/EN61000-4-6: 2016, Criteria A
Railway applications - Electromagnetic compatibility		EN50121-3-2:2016+A1:2019
Technische Regeln zur Elektromagnetischen Verträglichkeit: Nachweis der Funkverträglichkeit von Schienenfahrzeugen mit Bahnfunkdiensten		Regelung Nr. EMV 06:2019

DIMENSION & PHYSICAL CHARACTERISTICS

Parameter	Type	Value
Material	case	aluminum
Dimension (LxWxH)		209.0 x 141.0 x 48.0mm 8.23 x 5.55 x 1.89 inch
Weight		1100g typ. 2.43 lbs

Dimension Drawing (mm)

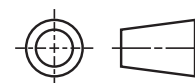
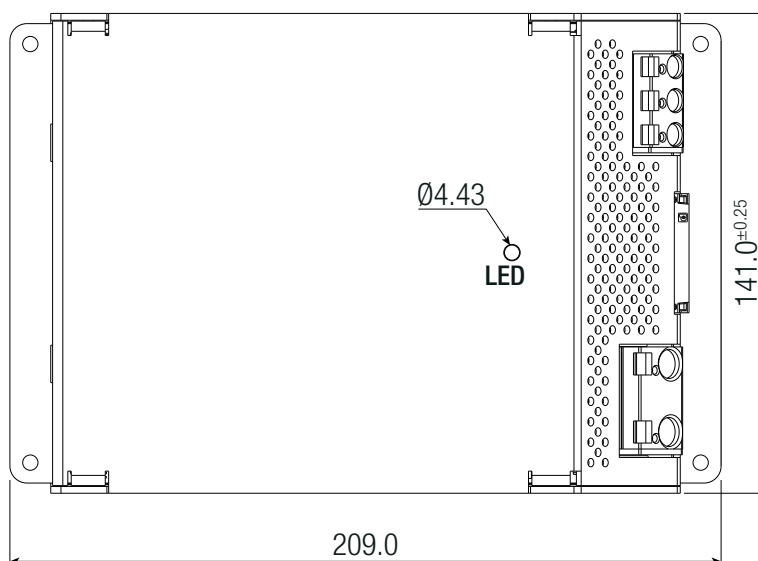

Tolerance Table	
Dimension range	Tolerances
0.5 - 6 mm	± 0.1 mm
6 - 30 mm	± 0.2 mm
30 - 120 mm	± 0.3 mm
120 - 315 mm	± 0.5 mm

FC = fixing centers

DIMENSION & PHYSICAL CHARACTERISTICS

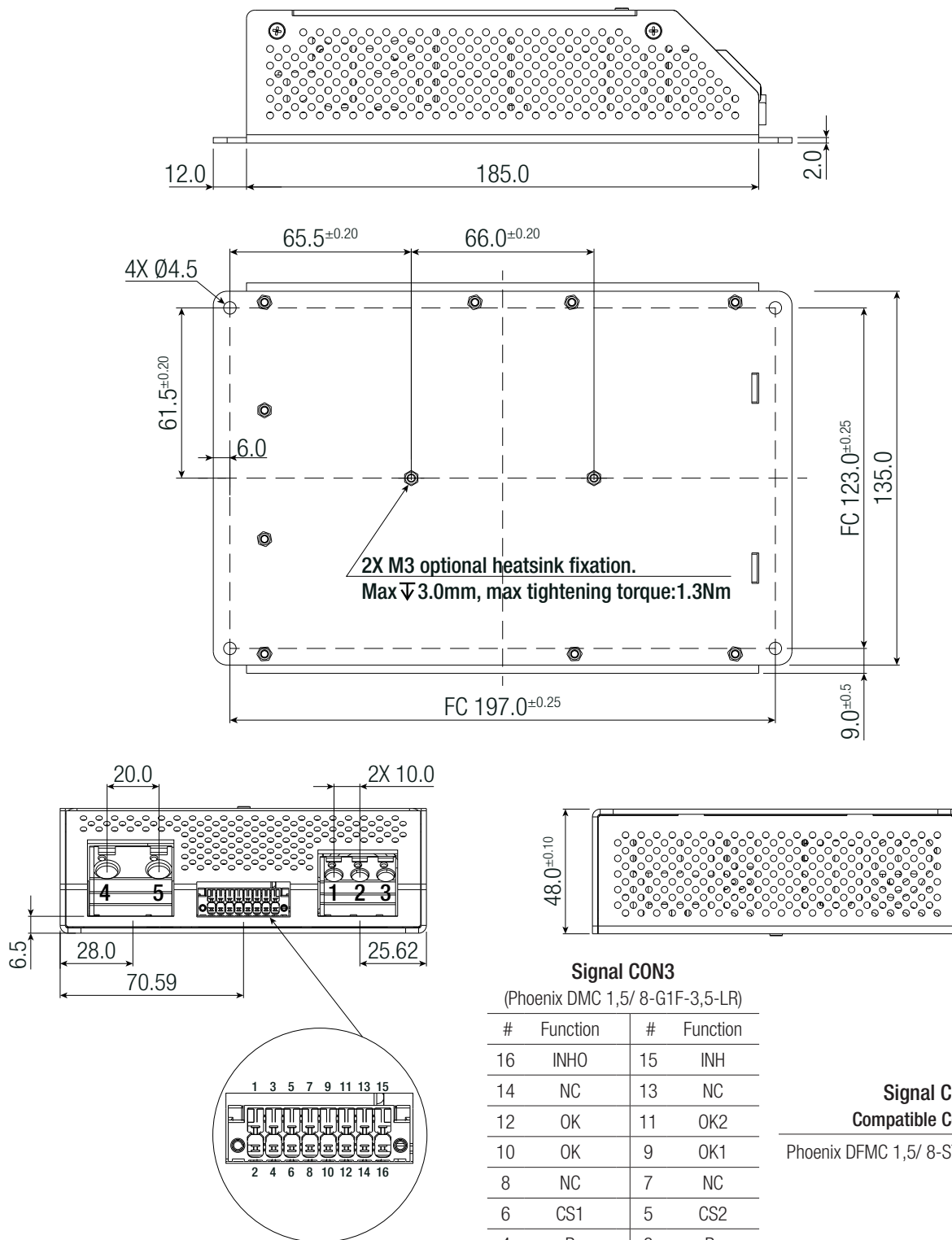

Input connector CAGE CLAMP® CON1 (WAGO 745-353)

#	Function	AWG	Wire diameter
1	-Vin	24-10	0.25-4mm ²
2	+Vin	24-10	0.25-4mm ²
3	PE	24-10	0.25-4mm ²

wire stripping length: 11-12mm

Conductor connection direction to PCB 45°

Output connector CAGE CLAMP® CON2 (WAGO 745-602/006-000)

#	Function	AWG	Wire diameter
4	+Vout	24-6	0.25-10mm ²
5	-Vout	24-6	0.25-10mm ²

wire stripping length: 12-13mm

Conductor connection direction to PCB: 45°

Tolerance Table	
Dimension range	Tolerances
0.5 - 6 mm	±0.1 mm
6 - 30 mm	±0.2 mm
30 - 120 mm	±0.3 mm
120 - 315 mm	±0.5 mm

FC = fixing centers

INSTALLATION & APPLICATION

Mounting Instructions

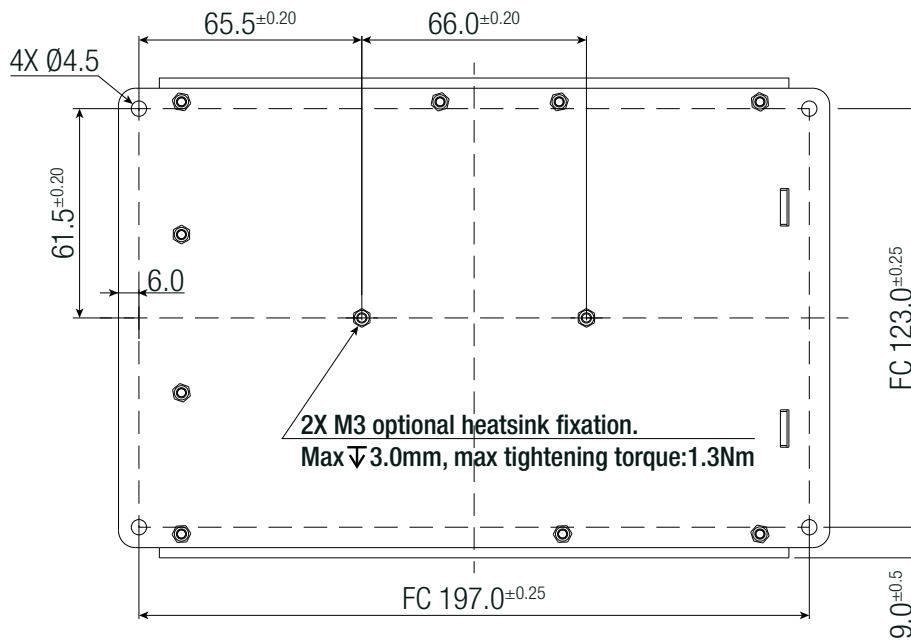

For operation of the DC/DC converter the PE connection at the intended connection point as part of the overall EMC concept is mandatory.

Natural air convection around the unit must be possible at any time and the temperature shall not be exceeded.

The RMD converter has to be installed with 4 x M4 screws and can be mounted in any mounting direction.

All control and signal terminals have been tested and have passed the requirements according to the EN50121-3-2 regulations, nevertheless for installation conditions with cable lengths above 30m, maybe additional protection against disturbances will be necessary.

INSTALLATION & APPLICATION

Parallel Operation

Here the example of three parallel connected units. CS1/CS2 is a double connection of the same pin to be able to connect more than two units.

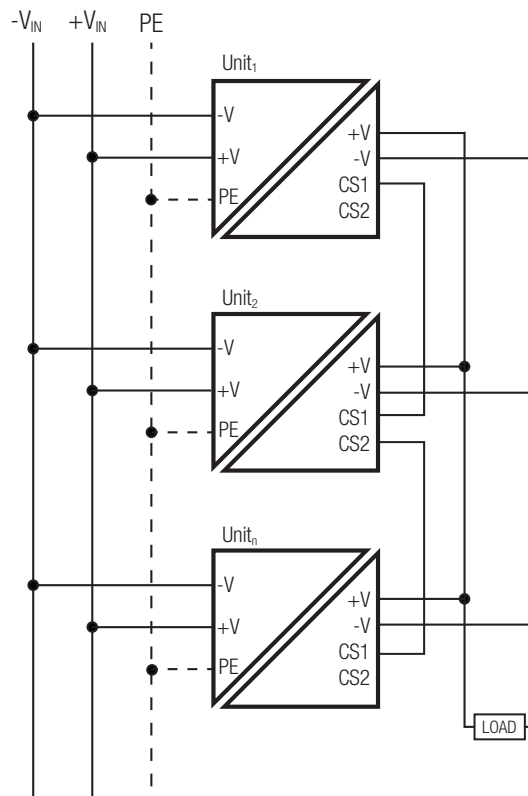

BLOCK DIAGRAM

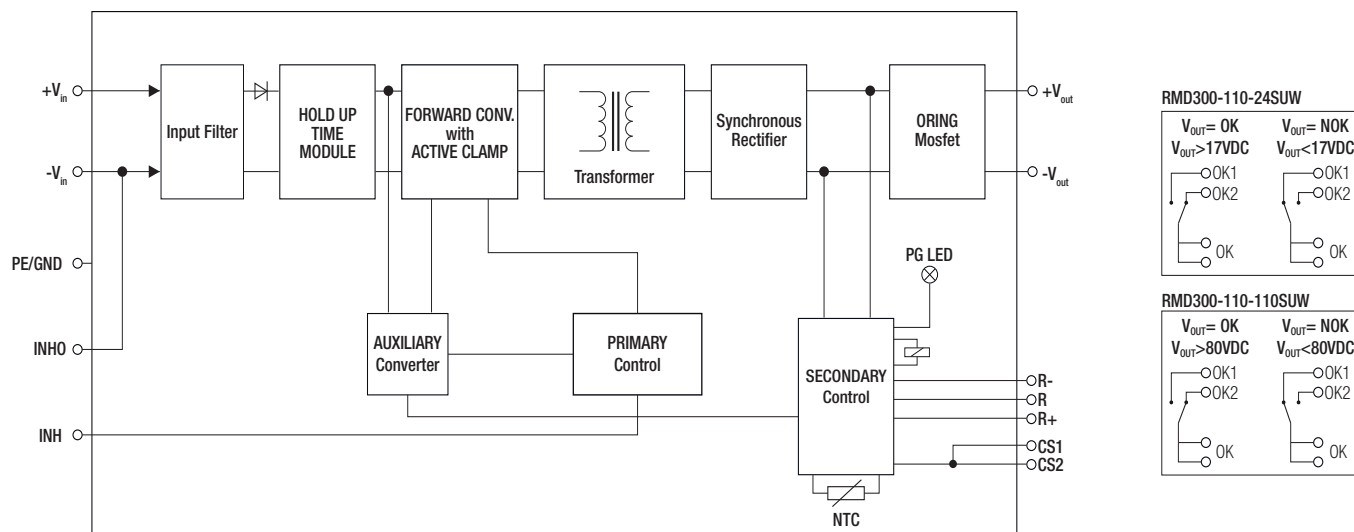

PACKAGING INFORMATION

Parameter	Type	Value
Packaging Dimension (LxWxH)	cardboard box	145.0 x 53.0 x 218.0mm
Packaging Quantity		1pc
Storage Temperature Range		-40°C to +85°C

The product information and specifications may be subject to changes even without prior written notice. The product has been designed for various applications; its suitability lies in the responsibility of each customer. The products are not authorized for use in safety-critical applications without RECOM's explicit written consent. A safety-critical application is an application where a failure may reasonably be expected to endanger or cause loss of life, inflict bodily harm or damage property. The applicant shall indemnify and hold harmless RECOM, its affiliated companies and its representatives against any damage claims in connection with the unauthorized use of RECOM products in such safety-critical applications.