

SERIES 200A SWITCHES

TOGGLE SWITCHES - PROCESS SEALED SUB-MINIATURE

TACT SWITCHES

NAVIGATION SWITCHES

PUSHBUTTON SWITCHES

TOGGLE SWITCHES

ROCKER SWITCHES

SLIDE SWITCHES

SNAP-ACTION SWITCHES

DIP SWITCHES

KEYLOCK SWITCHES

ROTARY SWITCHES

DETECTOR SWITCHES

CAP OPTIONS

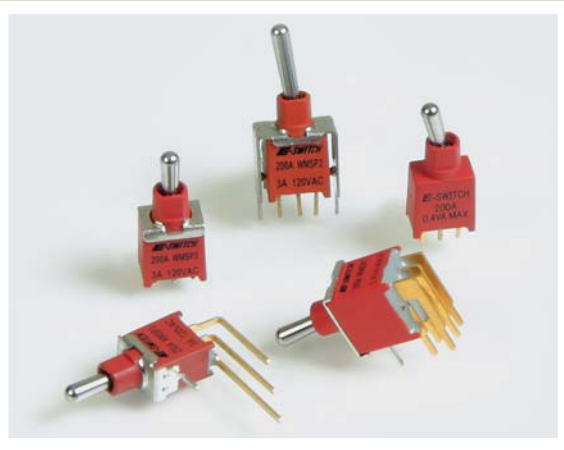

FEATURES & BENEFITS

- ▶ Variety of switching functions
- ▶ Sub-miniature
- ▶ Multiple actuator & bushing options
- ▶ Sealed to IP67

APPLICATIONS/MARKETS

- ▶ Telecommunications
- ▶ Instrumentation
- ▶ Networking
- ▶ Medical equipment

SPECIFICATIONS

Contact Rating:	Dependent on contact material
Life Expectancy:	50,000 make-and-break cycles at full load
Contact Resistance:	Below 20 m typ. initial @ 2-4 VDC, 100 mA, for both silver and gold plated contacts
Insulation Resistance:	1,000 MΩ min.
Dielectric Strength:	1,000 V RMS min. @ sea level
Operating Temperature:	-30° C to 85° C
Seal Rated:	IP67

MATERIALS

Case & Bushing:	Glass filled nylon, flame retardant, heat stabilized (UL 94-V0)
Actuator:	Brass, chrome plated, internal O-ring seal standard for all actuators
Switch Support:	Brass, tin plated
Contacts / Terminals:	Silver or gold plated copper alloy
Terminal Seal:	Epoxy

HOW TO ORDER

SERIES	MODEL NO.	ACTUATOR	BUSHING	TERMINATION	CONTACT MATERIAL	SEAL
200A	WMSP1 WMSP2 WMSP3 WMSP4 WMSP5 WMSP6* WMDP1 WMDP2 WMDP3	T1 T2 T3	A1	M2 M6 M61 M7 VS2	Q = Silver R = Gold	E = Epoxy Sealed at Base of Terminal

Example Ordering Number
200A-WMSP2-T1-A1-VS2-Q-E

*Only available with M2 or VS2 termination

Specifications subject to change without notice.4.21.2022

SPDT

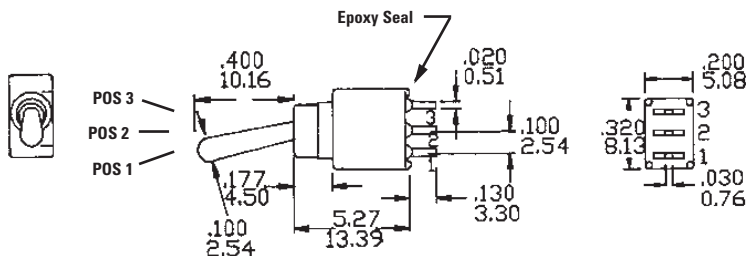

2 Comm.
1 3

SCHEMATIC

Model No.	POS 1	POS 2	POS 3
WMSP-1	ON	NONE	ON
WMSP-2	ON	NONE	(ON)
WMSP-3	ON	OFF	ON
WMSP-4	(ON)	OFF	(ON)
WMSP-5	ON	OFF	(ON)
Term. Comm.	2-3	OPEN	2-1
WMSP-6	OFF	NONE	ON
Term. Comm.	OPEN	NONE	3-1

() = Momentary



DPDT

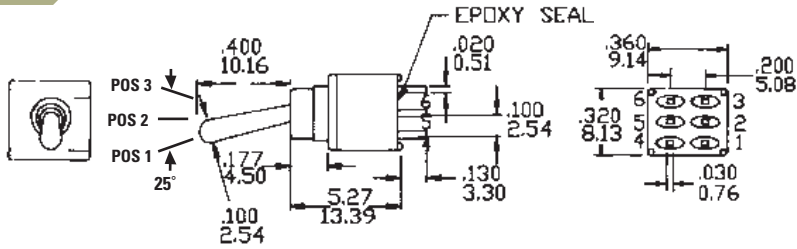

Model No.	POS 1	POS 2	POS 3
WMDP-1	ON	NONE	ON
WMDP-2	ON	NONE	(ON)
WMDP-3	ON	OFF	ON
Term. Comm.	2-3,5-6	OPEN	2-1,5-4

() = Momentary

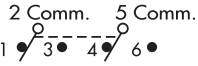

SCHEMATIC

ACTUATOR OPTIONS

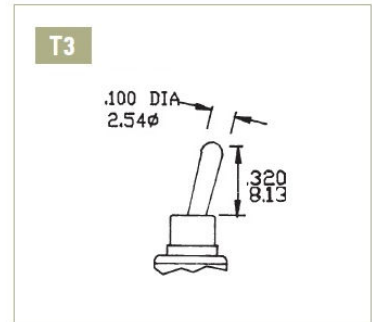
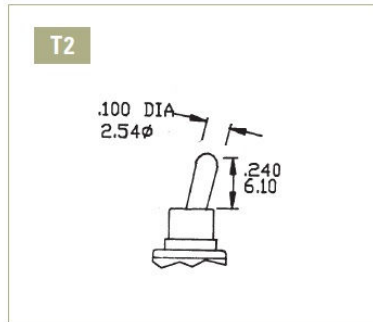
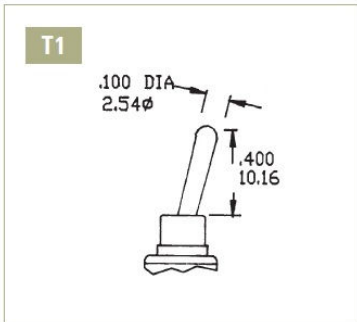

BUSHING OPTIONS

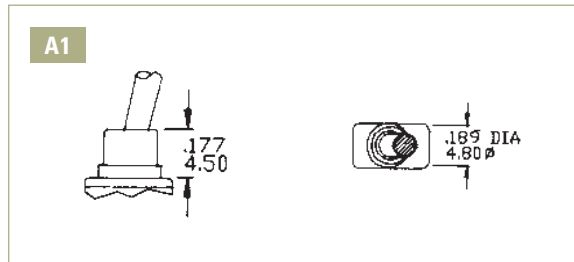

TERMINATION OPTIONS

M2

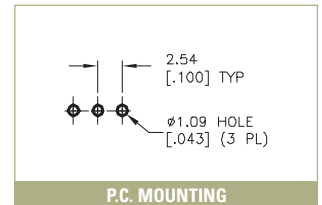
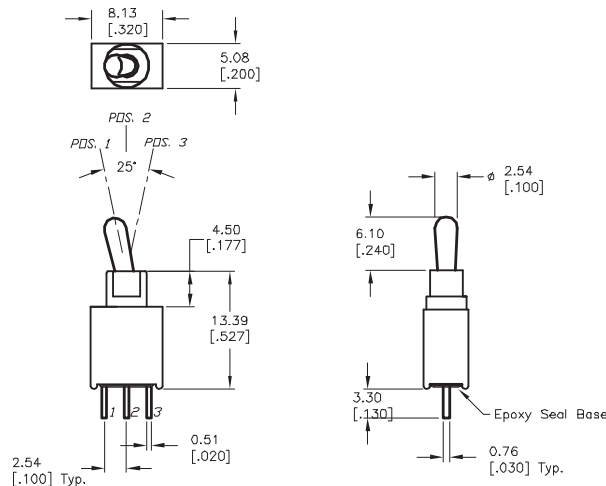

SERIES 200A SWITCHES

TOGGLE SWITCHES - PROCESS SEALED SUB-MINIATURE

TACT SWITCHES

NAVIGATION SWITCHES

PUSHBUTTON SWITCHES

M6

SPDT

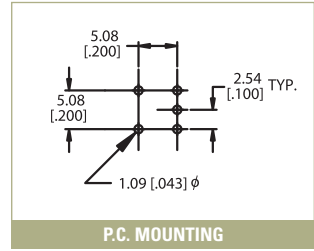
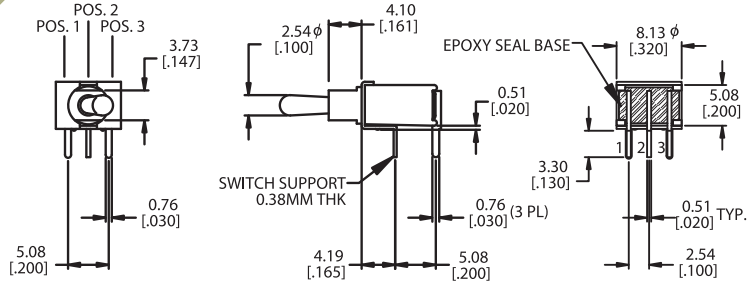

TOGGLE SWITCHES

ROCKER SWITCHES

SLIDE SWITCHES

M6

DPDT

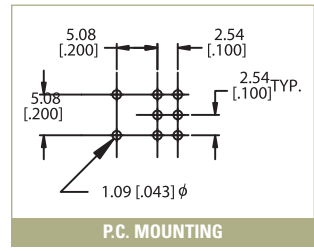
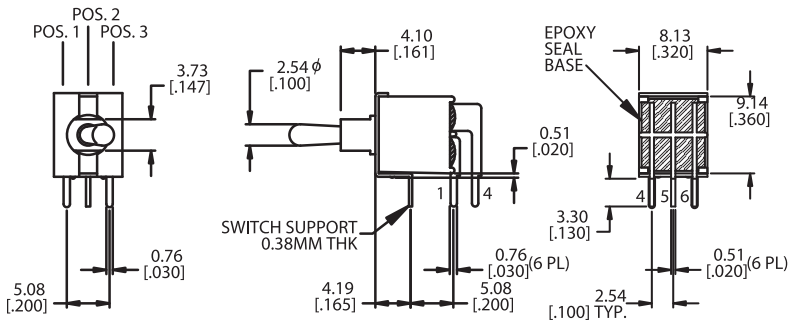

SNAP-ACTION SWITCHES

DIP SWITCHES

KEYLOCK SWITCHES

M61

SPDT
SNAP-IN BRACKET

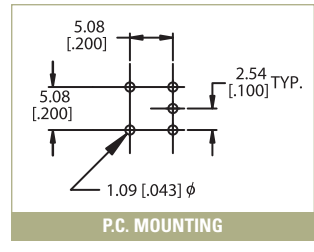
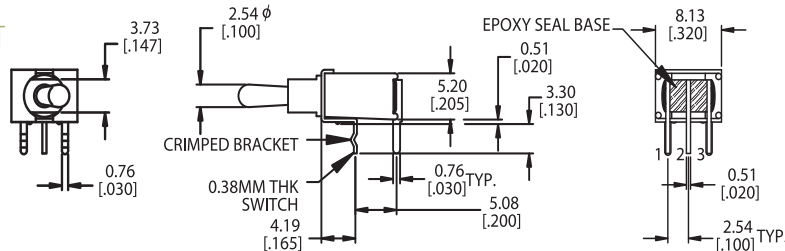

ROTARY SWITCHES

DETECTOR SWITCHES

CAP OPTIONS

M7

SPDT

