

ILD8150E high-efficiency reference design

REF_ILD8150E_HE

Headroom voltage control in high-efficiency two-stage LED drivers

About this document



Scope and purpose

The document shows how to enable headroom voltage control in LED drivers by combining an AC-DC flyback controller and a DC-DC buck converter, enhancing system performance and reducing design costs.

Secondary-side regulation (SSR) in LED drivers enables advanced features such as headroom voltage control. SSR is enabled by combining an AC-DC flyback controller (such as [XDPL8219](#) or [ICL8820](#)) and a DC-DC buck converter ([ILD8150](#)). In the SSR topology with headroom voltage control, thermal and power efficiency are increased, and system design costs and footprint are reduced.

Test results

SSR with headroom voltage control is tested in this report. With an **eight times smaller** buck inductor, the buck converter's temperature goes down by **22°C**, and efficiency with a system of 11 LEDs is improved by **more than 3 percent** from 86.1 to 89.4 percent.

A smaller inductor can help with the design of lighter and more compact devices. A bill of materials (BOM) cost reduction of **€0.50 to €0.90** can be expected.

The AC/DC controller: XDPL8219 and ICL8820

The [XDP™ family](#) offers high-performance digital power control AC-DC flyback controllers with a unique set of features for cost-effective, dual-stage LED drivers with SSR constant voltage output.

The [ICL88xx family](#) offers single-stage AC-DC flyback controller ICs for optimal price-performance ratio with excellent power factor, total harmonic distortion (THD), low EMI, and optimum efficiency at high light quality. Infineon's AC-DC constant-voltage LED controller ICs, such as ICL8800, include all the basic family features. The advanced ICL8810 and the fully-featured **ICL8820** include additional features to meet smart lighting requirements such as low stand-by power and jitter for emergency lighting.

Intended audience

The intended audience for this document are design engineers, technicians, and developers of electronic systems.

Table of contents

About this document.....	1
Table of contents.....	2
1 Introduction	3
2 Schematics and performance	7
2.1 LED current setpoint and precorrection.....	9
2.2 Measurement data	11
3 Appendix.....	13
References.....	16
Revision history.....	17
Disclaimer.....	18

1 Introduction

Two-stage topologies for dimmable LED drivers are becoming more popular than single-stage as they provide higher light quality over the entire dimming range and comply with class C of IEC 61000-3-2.

The primary stage with constant bus voltage provides power factor correction (PFC) for the entire system. The secondary stage supplies the LEDs with constant current across a wide dimming range. Bus voltage ripple is damped by 100 Hz/120 Hz.

The **ILD8150** provides a fast and accurate hysteretic algorithm requiring no feedback loop compensation. The switching frequency f_{sw} changes according to the formula:

$$f_{sw} = \frac{R_{CS}}{L(V_{CSH} - V_{CSL}) + R_{CS}V_{IN}t_{delay}} \cdot \frac{V_{OUT}(V_{IN} - V_{OUT})}{V_{IN}}$$

Equation 1

The switching frequency changes over the output voltage, as shown in **Figure 1** for an inductor of 860 μ H. With a 100- μ H inductor the effect would be much stronger. Typically, the output voltage of LED drivers varies by a factor of two – for example, 30 to 59 V in safety extra-low voltage (SELV) LED drivers. As shown in **Figure 1**, the switching frequency changes 1.5 times over the output voltage range, increasing switching losses significantly at lower voltage, causing higher power dissipation.

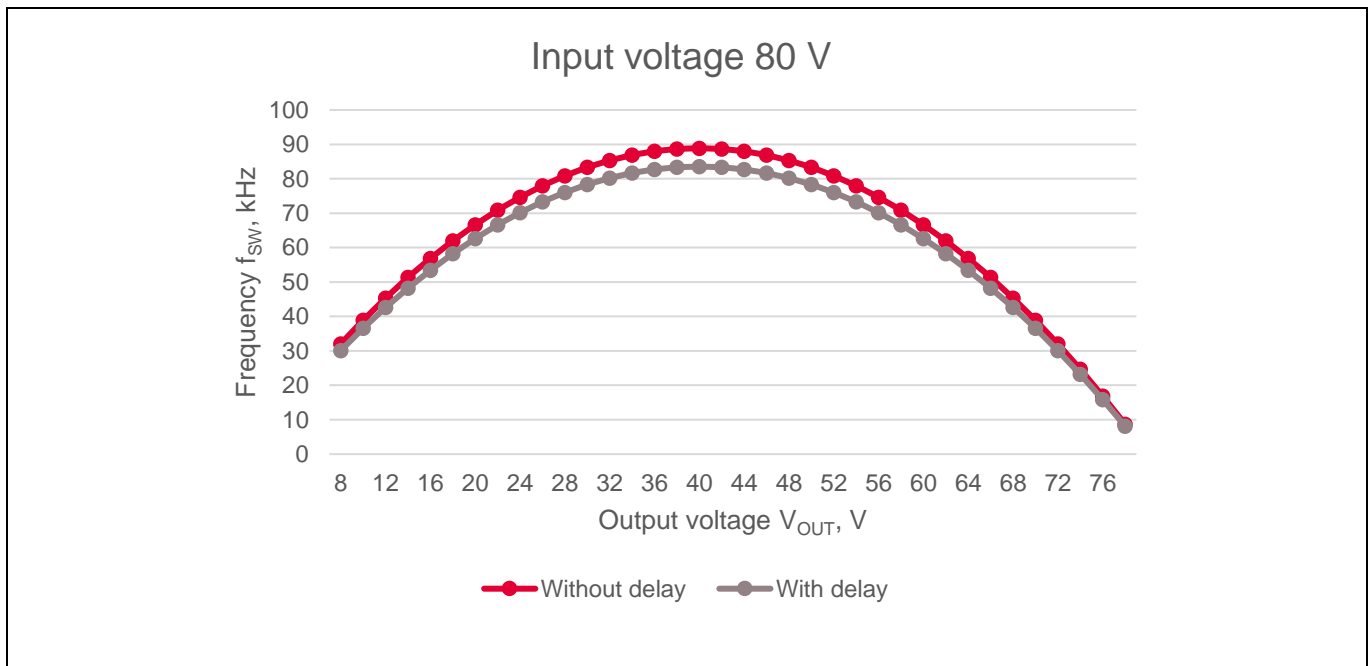

Figure 1 Switching frequency vs. output voltage in ILD8150(E)

Figure 2 shows reference designs [REF_ILD8150_DC_1.5A](#) (SP002798058) and [REF_ILD8150_DC_1.5A_SMD](#) (SP005351260). Parameters are compared for $V_{IN} = 70$ V, $V_{LED} = 51$ V, $I_{LED} = 1$ A with $L = 860$ μ H (80 kHz) and $L = 100$ μ H (460 kHz). The former can provide up to 1.5 A LED current; however, a large inductor is required. The latter can supply up to 800 mA with a much smaller inductor. Conduction losses are dominant in REF_ILD8150_DC_1.5A while switching losses are stronger in REF_ILD8150_DC_1.5A_SMD. Designers face a trade-off between switching frequency and power efficiency due to the limited power dissipation budget of the IC.

ILD8150E high-efficiency reference design REF_ILD8150E_HE

Headroom voltage control in high-efficiency two-stage LED drivers

Introduction

For high-frequency operation, designers should note two key considerations:

- Radiated EMI is becoming more noticeable. An additional output EMI filter might be needed.
- IC internal delays have a greater effect on regulation accuracy.

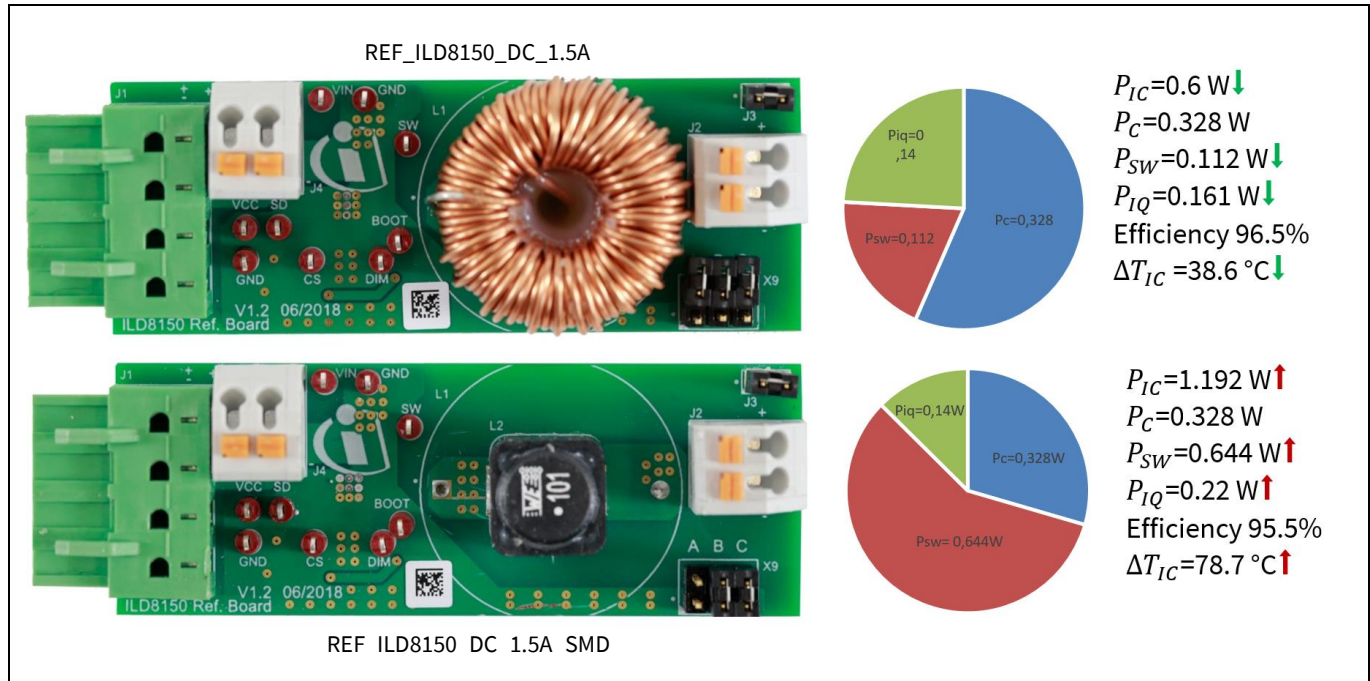

Figure 2 REF_ILD8150_DC_1.5A (SP002798058) and REF_ILD8150_DC_1.5A_SMD (SP005351260) comparison

The proposed design with headroom voltage control addresses the EMI and accuracy issues and helps minimize power dissipation, inductor size and frequency variation. Headroom voltage control is pictured in [Figure 3](#) and in the simplified circuit in [Figure 4](#).

The schematic of [Figure 3.a](#) shows the standard feedback loop with constant bus voltage V_{OUT} . The schematic of [Figure 3.b](#) shows the alternate block diagram with headroom voltage control.

In [Figure 3.b](#), the difference between bus voltage V_{OUT} and the headroom voltage V_{LED} , is regulated by the op-amp to match a pre-defined value of a few volts, ensuring proper operation of the buck converter and suppression of the bus voltage ripple.

Because the voltage difference $V_{OUT} - V_{LED}$ is kept constant with only a low-frequency ripple, the increase of the switching frequency with increasing LED voltage is drastically reduced, as shown in [Figure 5](#). [Figure 5](#) compares headroom voltage control with the standard feedback loop. The crossover frequency of the feedback is chosen in the range of a few Hertz (the same as for PFC) such that the resulting 100 Hz or 120 Hz ripple does not affect regulation.

ILD8150E high-efficiency reference design REF_ILD8150E_HE

Headroom voltage control in high-efficiency two-stage LED drivers

Introduction

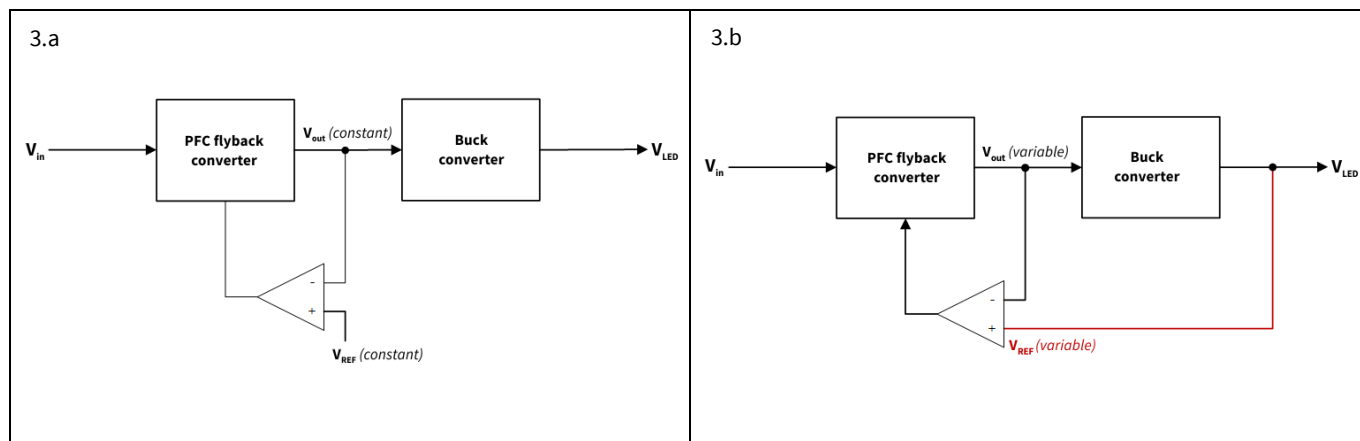

Figure 3 Block diagrams of two-stage topologies: 3.a standard on the left, 3.b headroom control on the right

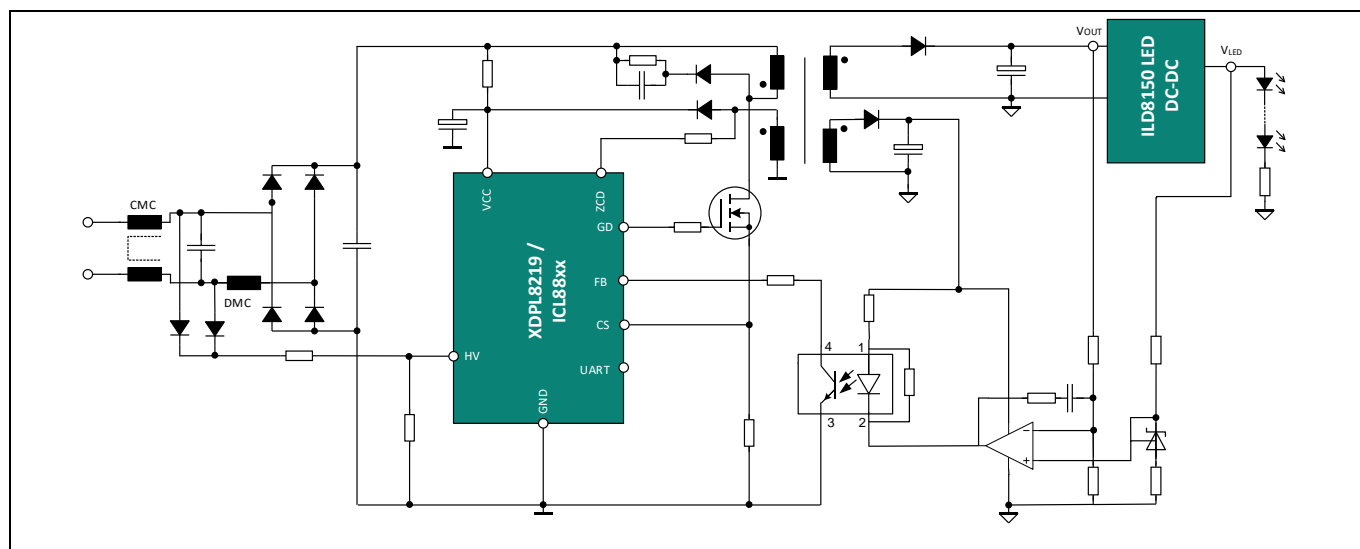

Figure 4 XDPL8219/ICL88xx + ILD8150 high-efficiency solution with headroom control – simplified schematic

Introduction

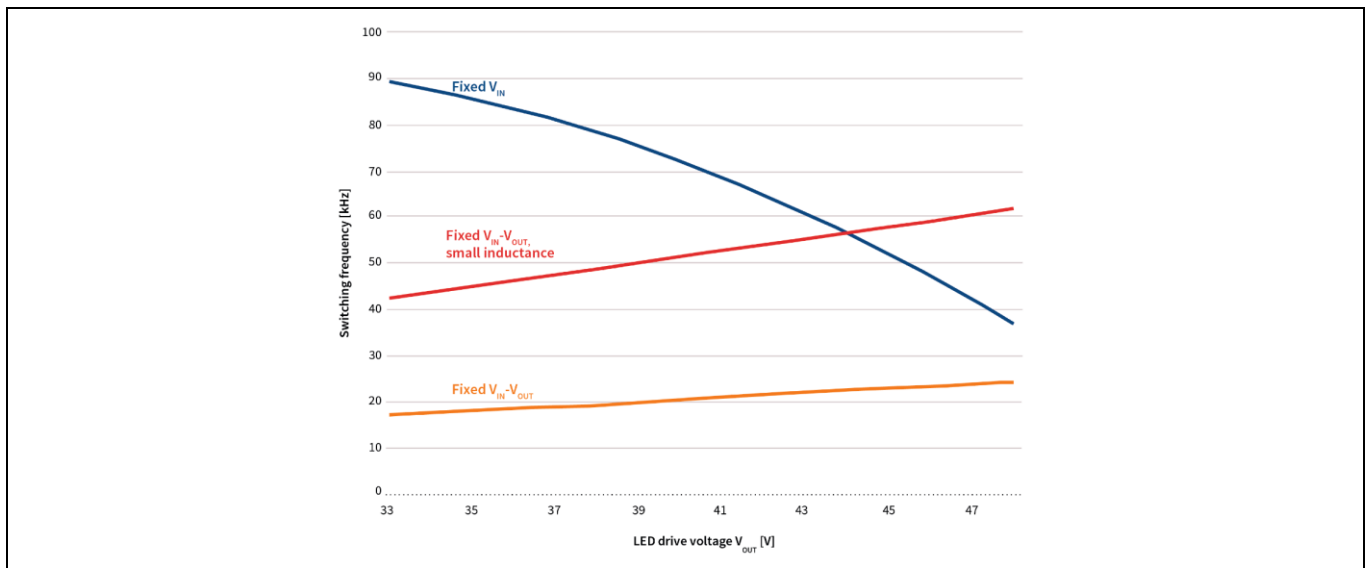

Figure 5 Frequency variation over LED voltage drop. Blue: standard feedback loop. Orange: headroom voltage control loop with large inductor (860 μH). Red: headroom voltage control loop with small inductor (100 μH)

A comparison of system efficiency for the standard feedback loop and for the headroom control loop is shown in Figure 11.

As you can see from Figure 5 and Figure 11, a 100- μH inductor is enough to operate at a reasonable switching frequency of 40 to 60 kHz with a significant efficiency increase.

Figure 13 shows a 22.2°C temperature drop for the ILD8150E with the headroom voltage control set to $V_{LED} = 33\text{ V}$, $I_{LED} = 1.5\text{ A}$ and $L = 100\ \mu\text{H}$.

Headroom control voltage in SSR topologies introduces various benefits. System efficiency is significantly improved. The IC temperature is drastically decreased. The maximum LED current capability is increased. The smaller inductor benefits the system design costs and the footprint. No additional components are needed.

ILD8150E high-efficiency reference design REF_ILD8150E_HE

Headroom voltage control in high-efficiency two-stage LED drivers

Schematics and performance

2 Schematics and performance

Table 1 Reference design specifications

Specification	Symbol	Value	Unit
Maximum DC input voltage	V DC	80	V DC
Maximum LED current	I_{LED_max}	1.5	A
LED voltage range	V_{LED}	30 ~ 59	V
Dimming range	Dim	0.5 to 100	%
Maximum efficiency	Eff_{max}	97	%

Standard compliance

Flicker	-	IEEE 1789	-
---------	---	-----------	---

Board dimensions

Size	L x W x H	Main board: 81 x 27 x 24	mm
------	-----------	--------------------------	----

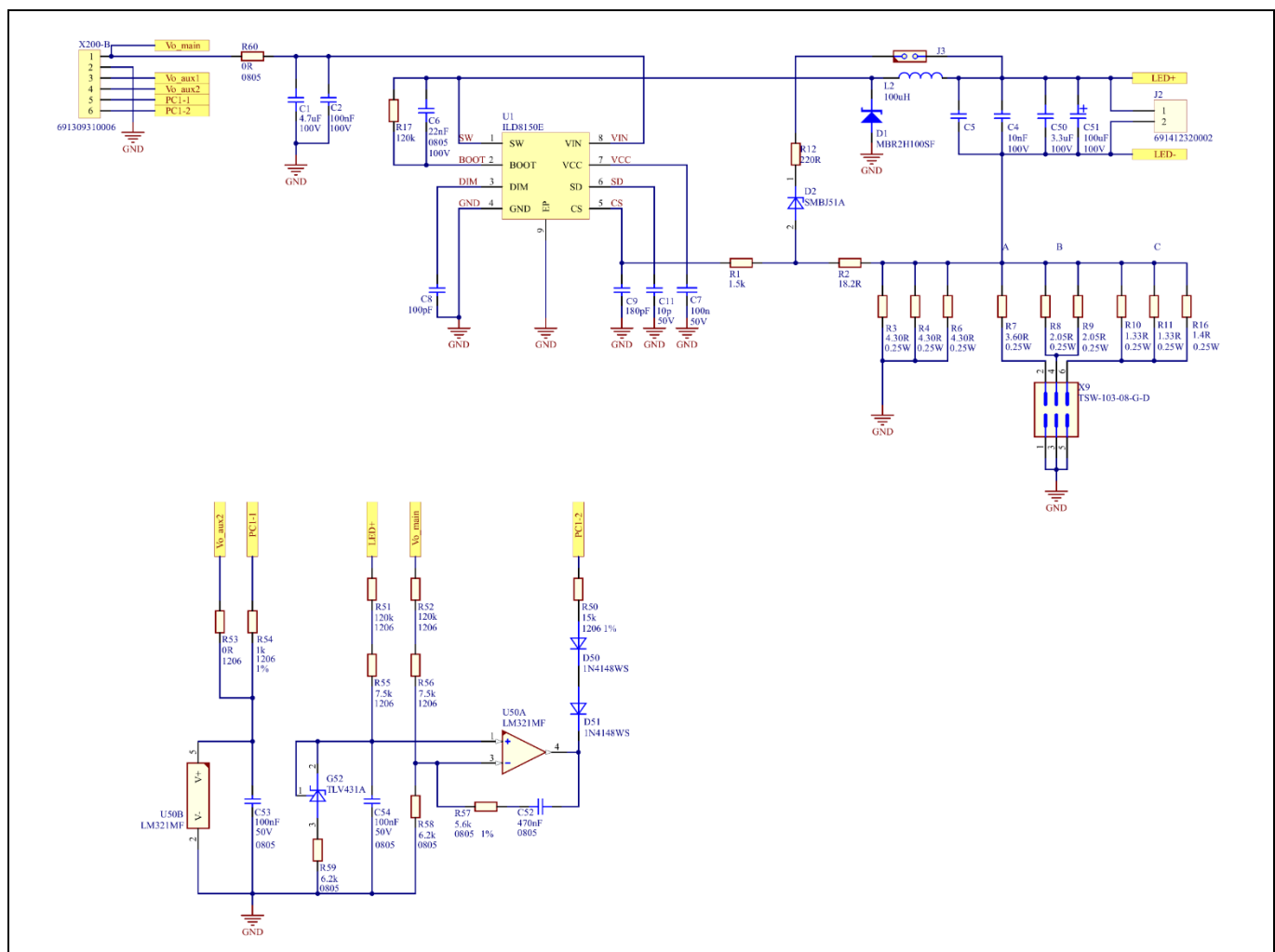

Figure 6 ILD8150_HE reference design circuit – ILD8150E LED buck controller with headroom control feedback loop

ILD8150E high-efficiency reference design REF_ILD8150E_HE

Headroom voltage control in high-efficiency two-stage LED drivers

Schematics and performance

The circuit is divided into two parts. The first is based on the ILD8150 LED buck converter. J3 is responsible for overvoltage protection. The second part includes the feedback amplifier based on U50. PC1-1 and PC1-2 are connected to the optocoupler. V_{o_aux2} is the voltage supply of 12 V, which comes from the primary stage. LED+ senses LED voltage, V_{o_main} senses the bus voltage. G52 is a reference voltage V_{Ref} . The headroom voltage is defined as:

$$V_{OUT} - V_{LED} = V_{Ref} \cdot \frac{R_{51} + R_{55}}{R_{59}}$$

Equation 2

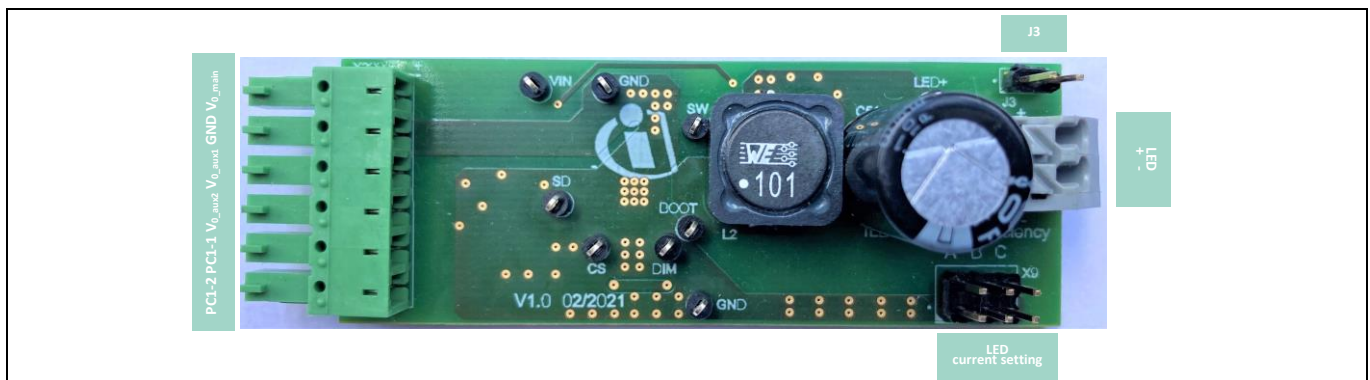

Figure 7 Reference design – dimensions 81 mm (L) x 27 mm (W) x 24 mm (H)

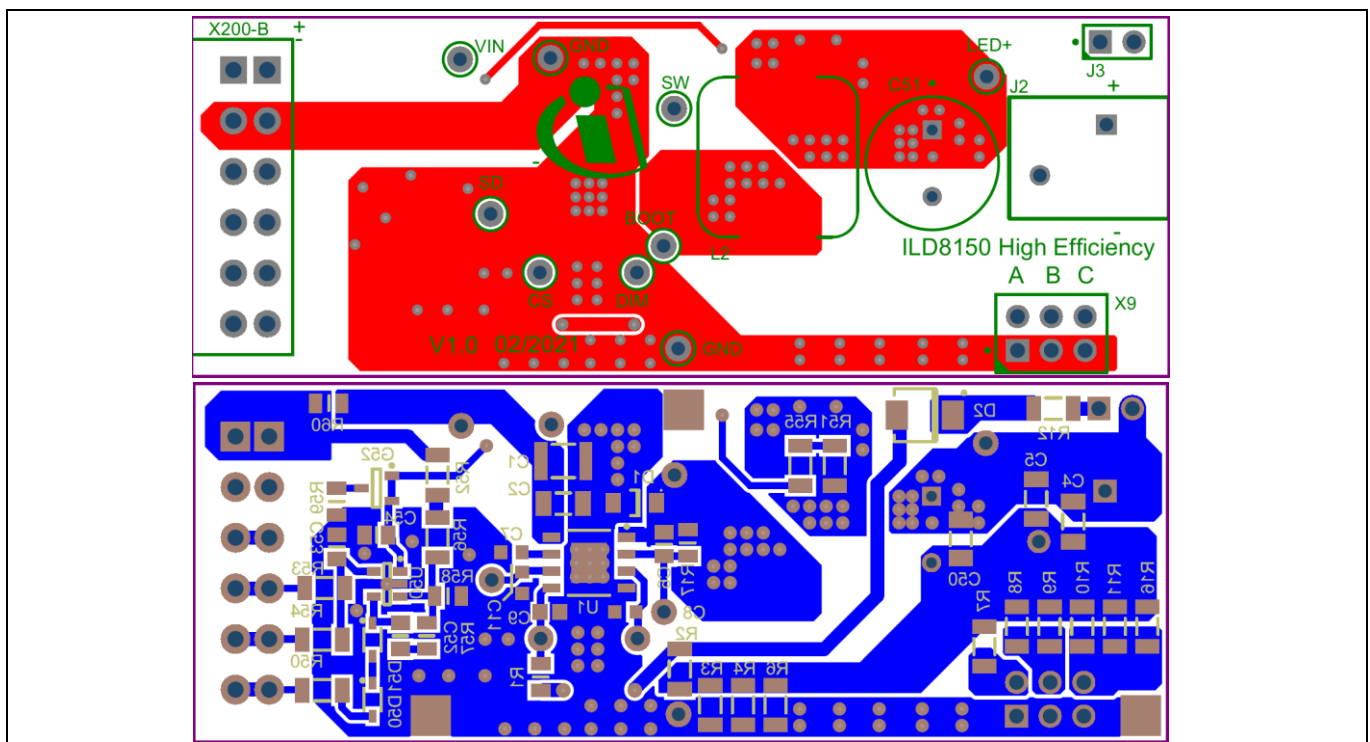

Figure 8 ILD8150E high-efficiency design PCB layout – top and bottom

Figure 9 shows the system primary stage with XDPL8219 and the ILD8150E_HE board. The ILD8150E_HE board can also be used together with the ICL8810 SSR reference design, but the feedback loop must be adjusted with components R57 and C52.

ILD8150E high-efficiency reference design REF_ILD8150E_HE

Headroom voltage control in high-efficiency two-stage LED drivers

Schematics and performance

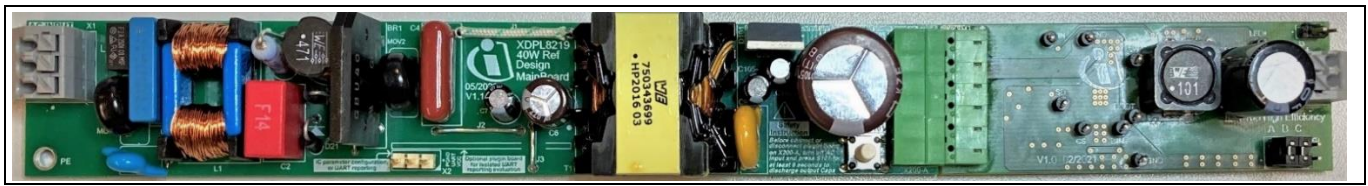

Figure 9 System XDP8219 reference design + ILD8150_HE board

2.1 LED current setpoint and precorrection

The LED current can be set via jumpers at connector X9. The board is configurable to have an output current in the range 250 to 1500 mA, with current adjustment by jumpers X9 A, B, and C as shown in [Table 2](#).

Table 2 LED current setting with different Jumper positions

Jumper X9A	Jumper X9B	Jumper X9C	Nominal output current (mA)
–	–	–	250
V	–	–	350
–	V	–	600
V	V	–	700
–	–	V	1050
V	–	V	1150
–	V	V	1400
V	V	V	1500

The LED current sees some regulation offset, which is related to the switching delay of the system and needs to be considered accordingly. This is most obvious for high duty cycles ($D > 0.8$) when the delay t_{delay} takes a significant part of the off-time t_{off} . As shown in [Figure 10](#), for a high duty cycle, the off-time t_{off} is relatively short, so the influence of the switching delay is very dominant. Therefore, the inductor current of the buck converter undershoots, which results in an LED current that is lower than the configured setting selected via connector X9.

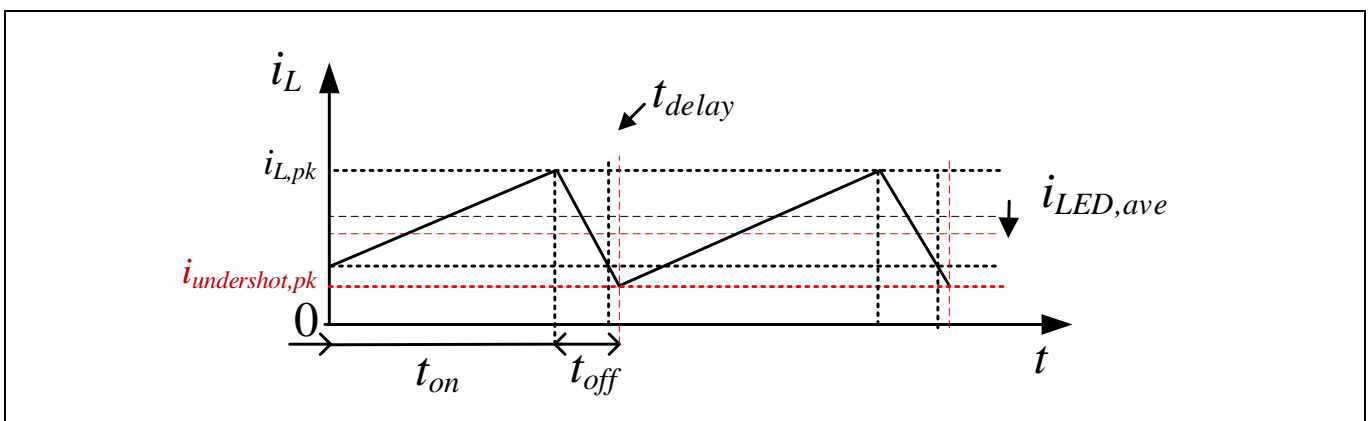

Figure 10 i_{LED} undershoot at high duty cycles

According to the datasheet of ILD8150E, the average LED current is determined by the formula:

$$I_{LED,AVG} = \frac{V_{CS,AVG}}{R_{CS}}$$

Equation 3

$$V_{CS,AVG} = \frac{(V_{CSH} + V_{CSL})}{2}$$

Equation 4

For the high duty cycle case, the lower current sense (CS) reference level V_{CSL} needs to be exchanged by a corrected reference level $V_{CSL'}$ that considers the influence of the switching delay for this condition:

$$V_{CS,AVG} = \frac{(V_{CSH} + V_{CSL'})}{2}$$

Equation 5

$$V_{CSL'} = V_{CSL} \left(1 - f_{SW} \frac{t_{delay}}{1-D}\right)$$

Equation 6

$$t_{delay} = 120ns + R_1 C_9$$

Equation 7

Where,

R_1 and C_9 = Filter components attached to the CS pin of the ILD8150E IC as shown in the schematic in [Figure 6](#).

f_{SW} = Switching frequency of the buck converter, while D is the duty cycle.

V_{CSH} and V_{CSL} = CS reference voltage levels (see the datasheet of ILD8150E).

R_{CS} = Value of the current sense resistors R3-R11 and R16. Depending on the jumper setting in connector X9, the equivalent resistance must be calculated from the values of the active resistors.

With this formula, the corrected LED current for high duty cycles can be calculated.

2.2 Measurement data

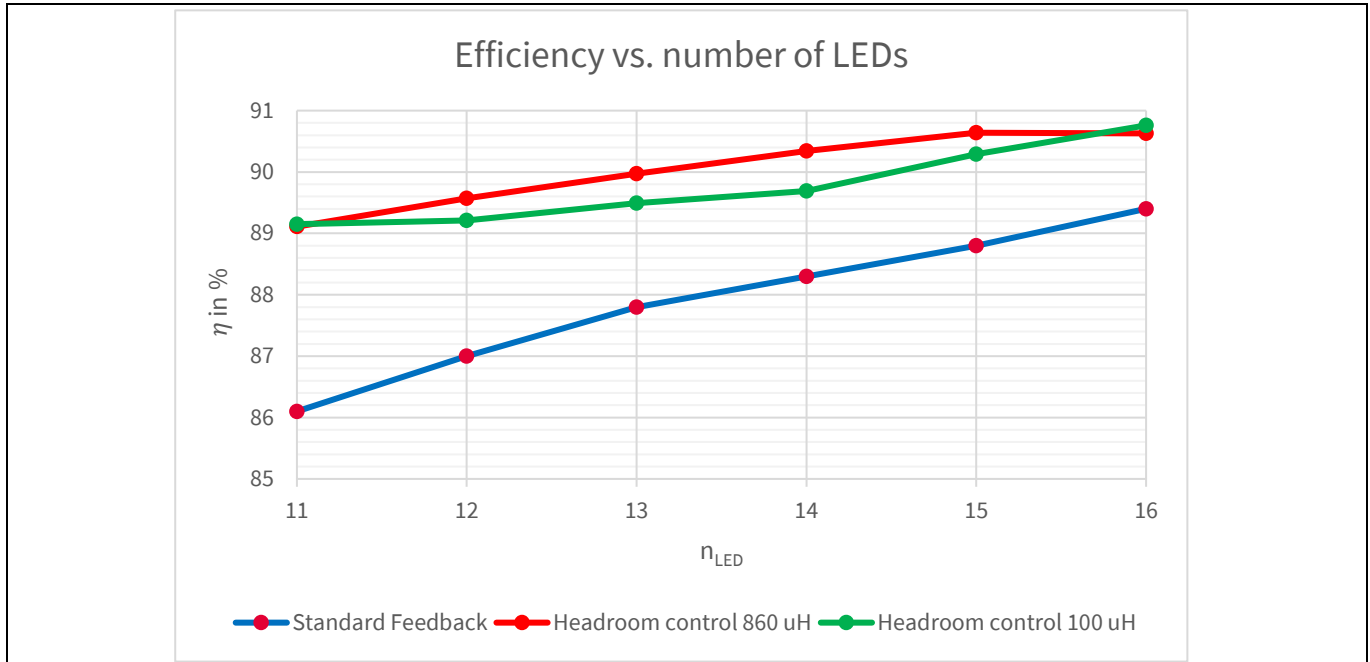

Figure 11 System efficiency - XDPL8219 reference design + ILD8150_HE. $V_{in} = 230\text{ V AC}$, $I_{LED} = 700\text{ mA}$, number of LEDs = 10 to 18

Figure 11 shows the system efficiency improvement. The boards with headroom voltage control and inductors of 100 μH and 860 μH are compared with the standard solution. The 100- μH inductor is already enough to achieve a good result – about **3 percent efficiency improvement to 89.4 percent efficiency** with the output of 11 LEDs and about 1.4 percent improvement with 16 LEDs.

The IC temperature drop is shown in Figure 14. The temperature drops by 22.2°C at an LED current of 1.5 A.

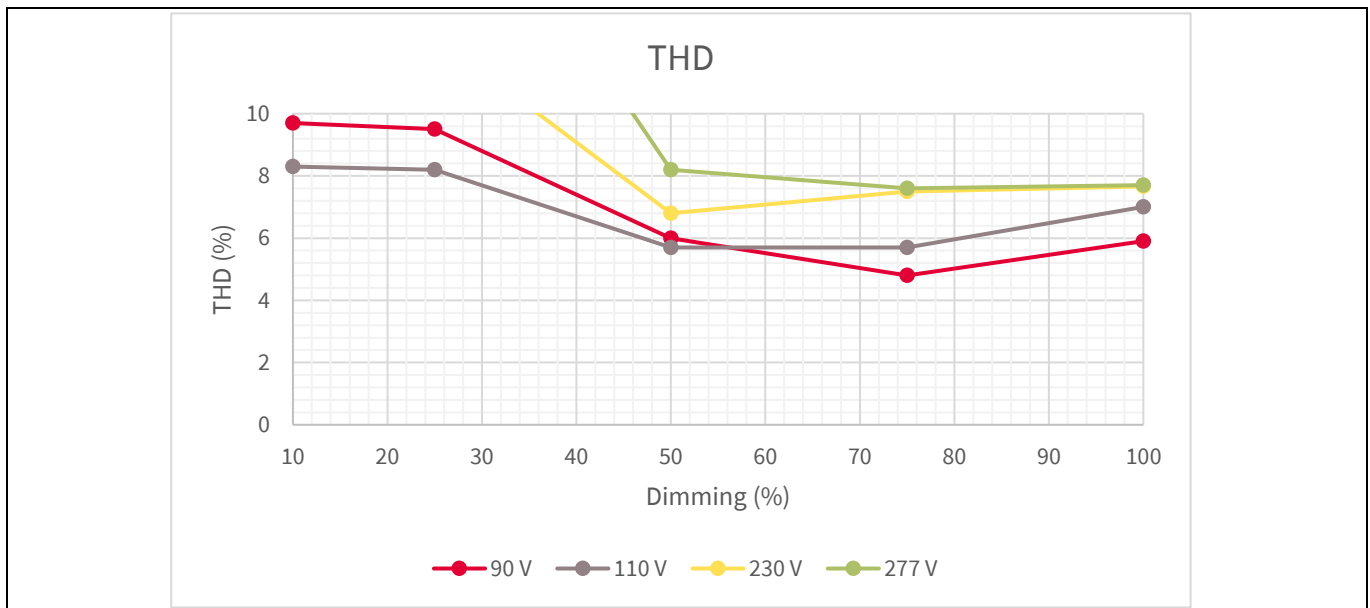

Figure 12 THD over dimming for different input voltages - maximum output power 43 W

ILD8150E high-efficiency reference design REF_ILD8150E_HE

Headroom voltage control in high-efficiency two-stage LED drivers

Schematics and performance

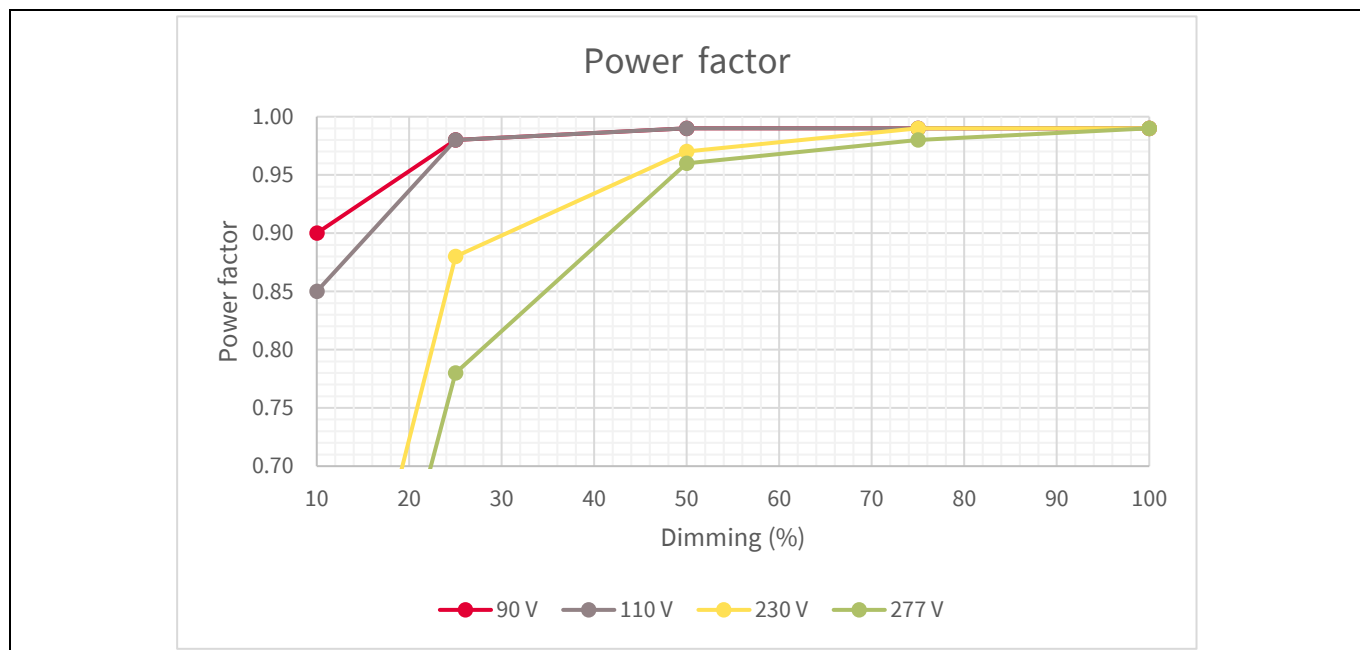

Figure 13 Power factor over dimming for different input voltages - maximum output power 43 W

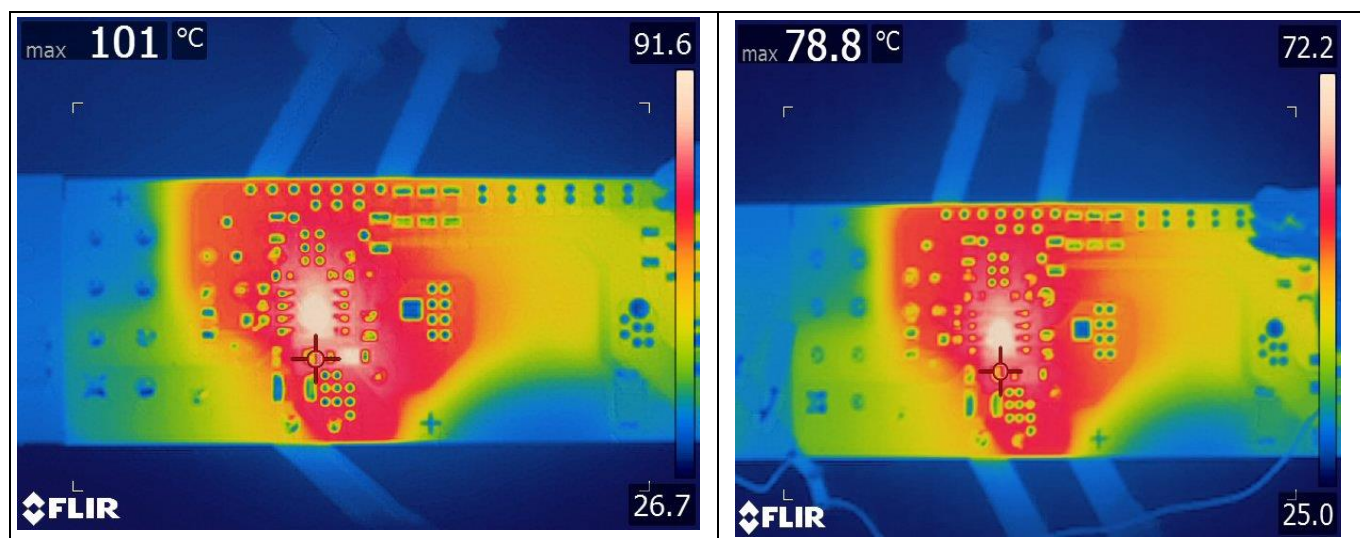

Figure 14 IC temperature with standard feedback loop and headroom control, $V_{LED} = 33\text{ V}$, $I_{LED} = 1.5\text{ A}$ with $L = 100\text{ }\mu\text{H}$

3 Appendix

Table 3 Bill of materials

#No.	Designator	Description	Manufacturer	Manufacturer part number
1	BOOT	5000/CON-THT-TP-5000	Keystone	5000
2	C1	Capacitor 4.7 μ F/100 V/1210/10%	TDK	C3225X7S2A475K200AB
3	C2	Capacitor 100 nF/100 V/1206/X7R/10%	TDK	C3216X7R2A104K160AA
4	C4	Capacitor 10 nF/100 V/1206/X7R/10%	AVX	12061C103K4Z2A
5	C6	Capacitor 22 nF/100 V/0805/X7R/5%	Murata	GRM21BR72A223JA01
6	C7	100 n/50 V/0603/X7R/10%	AVX	06035C104K4Z2A
7	C8	Capacitor 100 pF/CAPC1608X90N/C0G/5%	Kemet	C0603C0G1H101J030B A
8	C9	Capacitor 180 pF/0603/C0G/1%	Kemet	C0603C181J5GACTU
9	C11	10 p/50 V/CAPC1608X90N/C0G (EIA)/5%	Murata	GCM1885C1H100JA16#
10	C50	Capacitor 3.3 μ F/100 V/1206/20%	TDK	C3216X7S2A335M160A B
11	C51	Capacitor 100 μ F/100 V/radial type/20%	Panasonic	ECA-2AM101
12	C52	Capacitor 1.5 μ F/16 V/0805/X7R/10%	Murata	GCM21BR71C155KA37
13	C53	Capacitor 100 nF/50 V/ 0805/X7R/10%	Yageo	CC0805KRX7R9BB104
14	C54	Capacitor 100 nF/50 V/ 0805/X7R/10%	Yageo	CC0805KRX7R9BB104
15	CS	5000/CON-THT-TP-5000	Keystone	5000
16	D1	MBR2H100SF/100 V/SOD-123F	Onsemi	MBR2H100SFT3G
17	D2	Diode SMBJ51A/DO-214AA	Onsemi	SMBJ51A
18	D50	Diode 1N4148WS/75 V/SOD-323	Diodes Incorporated	1N4148WS-7-F
19	D51	Diode 1N4148WS/75 V/SOD-323	Diodes Incorporated	1N4148WS-7-F
20	DIM	5000/CON-THT-TP-5000	Keystone	5000
21	G52	Power TLV431A/SOT23-3 (DBZ)	Texas Instruments	TLV431AIDBZR
22	GND	5000/CON-THT-TP-5000	Keystone	5000
23	J2	691412320002	Würth Elektronik	691412320002
24	J3	HTSW-102-07-L-S/ HDRV2W64P254_1X2_496X248X838B	Samtec	HTSW-102-07-L-S
25	J3-J	Jumper, black	Samtec	SNT-100-BK-T

Appendix

#No.	Designator	Description	Manufacturer	Manufacturer part number
26	L2	100 µH/WE-PD_1210_metal base	Würth Elektronik	7447709101 alt. 784770101
27	LED+	5000/CON-THT-TP-5000	Keystone	5000
28	R1	1.5k/150 V/0805/1%	Vishay	CRCW08051K50FKEA
29	R2	18.2 R/200 V/1206/1%	Vishay	CRCW120618R2FKEA
30	R3	Resistor 4.30 R/1206/1%	Vishay	CRCW12064R30FK
31	R4	Resistor 4.30 R/1206/1%	Vishay	CRCW12064R30FK
32	R6	Resistor 4.30 R/1206/1%	Vishay	CRCW12064R30FK
33	R7	Resistor 3.60 R/1206/1%	Vishay	CRCW12063R60FK
34	R8	Resistor 2.05 R/1206/1%	Vishay	CRCW12062R05FK
35	R9	Resistor 2.05 R/1206/1%	Vishay	CRCW12062R05FK
36	R10	Resistor 1.33 R/1206/1%	Vishay	CRCW12061R33FK
37	R11	Resistor 1.33 R/1206/1%	Vishay	CRCW12061R33FK
38	R12	Resistor 220 R/1206/1%	Vishay	CRCW1206220RFK
39	R16	1.4 R/200 V/1206/1%	Vishay	CRCW12061R40FKEA
40	R17	Resistor 120k/150 V/0805/1%	Vishay	CRCW0805120KFK
41	R50	Resistor 15k/200 V/1206/1%	Vishay	CRCW120615K0FK
42	R51	Resistor 36k/200 V/1206/1%	Vishay	CRCW120636K0FK
43	R52	Resistor 36k/200 V/1206/1%	Vishay	CRCW120636K0FK
44	R53	Resistor 0 R/200 V/1206/0R	Vishay	CRCW12060000Z0
45	R54	Resistor 1k/200 V/1206/1%	Vishay	CRCW12061K00FK
46	R55	Resistor 7.5k/200 V/1206/1%	Vishay	CRCW12067K50FK
47	R56	Resistor 7.5k/200 V/1206/1%	Vishay	CRCW12067K50FK
48	R57	Resistor 22k/150 V/0805/1%	Vishay	CRCW080522K0FK
49	R58	Resistor 6.2k/150 V/0805/1%	Vishay	CRCW08056K20FK
50	R59	Resistor 6.2k/150 V/0805/1%	Vishay	CRCW08056K20FK
51	R60	Resistor 0 R/150 V/0805/0R	Vishay	CRCW08050000Z0
52	SD	5000/CON-THT-TP-5000	Keystone	5000
53	SW	5000/CON-THT-TP-5000	Keystone	5000
54	U1	ILD8150E/SOP8	Infineon	ILD8150E
55	U50	Analog LM321MF/SOT-23-5	Texas Instruments	LM321MF
56	VIN	5000/CON-THT-TP-5000	Keystone	5000
57	X5	5000/CON-THT-TP-5000	Keystone	5000
58	X9	TSW-103-08-G-D/ HDRV6W64P254_3X2_508X762X838B	Samtec	TSW-103-08-G-D
59	X9-J	Jumper, black 3x	Samtec	SNT-100-BK-T
60	X200-B	Terminal block/6 pins/3.81 mm pitch/3.81*6 – duplicate – duplicate	Würth Elektronik	691309310006

Appendix

#No.	Designator	Description	Manufacturer	Manufacturer part number
61	C5	Capacitor NA/100 V/1206/X7R/10%	AVX	12061C103K4Z2A

References

- [1] Infineon Technologies AG: *ILD8150/ILD8150E datasheet*; [Available online](#)
- [2] Infineon Technologies AG: *ILD8150/E 80 V high side buck LED driver IC with hybrid dimming*; [Available online](#)
- [3] Infineon Technologies AG: *ILD8150 high-frequency operation*; [Available online](#)
- [4] Infineon Technologies AG: *ILD8150 in tunable white and multichannel LED applications*; [Available online](#)

Revision history

Revision history

Document revision	Date	Description of changes
V 1.0	2021-09-07	First release
V 2.0	2022-12-20	Content revision
V 2.1	2023-11-17	Add LED current vs. Jumper positions table
V 2.2	2024-01-16	Add LED current precorrection section

Trademarks

All referenced product or service names and trademarks are the property of their respective owners.

Edition 2024-01-16

Published by

Infineon Technologies AG

81726 Munich, Germany

© 2024 Infineon Technologies AG.

All Rights Reserved.

Do you have a question about this document?

Email: erratum@infineon.com

Document reference

ER_2104_PL39_2105_090928

Important notice

The information contained in this application note is given as a hint for the implementation of the product only and shall in no event be regarded as a description or warranty of a certain functionality, condition or quality of the product. Before implementation of the product, the recipient of this application note must verify any function and other technical information given herein in the real application. Infineon Technologies hereby disclaims any and all warranties and liabilities of any kind (including without limitation warranties of non-infringement of intellectual property rights of any third party) with respect to any and all information given in this application note.

The data contained in this document is exclusively intended for technically trained staff. It is the responsibility of customer's technical departments to evaluate the suitability of the product for the intended application and the completeness of the product information given in this document with respect to such application.

Warnings

Due to technical requirements products may contain dangerous substances. For information on the types in question please contact your nearest Infineon Technologies office.

Except as otherwise explicitly approved by Infineon Technologies in a written document signed by authorized representatives of Infineon Technologies, Infineon Technologies' products may not be used in any applications where a failure of the product or any consequences of the use thereof can reasonably be expected to result in personal injury.