

# C4DE, Low Inductance, 400 – 1,000 VDC, for DC Link

## Overview

The C4DE capacitor is a polypropylene metallized film capacitor with a cylindrical, plastic box-type design filled with resin, and uses screw terminals.

## Applications

Typical applications include DC filtering and energy storage.

## Benefits

- Self-healing
- Low loss
- High ripple current
- High capacitance density
- Low inductance



## Part Number System

C4DE	F	P	Q	6175	A8T	K
Series	Rated Voltage (VDC)	Case & Fixing Bolt Code	Terminal Style	Capacitance Code (pF)	Internal Code	Tolerance
C4DE = MKP, DC Link Application	F = 400 H = 600 I = 800 N = 1,000	P = Cylindrical plastic case with fixing feet	Q = M8 threaded inserts	Digits two – four indicate the first three digits of the capacitance value. First digit indicates the number of zeros to be added.	A8T = Standard	K = 10%

## Dimensions – Millimeters

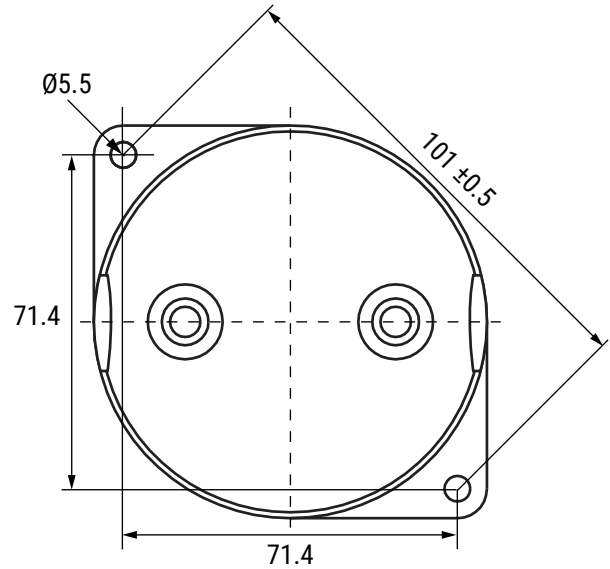
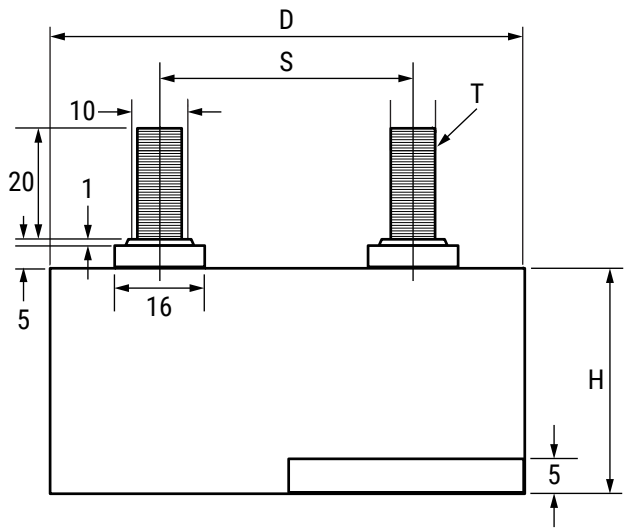

D	H	S	Terminations (T)
±0.5	±1	±1	
84	40	45	M8 x 20
84	51	45	M8 x 20
84	64	45	M8 x 20

## Qualifications

Reference Standards	IEC 61071, EN 61071
---------------------	---------------------

## Performance Characteristics

IEC Climatic Category	40/85/56
Temperature Range	-40°C to +85°C
Capacitance Tolerance	±10%
Capacitance Deviation in the Operating Temperature Range of -40°C to +85°C	±1.5% max on capacitance value measured at +20 °C
Test Voltage Terminal to Terminal ( $V_{TT}$ )	1.5 $V_n$ for 10 seconds at +25°C
Test Voltage Terminal to Case ( $V_{TC}$ )	3 kV – 50 Hz for 2 seconds
Derated Voltage and Lifetime Expectancy	1.2 x $V_n$ at +85°C = 1,000 hours
	1 x $V_n$ at +85°C = 10,000 hours
	0.9 x $V_n$ at +85°C = 100,000 hours
Derated Temperature and Lifetime expectancy	For working temperature between +85°C and +70°C, an increasing factor of 0.67 on the rated lifetime must be applied
Installation	Any position

## Environmental Compliance

As a leading global supplier of electronic components and an environmentally conscious company, KEMET continually aspires to improve the environmental effects of our manufacturing processes and our finished electronic components.

In Europe (RoHS Directive) and in some other geographical areas such as China (China RoHS), legislation has been enacted to prevent or otherwise limit the use of certain hazardous materials, including lead (Pb), in electronic equipment. KEMET monitors legislation globally to ensure compliance and endeavors to adjust our manufacturing processes and/or electronic components as may be required by applicable law.

For military, medical, automotive, and some commercial applications, the use of lead (Pb) in the termination is necessary and/or required by design. KEMET is committed to communicating RoHS compliance to our customers. Information related to RoHS compliance will be provided in data sheets and using specific identifiers on the packaging labels.

All KEMET power film capacitors are RoHS compliant.

**Table 1 – Ratings & Part Number Reference**

Cap Value (µF)	VDC	Maximum Dimensions (mm)		Ripple Current				Peak Current (A)	ESR (Max) 100 kHz (mΩ)	ESL (nH)	dV/dt (V/µs)	Packaging Quantity	Part Number
		D	L	10 kHz 25°C (A)	10 kHz 45°C (A)	10 kHz 65°C (A)	10 kHz 85°C (A)						
175	400	84	40	100	100	80	46	4,375	0.5	25	25	12	C4DEFPQ6175A8TK
260	400	84	51	100	100	77	45	5,200	0.62	32	20	12	C4DEFPQ6260A8TK
380	400	84	64	100	94	73	42	5,700	0.81	40	15	12	C4DEFPQ6380A8TK
100	600	84	40	100	93	72	42	3,000	0.6	25	30	12	C4DEHPQ6100A8TK
150	600	84	51	100	90	70	40	3,750	0.75	32	25	12	C4DEHPQ6150A8TK
220	600	84	64	100	85	65	38	4,400	1	40	20	12	C4DEHPQ6220A8TK
68	800	84	40	100	87	68	40	2,380	0.7	25	35	12	C4DEIPQ5680A8TK
100	800	84	51	100	84	65	37	3,000	0.9	32	30	12	C4DEIPQ6100A8TK
140	800	84	64	91	77	60	35	3,500	1.2	40	25	12	C4DEIPQ6140A8TK
47	1,000	84	40	96	81	63	36	1,739	0.8	25	37	12	C4DENPQ5470A8TK
68	1,000	84	51	92	77	60	35	2,176	1.1	32	32	12	C4DENPQ5680A8TK
100	1,000	84	64	86	72	56	32	2,700	1.3	40	27	12	C4DENPQ6100A8TK
Capacitance Value (µF)	VDC	D (mm)	L (mm)	Ripple Current				Peak Current	ESR	ESL	dV/dt (V/µs)	Packaging Quantity	Part Number

## Materials & Environment

The selection of raw materials that KEMET uses for the production of its electronic components is the result of extensive experience. KEMET directs specific attention toward environmental protection. KEMET selects its suppliers according to ISO 9001 standards and performs statistical analyses on raw materials before acceptance for use in manufacturing our electronic components. All materials are, to the best of KEMET’s knowledge, non-toxic and free from cadmium; mercury; chrome and compounds; polychlorine triphenyl (PCB); bromide and chlorinedioxins bromurate clorurate; CFC and HCFC; and asbestos.

## Dissipation Factor

Dissipation factor is a complex function involved with capacitor inefficiency. The  $\tan\delta$  may vary up and down with increased temperature. For more information, refer to Performance Characteristics.

## Sealing

### Hermetically Sealed Capacitors

As the temperature increases, the pressure inside the capacitor increases. If the internal pressure is high enough, it can cause a breach in the capacitor. Such a breach can result in leakage, impregnation, filling fluid, or moisture susceptibility.

### Barometric Pressure

The altitude at which hermetically sealed capacitors are operated controls the capacitor's voltage rating. As the barometric pressure decreases, the susceptibility to terminal arc-over increases. Non-hermetic capacitors can be affected by internal stresses due to pressure changes. These effects can be in the form of capacitance changes, dielectric arc-over, and/or low insulation resistance. Altitude can also affect heat transfer. Heat that is generated in an operation cannot be dissipated properly, and high  $RI^2$  losses and eventual failure can result.

## Construction

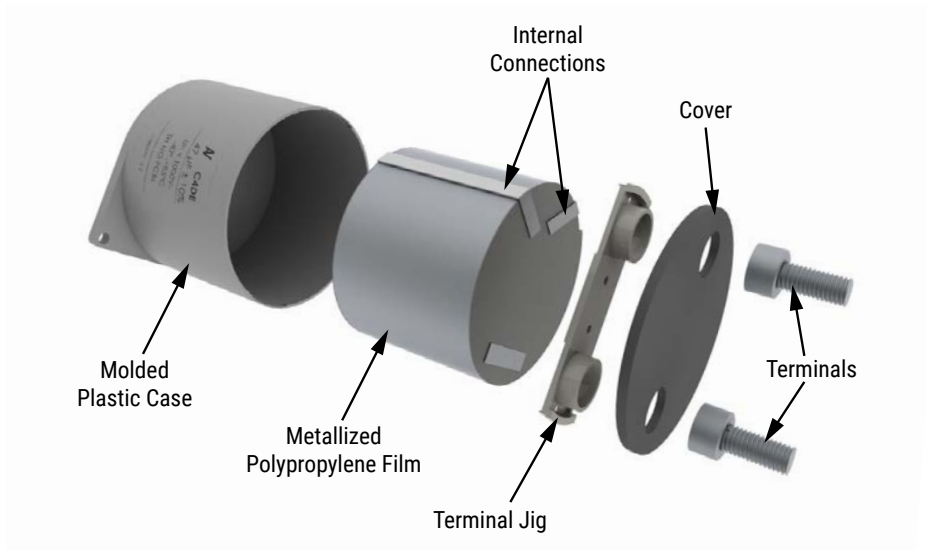

## Winding Scheme

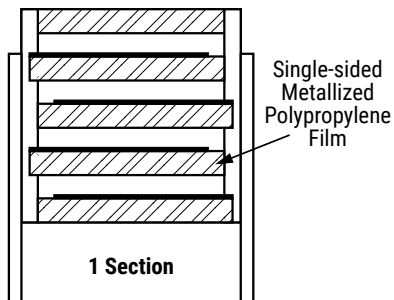

## Marking

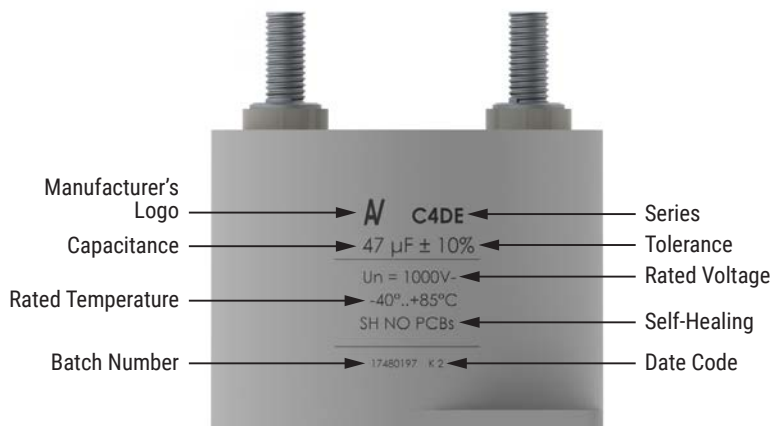

## KEMET Electronics Corporation Sales Offices

For a complete list of our global sales offices, please visit [www.kemet.com/sales](http://www.kemet.com/sales).

---

### Disclaimer

All product specifications, statements, information and data (collectively, the "Information") in this datasheet are subject to change. The customer is responsible for checking and verifying the extent to which the Information contained in this publication is applicable to an order at the time the order is placed. All Information given herein is believed to be accurate and reliable, but it is presented without guarantee, warranty, or responsibility of any kind, expressed or implied.

Statements of suitability for certain applications are based on KEMET Electronics Corporation's ("KEMET") knowledge of typical operating conditions for such applications, but are not intended to constitute – and KEMET specifically disclaims – any warranty concerning suitability for a specific customer application or use. The Information is intended for use only by customers who have the requisite experience and capability to determine the correct products for their application. Any technical advice inferred from this Information or otherwise provided by KEMET with reference to the use of KEMET's products is given gratis, and KEMET assumes no obligation or liability for the advice given or results obtained.

Although KEMET designs and manufactures its products to the most stringent quality and safety standards, given the current state of the art, isolated component failures may still occur. Accordingly, customer applications which require a high degree of reliability or safety should employ suitable designs or other safeguards (such as installation of protective circuitry or redundancies) in order to ensure that the failure of an electrical component does not result in a risk of personal injury or property damage.

Although all product-related warnings, cautions and notes must be observed, the customer should not assume that all safety measures are indicated or that other measures may not be required.

*KEMET is a registered trademark of KEMET Electronics Corporation.*