

Window lift DC board driver based on the L99H92 gate driver and an external MCU

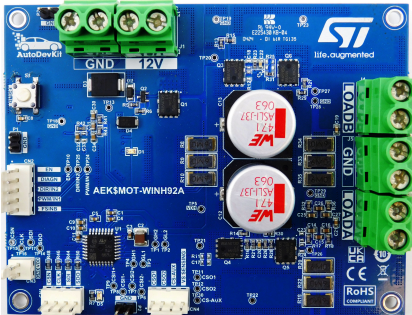

Features

- Up to 50 A motor drive
- Anti-pinch detection facilitated through programmable gain current sensing
- In-line, low-side, and high-side current sensing options
- Diagnostic pin to alert the microcontroller in case of faults, avoiding cyclic on-demand failure check via SPI thus ensuring a prompt intervention
- Reverse battery protection dedicated circuit
- Fault detection capabilities:
 - Open-load, short-to-ground, and short-to-battery conditions
 - Thermal warning and overtemperature shutdown
 - Under/overvoltage protections
 - Overcurrent protection
- Low component count
- Hosts the [L99H92](#) H-bridge gate driver for DC automotive applications
- Compact size: 103 mm x 80 mm
- Included in the [AutoDevkit](#) ecosystem

Description

The [AEK-MOT-WINH92](#) evaluation board key objective is to drive a DC motor for car window lifters, ensuring high safety levels.

This board perfectly fits in the automotive market trend, which goes towards the evolution of the window lift application, offering a new anti-pinch mechanism without leveraging on motor encoders but exploiting the board three different types of current sensing (in-line, low-side and high-side).

The board can be configured to work with a single H-bridge for a bidirectional DC motor or two independent half-bridges for two unidirectional DC motors.

Thanks to its compact size, the board can be connected to any microcontroller easily, exploiting separate and dedicated connectors for SPI communication, current sensing, and basic motor commands interface with fault detection capabilities. Another key feature is the adjustable gain for anti-pinch and for fulfilling any of the car window operative conditions (the current range levels could change when opening the window with adverse weather conditions, for example in case of ice).

The board also offers three diagnostic features to detect potential short-to-ground, short-to-battery, and open load conditions when the device is in the off state.

In case of failures, the DIAG pin alerts the external MCU, ensuring a prompt intervention in case of open-load, short-to-ground, and short-to-battery, thermal warning and overtemperature shutdown, under/overvoltage and overcurrent protection. For system debugging during the development phase, a fail-safe button was added to the board layout.

To allow the board robust protection and prevent damage due to the inversion of the power supply polarity, reverse polarity protection has been implemented.

Four external MOSFETs allow current flowing up to 50 A, in line with the board power dissipation capabilities.

Product summary	
Window lift DC board driver based on the L99H92 gate driver and an external MCU	AEK-MOT-WINH92
H-Bridge Gate Driver for Automotive Applications	L99H92
Applications	Window lifts Sun-roofs DC motor control

The board design is based on the [L99H92](#) H-bridge gate driver for automotive applications, which features flexible current sensing to offer different tools for advanced anti-pinching algorithm development. For systems requiring a higher safety level, you can enable a watchdog with configurable time window.

The [AutoDevkit](#) ecosystem offers a wide range of demos and drivers for the SPC58 microcontroller to facilitate your application design by rapidly jumping to the board usage:

- 1) The [SPC582Bxx_RLA - AEK_MOT_WINH92 Test application for discovery](#), to be downloaded on the SPC582B hosted on the [AEK-MCU-C1MLIT1](#) MCU board;
- 2) The [SPC584Bxx_RLA - AEK_MOT_WINH92 Test application for discovery](#), to be downloaded on the SPC584B hosted on the [SPC584B-DIS](#) discovery board;
- 3) The [SPC58ECxx_RLA - AEK_MOT_WINH92 Full Bridge Test application](#), to be downloaded on the SPC58EC hosted on the [AEK-MCU-C4MLIT1](#) MCU board;
- 4) The [SPC58ECxx_RLA - AEK_MOT_WINH92 Dual Half Bridge Test application](#), to be downloaded on the SPC58EC hosted on the [AEK-MCU-C4MLIT1](#) MCU board;
- 5) The [SPC58xNxx_RLA - AEK_MOT_WINH92 Test application for discovery](#), available in AutoDevKit Studio for reference;
- 6) The [SPC58ECxx_RLA - AEK_MOT_WINH92 Window Lift Test application](#), to be downloaded on the SPC58EC hosted on the [AEK-MCU-C4MLIT1](#) MCU board.

The first five demos show how to configure the [AEK-MOT-WINH92](#) to drive one bidirectional (full bridge configuration) or two unidirectional (half-bridge configuration, for example for oil and water pumps) DC motors, varying a PWM duty cycle signal.

The last demo shows how to configure the [AEK-MOT-WINH92](#) for window lift applications.

1 Block diagrams

Figure 1. Full-bridge functional block diagram

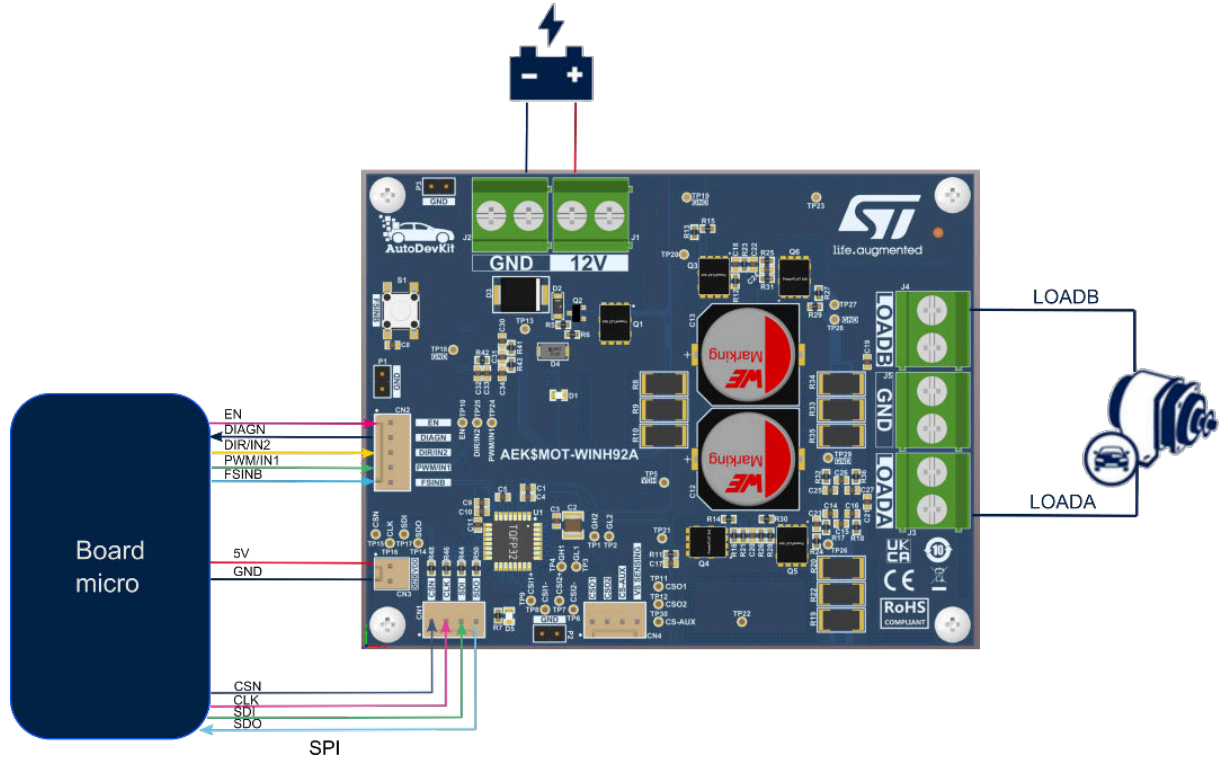

Figure 2. Dual half-bridge functional block diagram

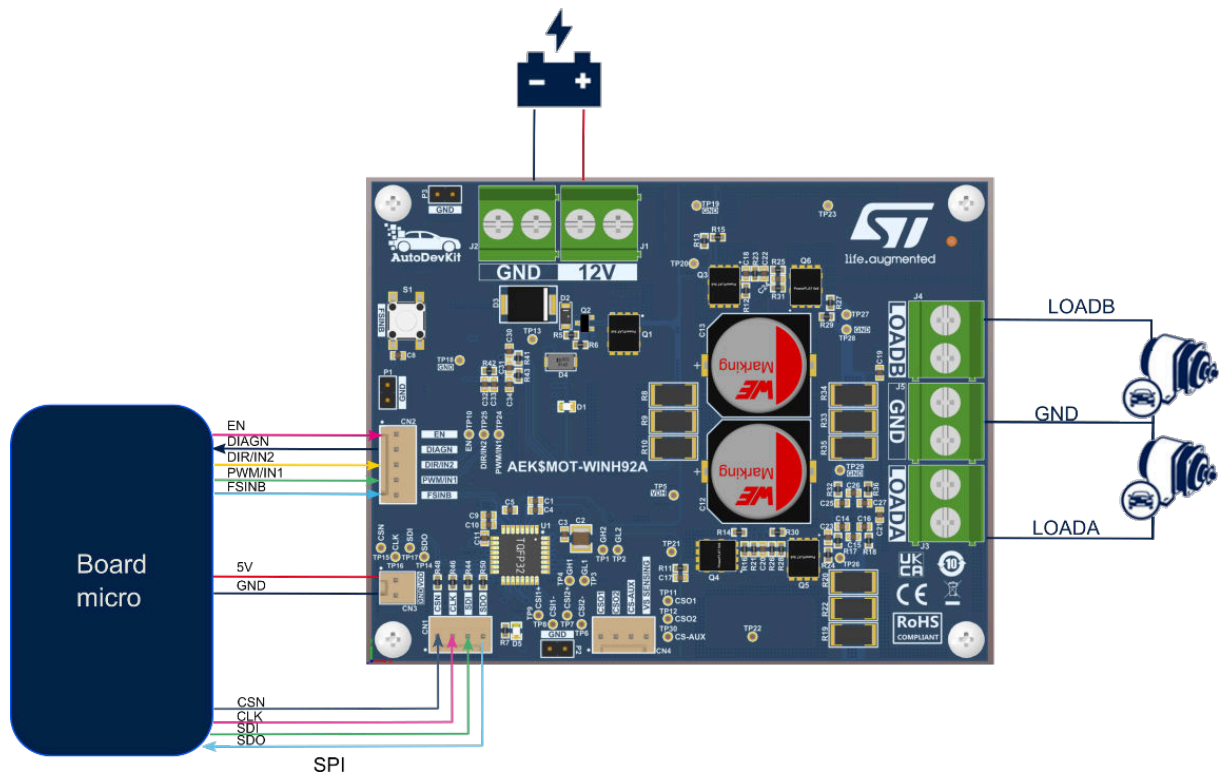
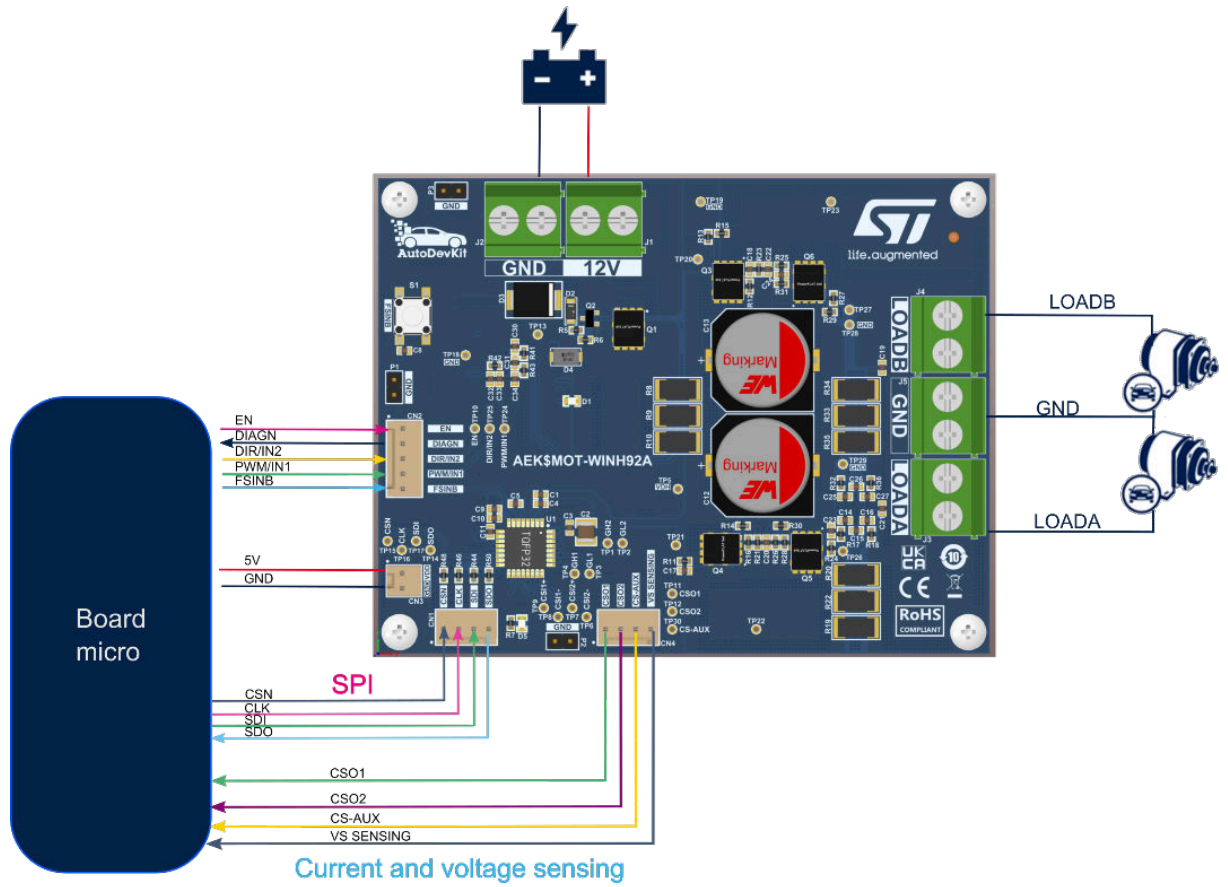

Figure 3. Dual half-bridge functional block diagram with current sensing



2 Schematic diagrams

Figure 4. AEK-MOT-WINH92 circuit schematic (1 of 4)

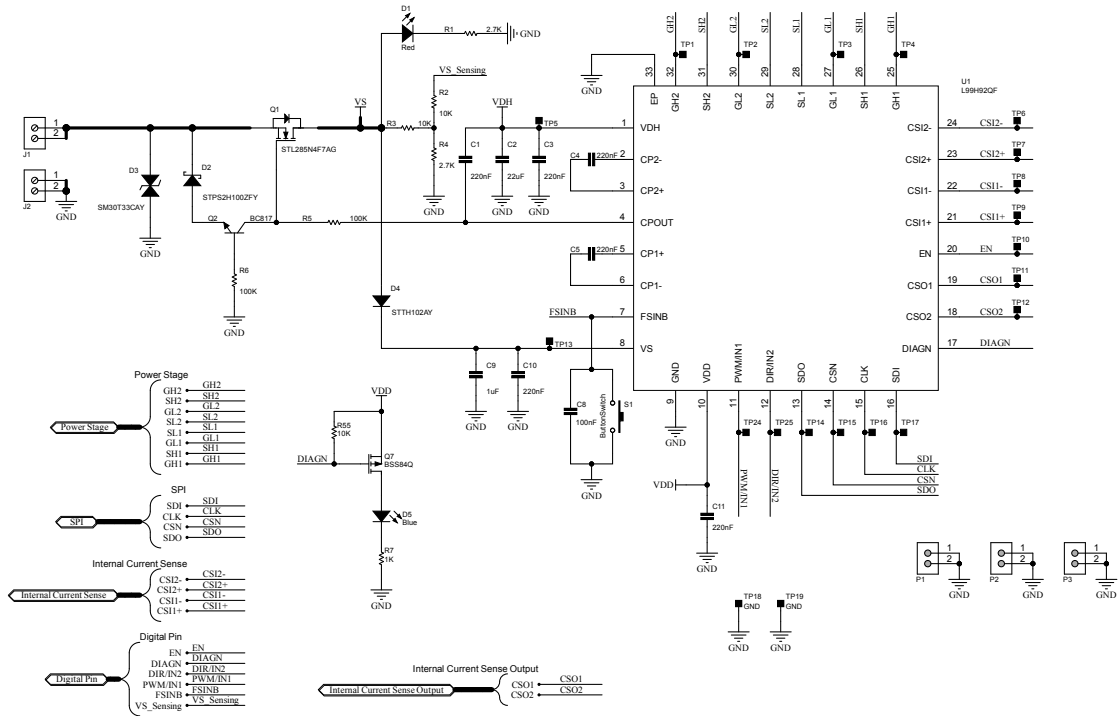

Figure 5. AEK-MOT-WINH92 circuit schematic (2 of 4)

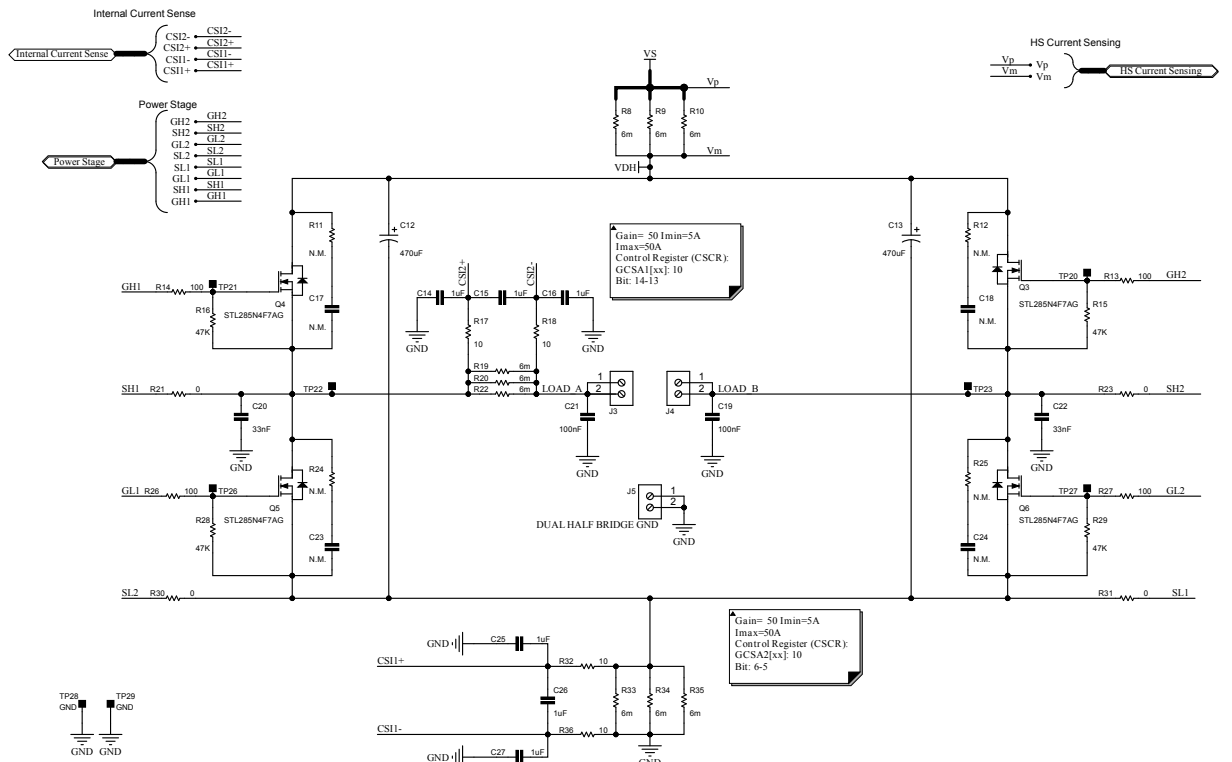

Figure 6. AEK-MOT-WINH92 circuit schematic (3 of 4)

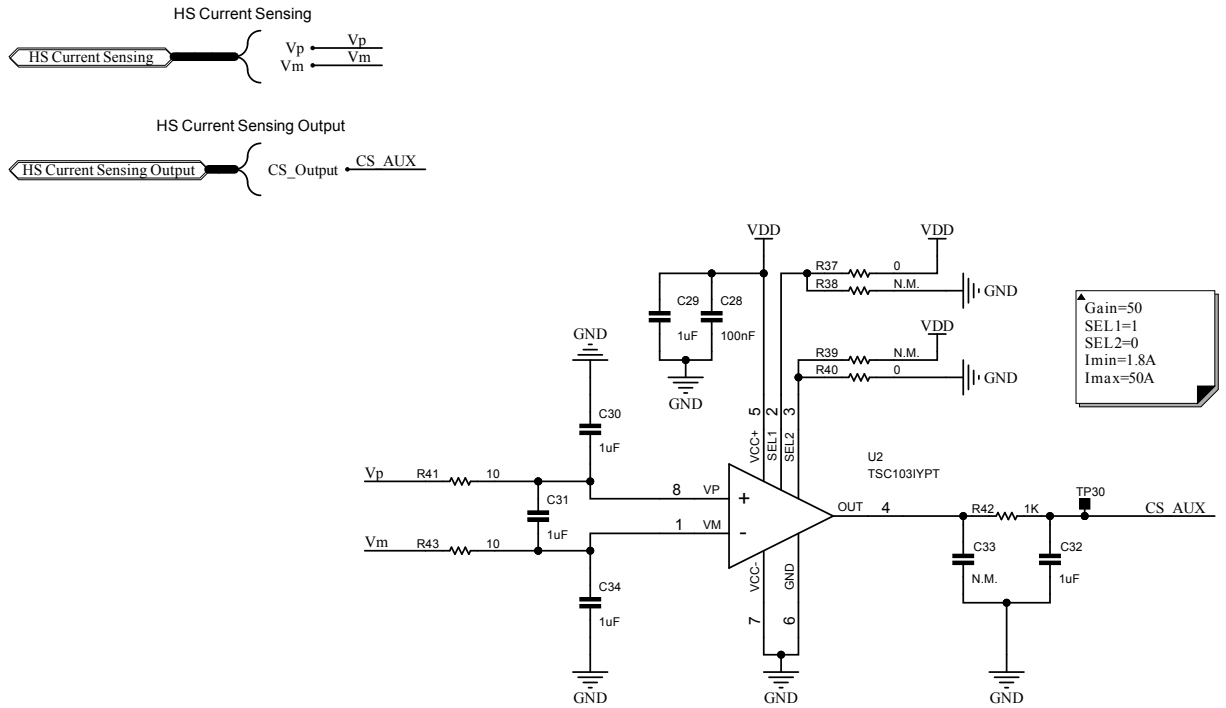
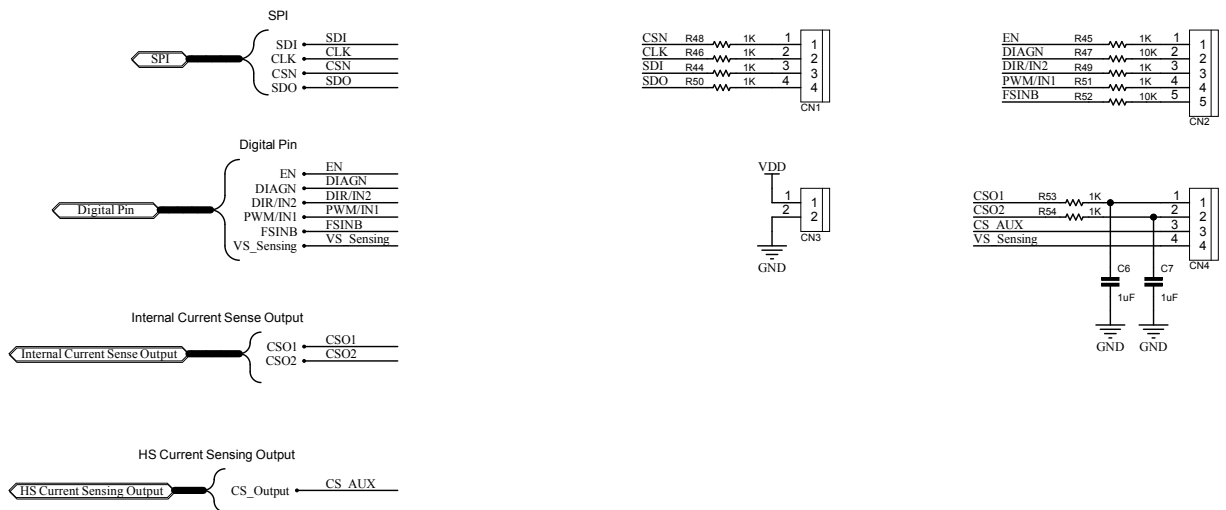

Figure 7. AEK-MOT-WINH92 circuit schematic (4 of 4)



3 Board versions

Table 1. AEK-MOT-WINH92 versions

Finished good	Schematic diagrams	Bill of materials
AEK\$MOT-WINH92A ⁽¹⁾	AEK\$MOT-WINH92A schematic diagrams	AEK\$MOT-WINH92A bill of materials

1. This code identifies the AEK-MOT-WINH92 evaluation board first version.

Revision history

Table 2. Document revision history

Date	Revision	Changes
23-Feb-2024	1	Initial release.

IMPORTANT NOTICE – READ CAREFULLY

STMicroelectronics NV and its subsidiaries (“ST”) reserve the right to make changes, corrections, enhancements, modifications, and improvements to ST products and/or to this document at any time without notice. Purchasers should obtain the latest relevant information on ST products before placing orders. ST products are sold pursuant to ST’s terms and conditions of sale in place at the time of order acknowledgment.

Purchasers are solely responsible for the choice, selection, and use of ST products and ST assumes no liability for application assistance or the design of purchasers’ products.

No license, express or implied, to any intellectual property right is granted by ST herein.

Resale of ST products with provisions different from the information set forth herein shall void any warranty granted by ST for such product.

ST and the ST logo are trademarks of ST. For additional information about ST trademarks, refer to www.st.com/trademarks. All other product or service names are the property of their respective owners.

Information in this document supersedes and replaces information previously supplied in any prior versions of this document.

© 2024 STMicroelectronics – All rights reserved