

EV Charging Inlet

multicomp PRO

**RoHS
Compliant**

Application

- Battery Electrical Vehicle (BEV), PHEV.

Features

- Provides low contact resistance and a minimum threshold of 10,000 mating cycles.
- Ergonomic, rugged, unibody design provides optimal comfort and intuitive handling.
- Complies with UL 2251 safety standards ensuring a high level of protection, even in severe environments.

Specification

Cable	: 3 × 14AWG+2 × 18AWG
Cable Length	: 5m
Product Color	: Black
Phase	: Single-phase
Rated Current	: 32A
Rated Voltage	: 250V AC
Force	: ≤100
Lifespan	: ≥10000
Flammability Rating	: UL 94V-0
IP (Mated)	: IP44
Operating Temperature	: -30 to 50

Diagram

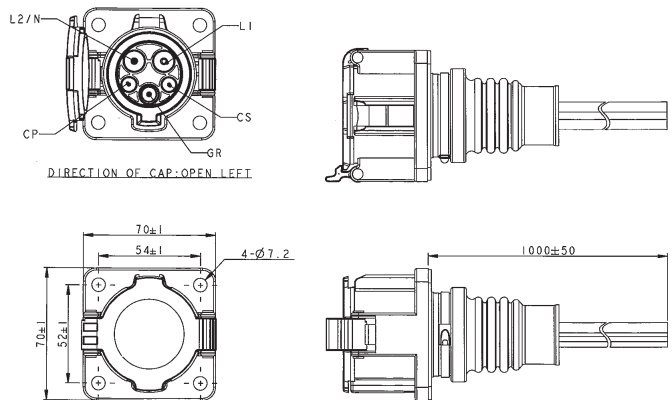

Note

1. Authentication Standard : UL 2251
2. Connector Meets : SAE J1772 Specifications
3. Current, Voltage & Wire Spec.

	Current & Voltage	Wire Spec.	Insulation Colour
L1	32A 240V AC	104AWG	Red
L2/N			Black
GR			Yellow/Green
CS	2A 30V DC	18AWG	White
CP			Orange

Part Number Table

Description	Part Number
EV Charging Inlet, Type 1, Single-Phase, 5m, Black, 32A	MP013705

Dimensions : Millimetres

Important Notice : This data sheet and its contents (the "Information") belong to the members of the AVNET group of companies (the "Group") or are licensed to it. No licence is granted for the use of it other than for information purposes in connection with the products to which it relates. No licence of any intellectual property rights is granted. The Information is subject to change without notice and replaces all data sheets previously supplied. The Information supplied is believed to be accurate but the Group assumes no responsibility for its accuracy or completeness, any error in or omission from it or for any use made of it. Users of this data sheet should check for themselves the Information and the suitability of the products for their purpose and not make any assumptions based on information included or omitted. Liability for loss or damage resulting from any reliance on the Information or use of it (including liability resulting from negligence or where the Group was aware of the possibility of such loss or damage arising) is excluded. This will not operate to limit or restrict the Group's liability for death or personal injury resulting from its negligence. Multicomp Pro is the registered trademark of Premier Farnell Limited 2019.

Newark.com/multicomp-pro
Farnell.com/multicomp-pro
sg.element14.com/b/multicomp-pro

multicomp PRO