



PUI audio



Data Sheet

AR027150MS-2-R

Specifications

Parameters	Values	Units
Rated Input Power	15	mWatts
Max Input Power	30	mWatts
Impedance	150 ± 15%	Ohms
Sensitivity (SPL @ 1kHz)	118 ± 3	dB Pa/V
Frequency Range	20 ~ 10,000	Hz
Frame Material	ABS	-
Magnet Material	NdFeB	-
Weight	5.2	Grams
Environmental Compliances	ROHS/REACH	-
Polarity	When positive voltage is applied to the positive terminal, the diaphragm will move outward	-
Operating Temperature	-20 ~ +60	°C
Storage Temperature	-30 ~ +60	°C

Measurement Method (measured with 1mW)

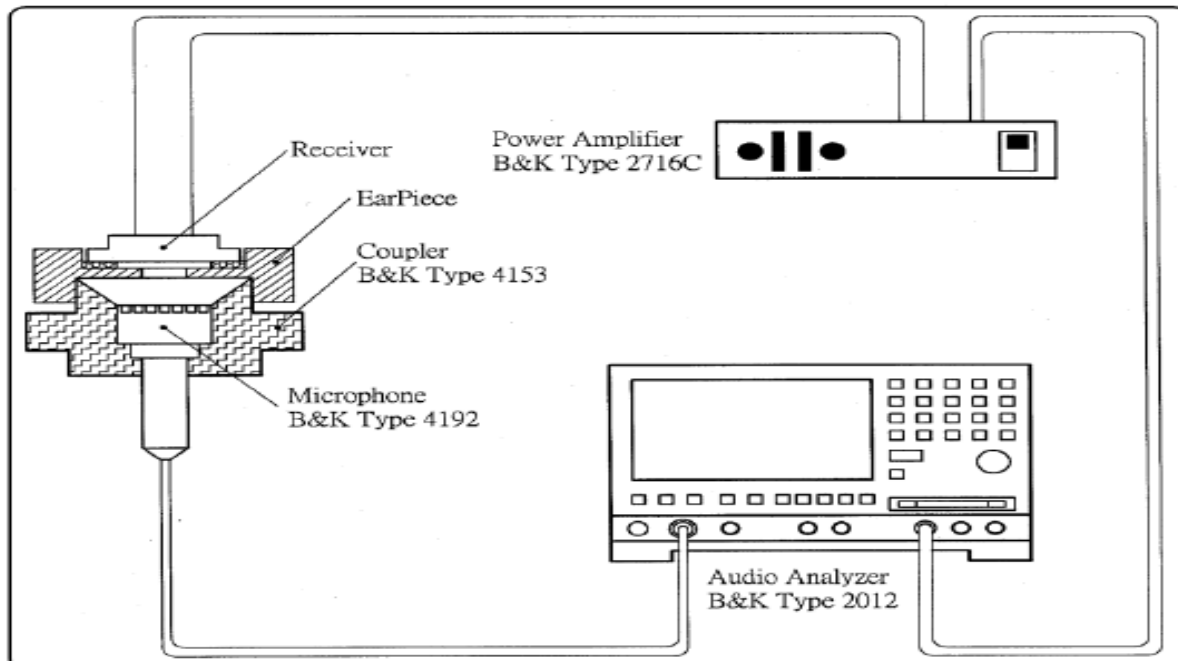

Frequency Response (measured at 15 mW)

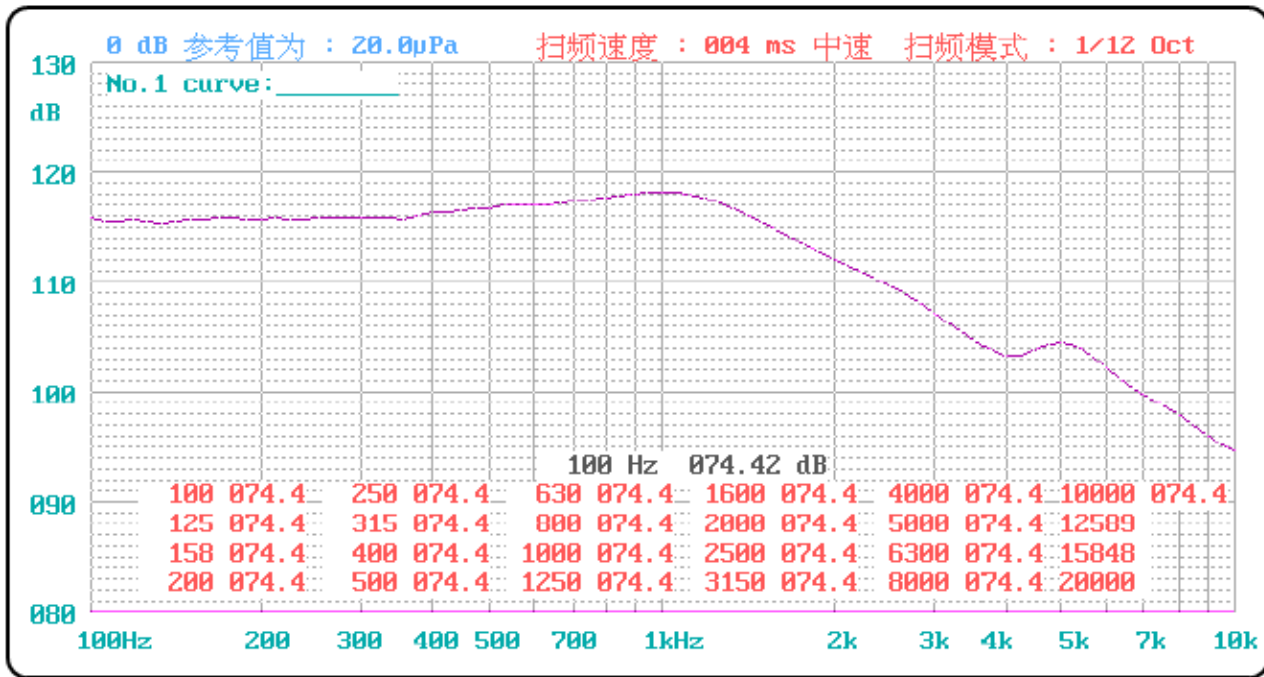

Reliability Testing

Type of Test	Test Specifications
High Temperature Test	96 hours at +80°C ± 3°C followed by three hours in normal room temperature
Low Temperature Test	96 hours at -40°C ± 3°C followed by three hours in normal room temperature
Humidity Test	96 hours at +40°C ± 3°C with relative humidity at 95% followed by 3 hours in normal room temperature
Temperature Cycle Testing	The part shall be subjected to 5 cycles using the following procedure: Low temperature: -40°C±3°C High temperature:+80°C±3°C Cycle: 1 hour/cycle each
Vibration Test	10 to 55 to 10 Hz sine sweep, 15 minutes per cycle @ 5G constant. 2 hours in each axis X, Y, and Z.
Drop Test	Drop the speakers onto a 20mm thick board 10 times from a height of 100cm, once each side
Load Test and Max Power Test	White noise is applied at the speakers rated power for 96 hours at room temperature; max power is applied for 1 minute on, 2 minutes off; 10 cycles.

After each test, the speaker's SPL shall be ±3 dB of the original SPL

Dimensions (Positive is the left spring contact in the suggested pad layout drawing)

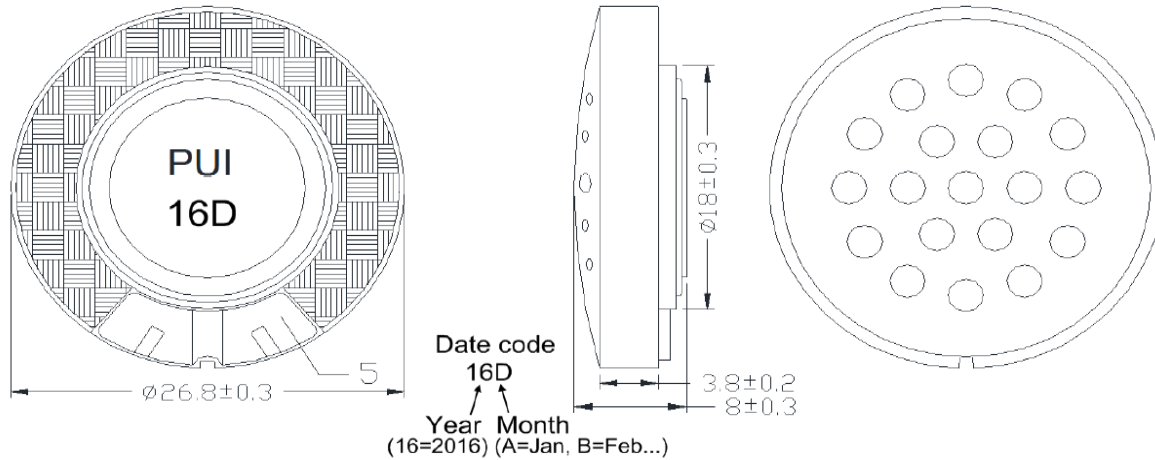

Packaging

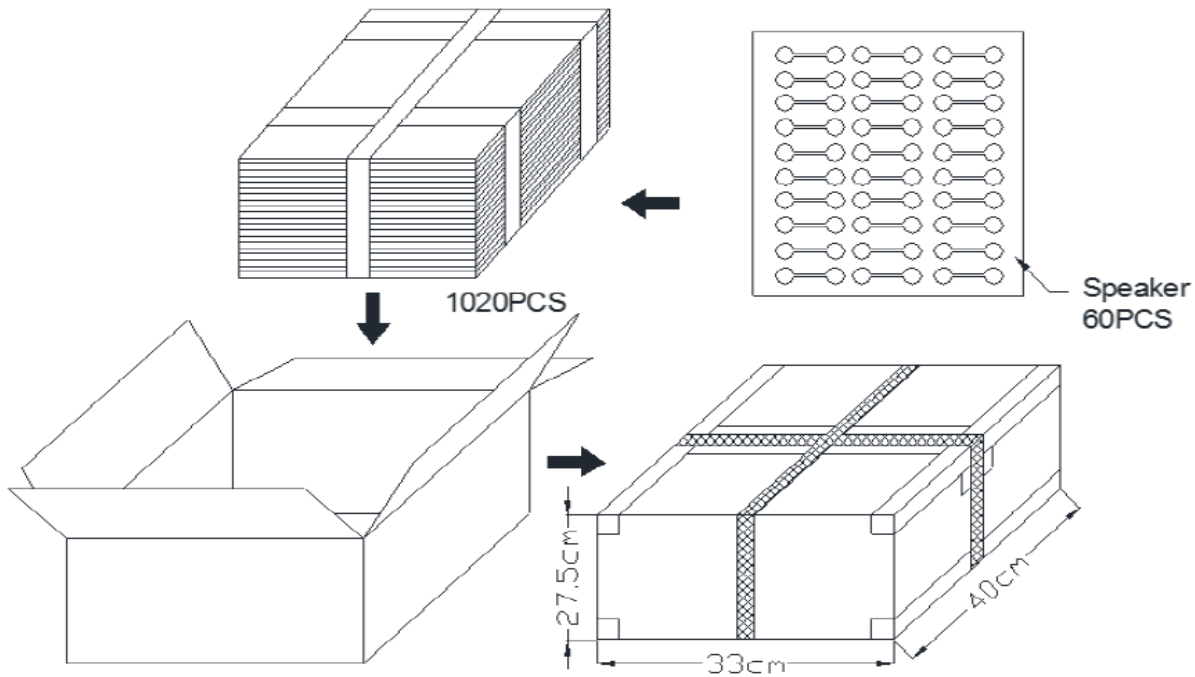

Specifications Revisions

Revision	Description	Date
A	Released from Engineering	10/1/2018

Note:

- Unless otherwise specified:
 - All dimensions are in millimeters.
 - Default tolerances are ± 0.5 mm and angles are $\pm 3^\circ$.
- Specifications subject to change or withdrawal without notice.