

# SPECIFICATIONS

PARAMETERS	VALUES	UNITS
RATED VOLTAGE (SQUARE WAVE)	6	Vpk
OPERATING VOLTAGE RANGE	4 ~ 8	Vpk
RATED CURRENT (MAX)	40	mA
COIL RESISTANCE	50 ± 5	OHM
MINIMUM SPL @ 10 CM	90	dBA
RESONANT FREQUENCY	2,048 ± 500	Hz
OPERATING TEMPERATURE	-30 ~ +70	°C
STORAGE TEMPERATURE	-40 ~ +85	°C
HOUSING MATERIAL	NORYL	-
TERMINAL MATERIAL	Sn PLATED COPPER	-
WEIGHT	2	grams

THIS DOCUMENT CONTAINS DATA PROPRIETARY TO PUI AUDIO, INC. ANY USE OR REPRODUCTION, IN ANY FORM, WITHOUT PRIOR WRITTEN PERMISSION OF PUI AUDIO, INC. IS PROHIBITED.

©2010, PUI AUDIO Inc.

# REVISION HISTORY

LTR	DESCRIPTION	DATE	APPROVED
-	RELEASED FROM ENGINEERING	9/24/2004	
A	REMOVED LEAD FREE ADDED RoHS NOTE	8/10/2005	
B	REVISED TERMINAL MATERIAL	3/21/2006	
C	REVISED TO INVENTOR 3-D DRAWING TEMPLATE	10/15/2007	B.R.
D	REVISED MIN SPL LEVEL	2/24/2014	B.R.
E	REVISED TEMPS AND WEIGHT	2/19/2020	M.L.

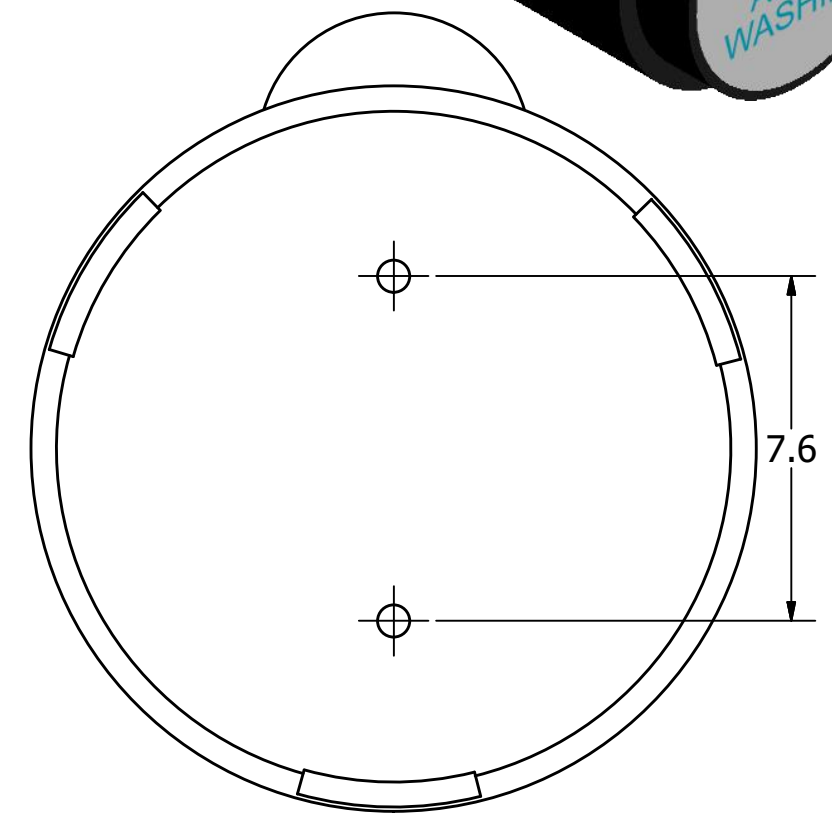
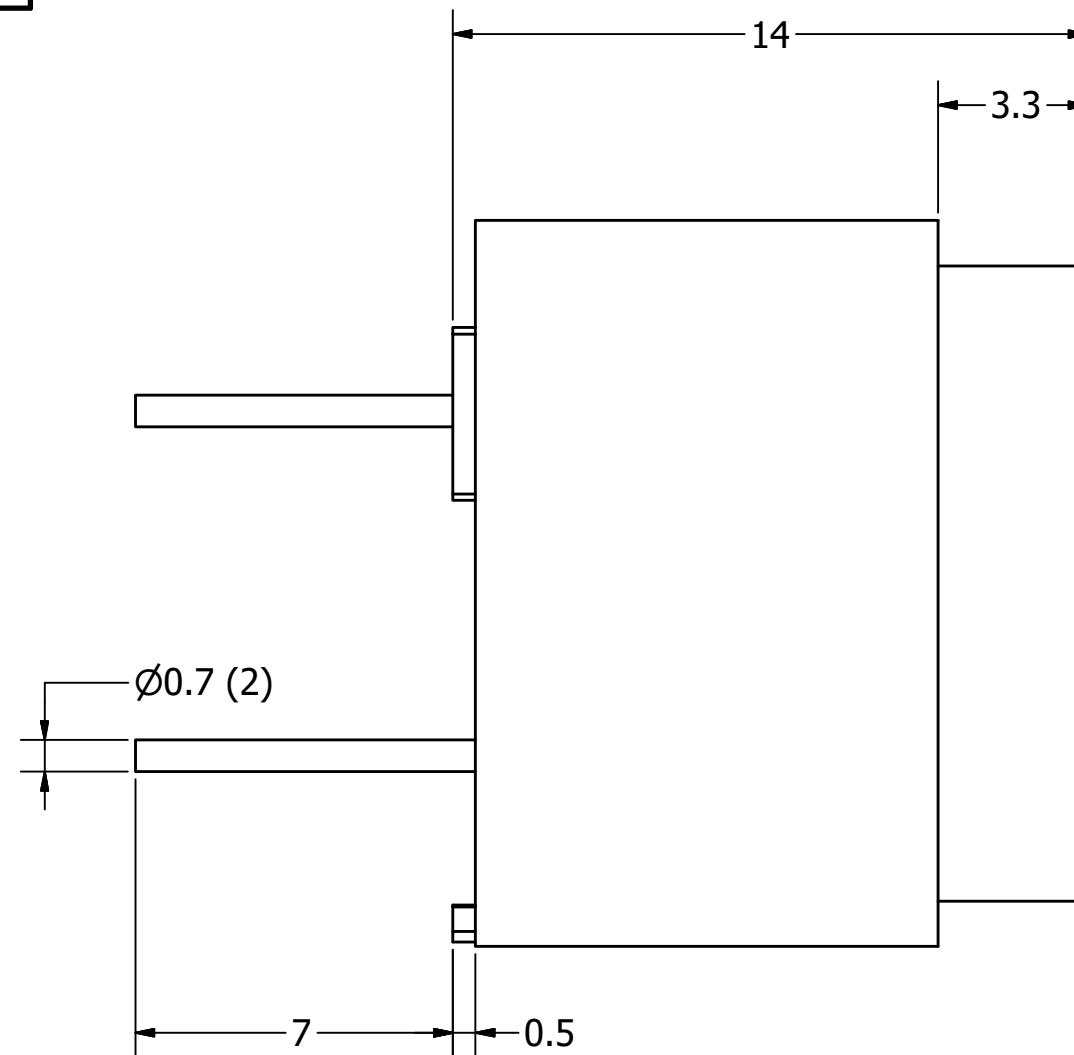
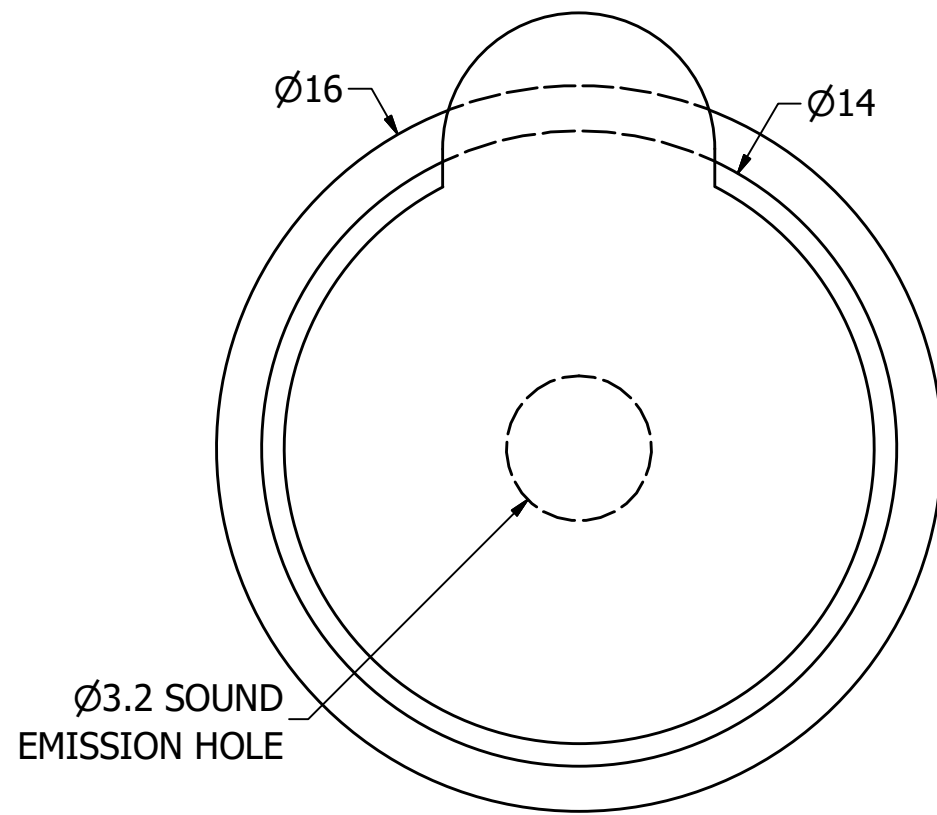

## NOTES:

1. ALL DIMENSIONS ARE IN MILLIMETERS.
2. SPECIFICATIONS SUBJECT TO CHANGE OR WITHDRAWAL WITHOUT NOTICE.
3. THIS PART IS RoHS 2015/863/EC COMPLIANT.
4. WAVE SOLDER AND WASH ALLOWED.

UNLESS OTHERWISE SPECIFIED: DIMENSIONS ARE IN MILLIMETERS, TOLERANCES ARE ±0.5 AND ANGLES ARE ±3°.	SIZE <b>A3</b>	Designed by	Date	Checked by	Date	Approved by	Date	Drawn Date		
		R.A.C.	9/24/2004			R.W.	9/24/2004	10/15/2007		
AT-1620-TWT-R.idw				<b>AT-1620-TWT-R</b>			Transducer (Electro-Mech)		Edition -	Sheet 1 / 1