



PUI audio



Data Sheet

AS01506MS-WP-LW100-R

PUI Audio's **Mobile Series** line of speakers and receivers is designed for cutting-edge applications such as smart watches and pendants, Wi-Fi enabled security devices and action cameras, mobile radios and smart phones, as well as IoT devices. Each **Mobile Series** product features an IP67-rated face for protection against dust and water ingress.

The six-ohm 15mm x 11mm **AS01506MS-WP-LW100-R** speaker is designed for high fidelity audio reproduction in the thinnest size possible.

Features:

- PEEK diaphragm for flat frequency response
- 93 dB output (2.45V @ 10cm)
- High-energy neodymium motor
- Dustproof and waterproof IP67-rated face
- Double-sided tape, integrated grill, and rear foam pad
- 100mm lead wires for quick electrical connection

Specifications

Parameters	Values	Units
Rated Input Power	0.8	Watts
Max Input Power	1.0	Watts
Impedance	6 ± 15%	Ohms
Sensitivity (SPL @ 2.2V/10cm) At 2 kHz in 1cc enclosure	93 ± 3	dB
Resonant Frequency (free air/in 1cc enclosure)	550 ± 20% (1.0Vrms, 10cm) 850 ± 20% (1cc box 2.2Vrms, 10cm)	Hz
Frequency Range	Fo ~ 20,000	Hz
Frame Material	PPA	-
Magnet Material	NdFeB	-
Weight	1.5	Grams
Environmental Compliances	ROHS/REACH	-
Ingress Protection Rating	IP67	-
Buzz, Rattle, etc.	Should not be audible with 2.2V sine wave from 200 Hz to 2 kHz in 1cc enclosure	-
Polarity	When positive voltage is applied to the positive terminal, the diaphragm will move outward	-
Storage Temperature	-40 ~ +85	°C
Operating Temperature	-20 ~ +70	°C

Measurement Method (measured with 2.2V, Temperature: 15 ~ 35°C, Relative Humidity: 25%~70%)

Standard test condition of speaker

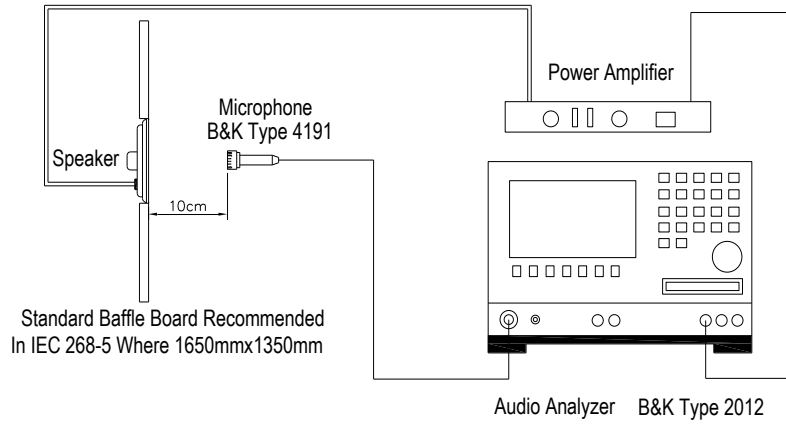

Frequency Response (measured with 2.2V @ 10cm in 1cc enclosure)

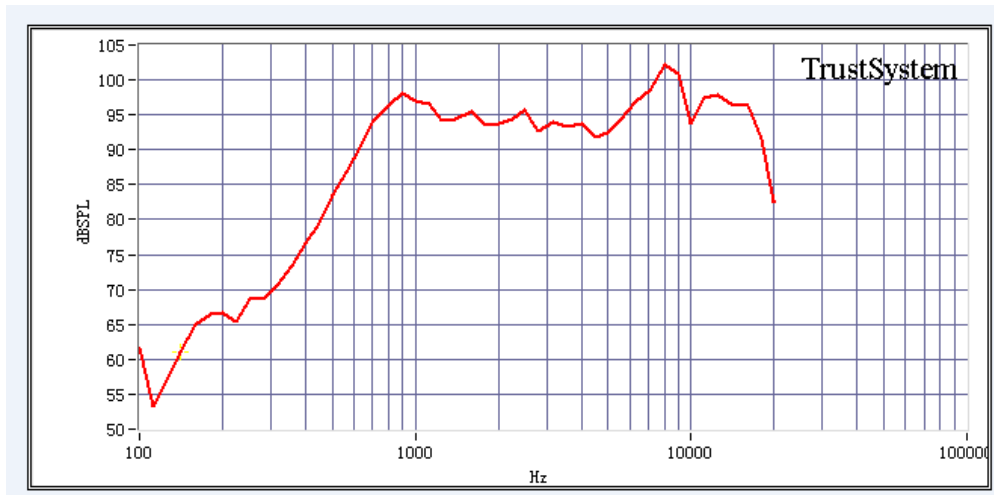

Impedance Response (measured in 1cc enclosure)

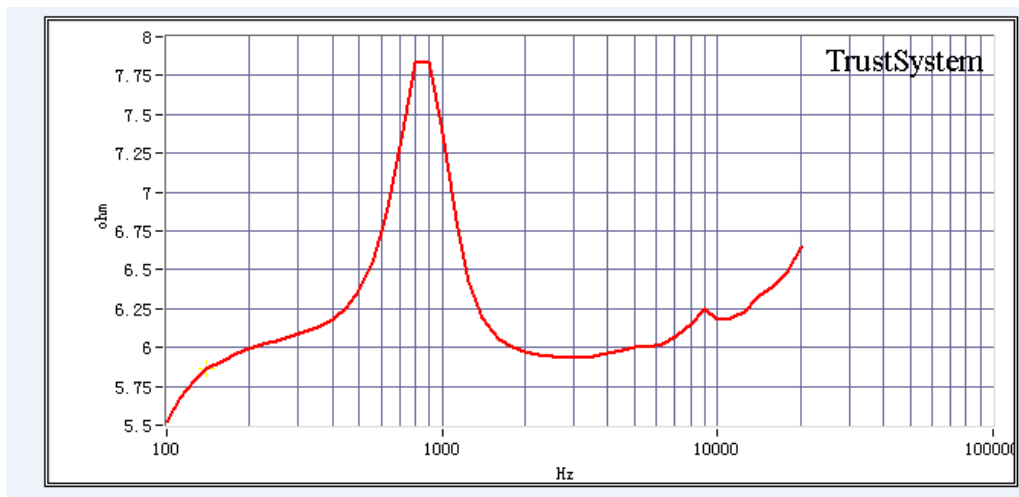

Reliability Testing

Type of Test	Test Specifications
High Temperature Test	96 hours at +85°C ± 3°C followed by three hours in normal room temperature
Low Temperature Test	96 hours at -40°C ± 3°C followed by three hours in normal room temperature
Humidity Test	96 hours at +40°C ± 3°C with relative humidity at 90%~95% followed by 6 hours in normal room temperature
Temperature Cycle Testing	The part shall be subjected to 12 cycles using the following procedure: Low temperature: -40°C±3°C High temperature:+80°C±3°C Cycle: 2 hours at High, 5 minutes High to Low, 2 hours at Low, 5 minutes Low to High
Vibration Test	10 to 55 to 10 Hz sine sweep, per minute @ 1.5mm amplitude 2 hours in each axis X, Y, and Z.
Drop Test	Mount speaker to 100g fixture, drop fixture 1.5 meters, twice per side and twice for each corner
Load Test	White noise is applied at the speakers rated power for 96 hours at room temperature with speaker in 1cc enclosure.

After each test, the speaker's SPL shall be ±3 dB of the original SPL

Dimensions

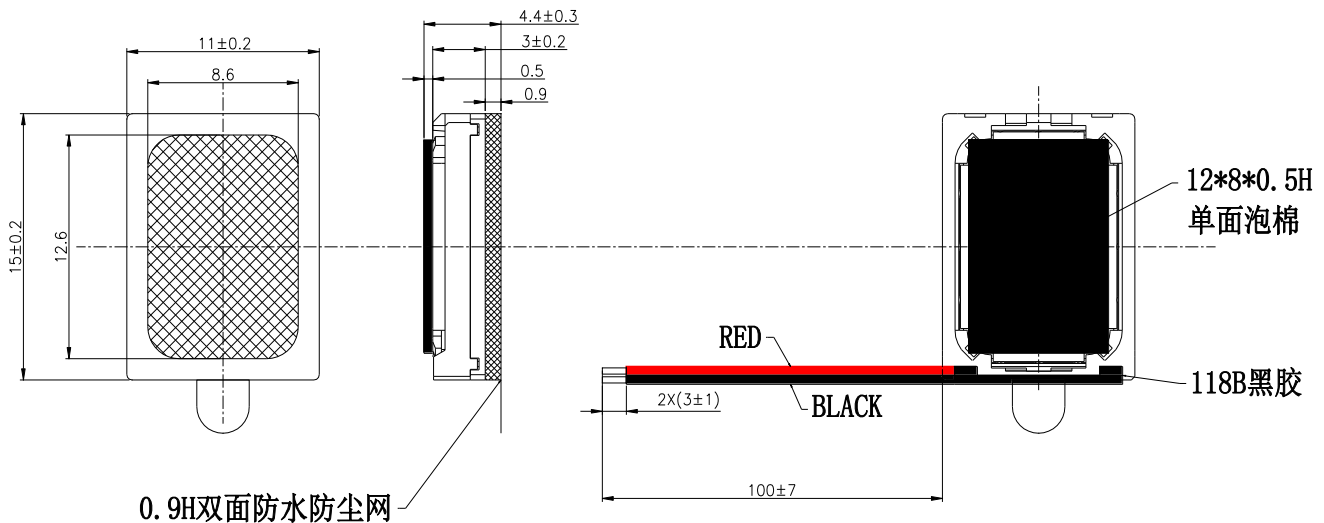

WIRE:UL1569 28#

技术要求:1. 未注公差按照±0.2

Packaging

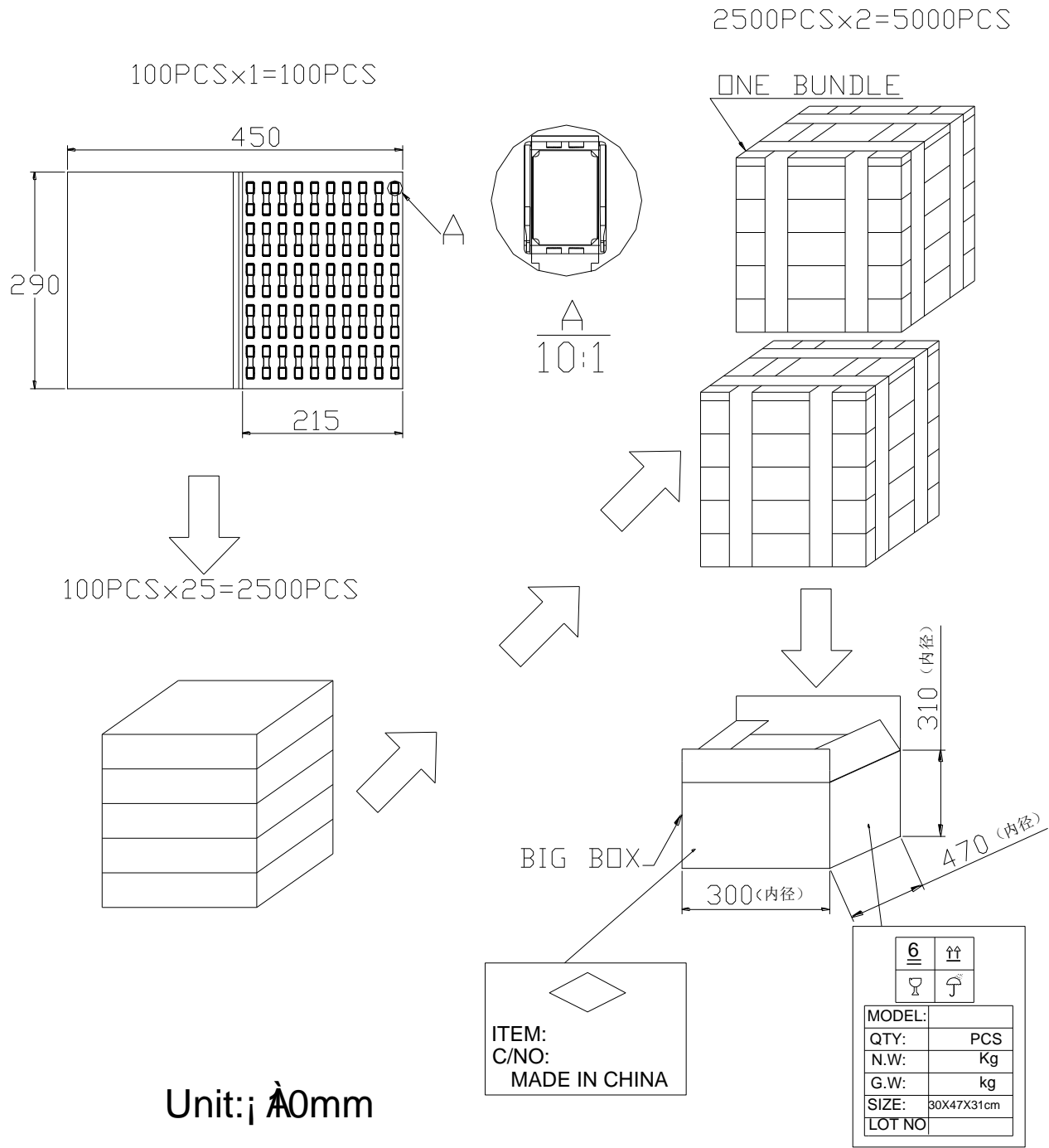

Specifications Revisions

Revision	Description	Date
-	Released from Engineering	11/2/2018
A	Update PUI Logo, Revised Power Ratings, Update Drawing	4/4/2023

Note:

1. Unless otherwise specified:
 - A. All dimensions are in millimeters.
 - B. Default tolerances are $\pm 0.5\text{mm}$ and angles are $\pm 3^\circ$.
2. Specifications subject to change or withdrawal without notice.