



PUIaudio



Data Sheet

HD-EMB1104-SM-2

Features:

- Designed to be driven with 2.7 VDC
- Surface mount motor directly soldered to the PCB board
- Recommended PCB layout shown for easy implementation
- Generates 14,000 RPMs with no more than 50 dBA acoustic noise

Specifications

Parameters	Values	Units
Rated Voltage	2.7	V _{DC}
Starting Voltage	2.3	V _{DC}
Operating Voltage Range	2.3 ~ 3.2	V _{DC}
Direction of Rotation	CW	-
Vibration Strength	0.35	G
Terminal Resistance	33 ± 6	Ohms
Insulation Resistance	> 1M	Ohms
Rated Speed	14,000 ± 2,500	RPM (@ 2.7 V _{DC})
Rated Current (Max)	85	mA (@ 2.7 V _{DC})
Stall Current (Max)	90	mA (@ 2.7 V _{DC})
Shaft Pull Strength	> 3.0	kgf
Shaft End Play (Max)	0.3	mm
Mechanical Noise (Max)	50	dBA
Environmental Compliances	RoHS/REACH	-
Rotating Mass	0.23 ± 10%	g
Actuator Mass	0.60 ± 10%	g
Storage Temperature	-40 ~ +85	°C
Operating Temperature	-20 ~ +70	°C

Reliability Testing

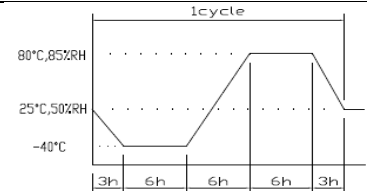
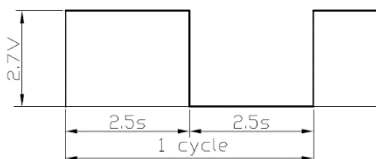
Type of Test	Test Specifications	Pass/Fail Criteria
High Temperature	Temperature: +80±2°C Test Duration: 96 hours	After each test, motors rest for 4 hours at room temperature. After rest, the motor shall meet the following initial values: <ol style="list-style-type: none"> 1) Rated Speed: -30%/+50% initial 2) Rated Current: ± 30% initial 3) Starting Voltage: 2.3 V_{DC}
Low Temperature	Temperature: -40±2°C Test Duration: 96 hours	
High Humidity	Temperature: +60±2°C Humidity: 90 ~ 95 RH Test Duration: 96 hours	
Humidity Cycle	 Test Cycles: 6	
Thermal Shock	Temperature Range: -40 <-> +80°C Test Duration: 30 minutes Test Cycles: 50	
Free Drop	Drop from listed drop height twice in ±X, ±Y, ±Z directions (12 total): Jig Mass: 100 grams (including motor) Drop Height: 1.5 meters Test Cycles: 2 per drop axis	
Vibration	Amplitude: 1.5mm p-p Frequency: 10 ~ 55 Hz Cycle Time: 20 min Cycle: 10 Hz ~ 55 Hz ~ 10 Hz Test Orientation: X, Y, Z Test Duration: 2 hours	
Lifetime	 Temperature: Room Temperature Test Cycles: 300,000 (@ 2.7V _{DC})	After 100,000 cycles, the motor performance shall meet the following initial values: <ol style="list-style-type: none"> 1) Rated Speed: -30%/+50% initial 2) Rated Current: ± 30% initial 3) Starting Voltage: 2.3 V_{DC}
	Temperature: +55°C Test Cycles: 53,000 (@ 2.7V _{DC})	After 300,000 cycles, the motor should function.
	Temperature: -20°C Test Cycles: 53,000 (@ 2.7V _{DC})	After 53,000 cycles, the motor performance shall meet the following initial values: <ol style="list-style-type: none"> 1) Rated Speed: -30%/+50% initial 2) Rated Current: ± 30% initial 3) Starting Voltage: 2.3 V_{DC}

After testing, each motor must achieve the listed Pass/Fail Criteria for the appropriate test.

Measurement Methods

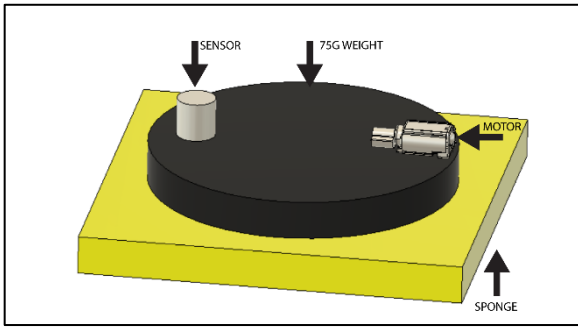

Vibration Test Jig

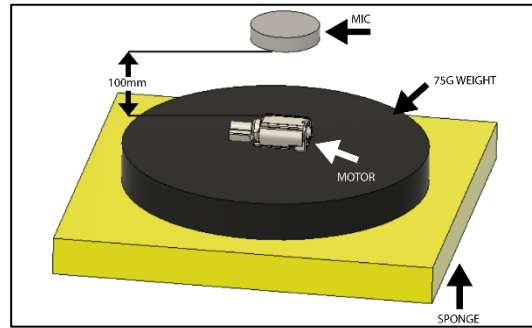

Noise Measurement Jig

Dimensions

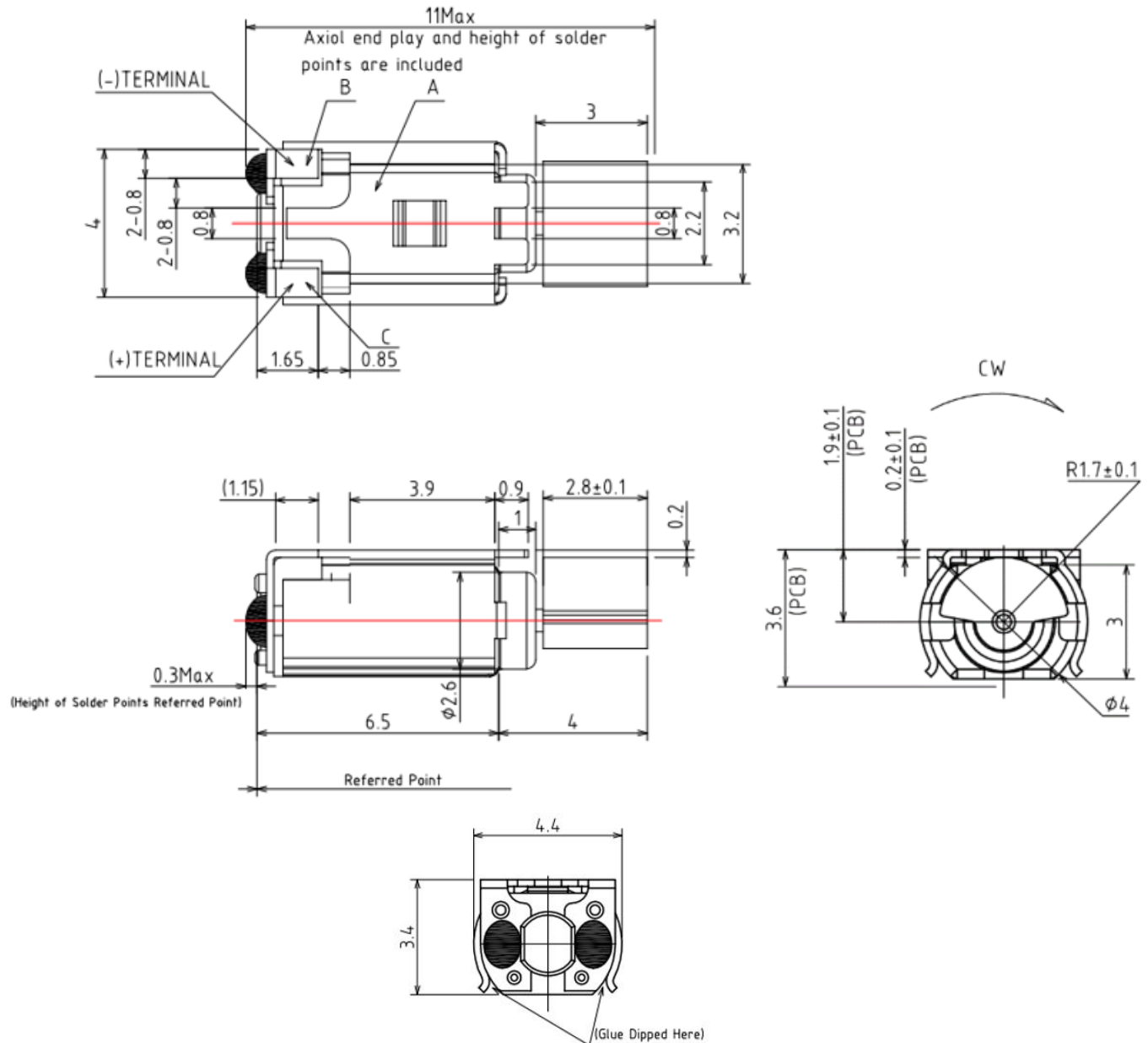

PCB Land Pattern

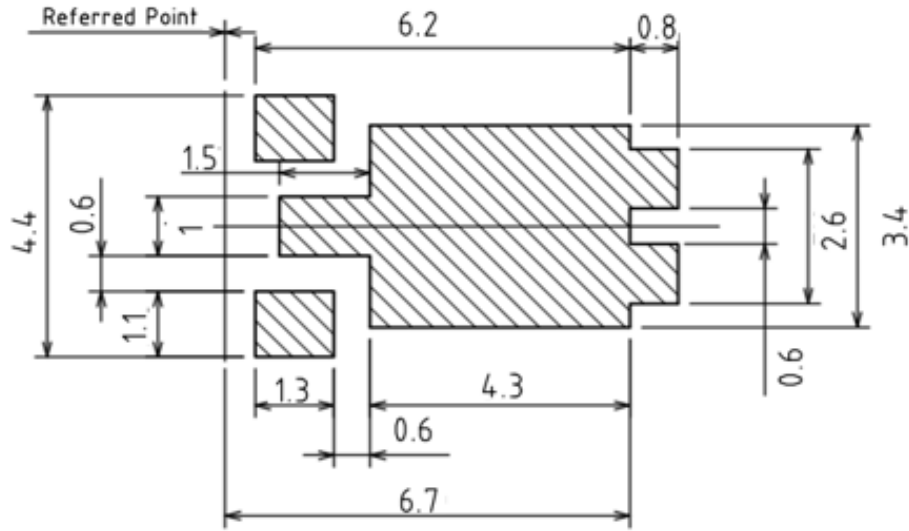

*This land pattern is advisory only and its use or adaptation is entirely voluntary. PUI Audio disclaims all liability of any kind associated with the use, application, or adaptation of this land pattern.

Recommend Soldering Procedure

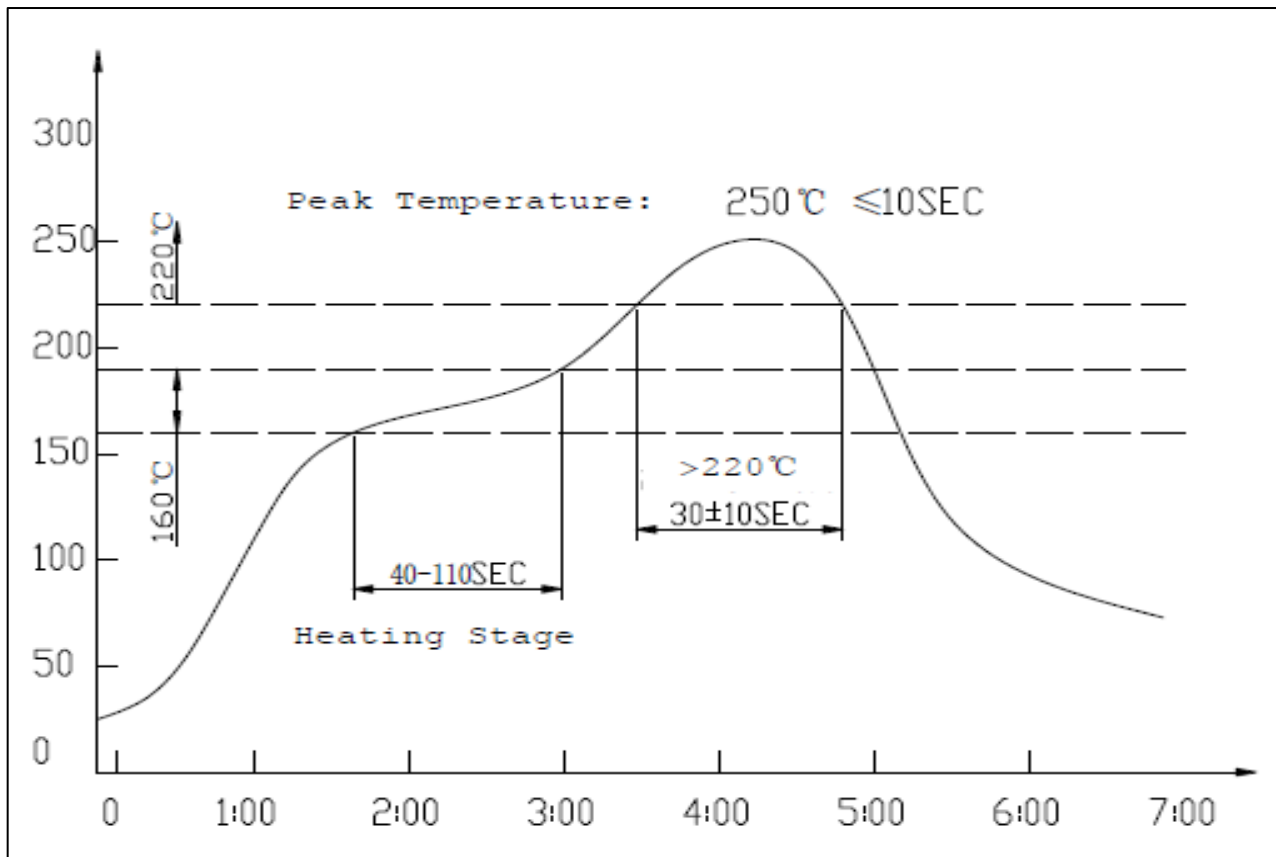

Packaging

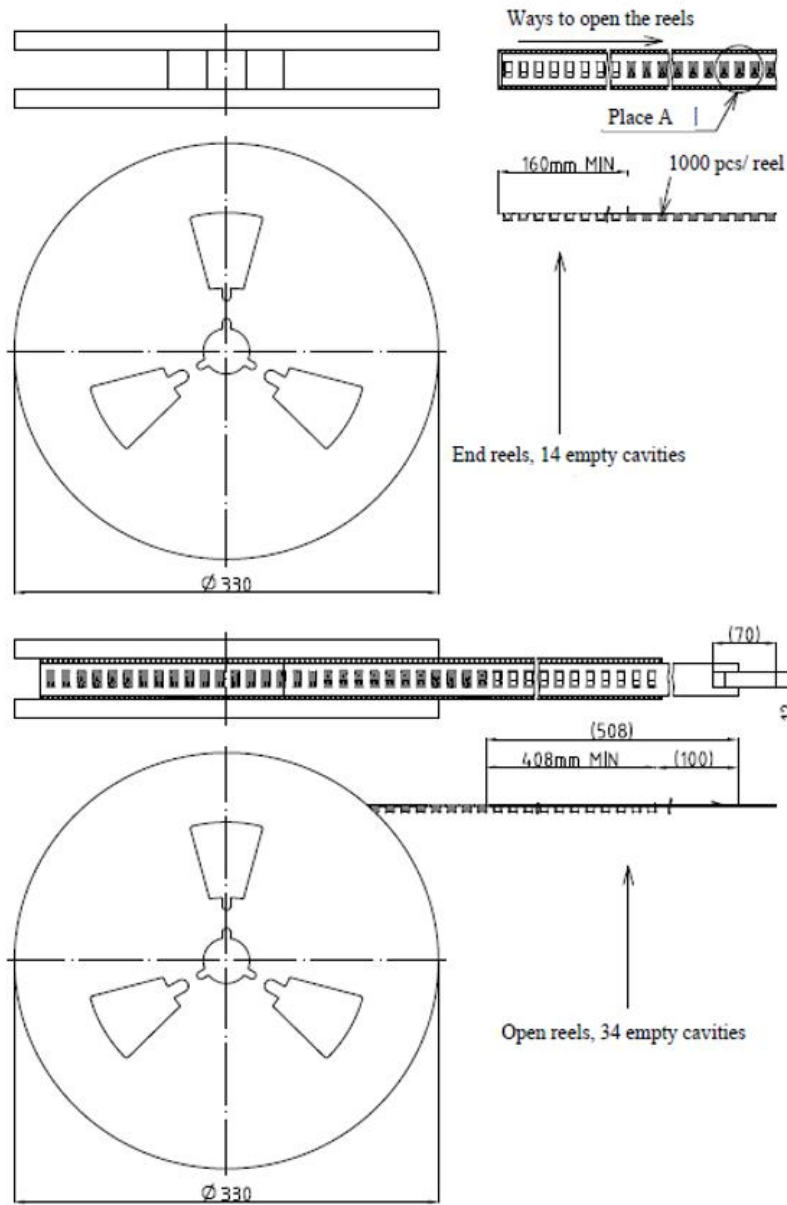
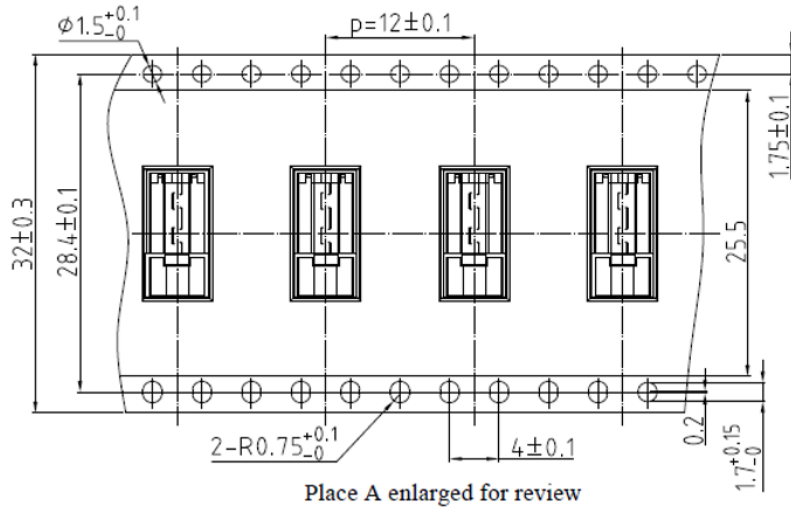

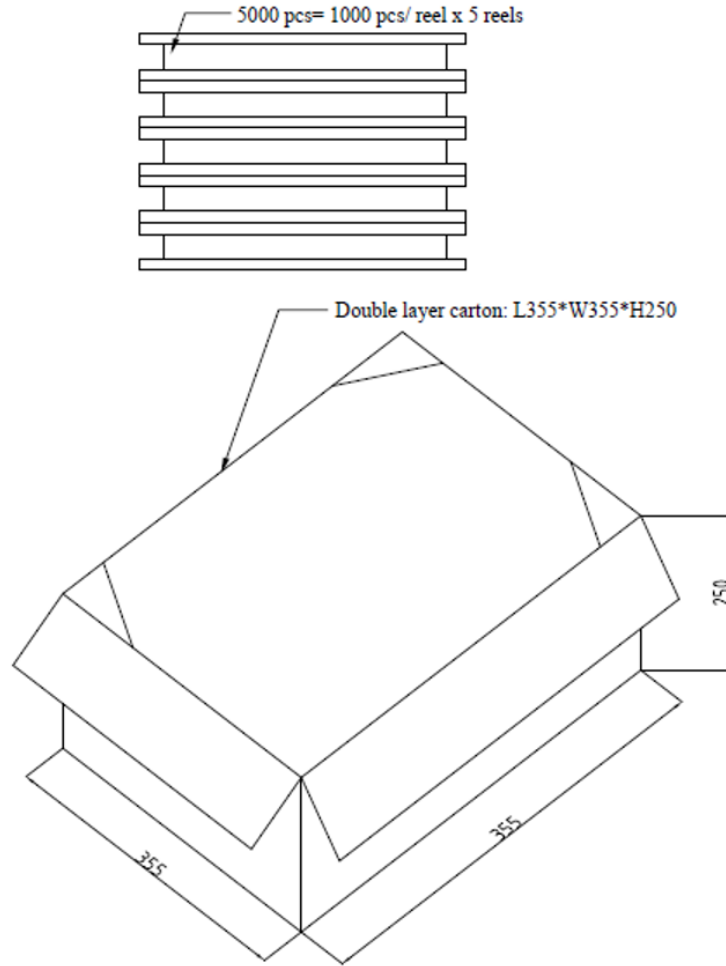

Specifications Revisions

Revision	Description	Date
A	RELEASED FROM ENGINEERING	02/16/2023
B	Update 3D image, drawing detail, and Measurement Method	11/10/2023

Note:

1. Unless otherwise specified:
 - A. All dimensions are in millimeters.
 - B. Default tolerances are $\pm 0.5\text{mm}$ and angles are $\pm 3^\circ$.
2. Specifications subject to change or withdrawal without notice.