



# PUI audio



Data Sheet

AT-1220-TT-3-R

## Features:

- 1.5V0-pk, 2048Hz Magnetic Transducer
- Pin Type

## Specifications

Parameters	Values	Units
Rated Voltage	1.5	V0-p
Operating Voltage Range	1 ~ 3	V0-p
Current Draw at Rated Voltage	10	mA
Coil Resistance	50 ± 7.5	Ohm
Minimum SPL @ 10cm	73	dBA
Resonant Frequency	2,048±500	Hz
Housing Material	NORYL	-
Terminal Material	Sn Plated Copper	-
Weight	2	Grams
Acceptable Soldering Methods	Hand Solder Only	350C/2-3 secs
Environmental Compliances	RoHS/REACH	-
Storage Temperature	-40 ~ +85	°C
Operating Temperature	-30 ~ +70	°C

**\*Wave solder and washing not allowed.**

## Measurement Method (Temperature: 25±3°C; Relative Humidity: 60% ~ 70%)

Standard Test Fixture (Distance: 10cm, 1.5 V0-p, 2048Hz square wave)

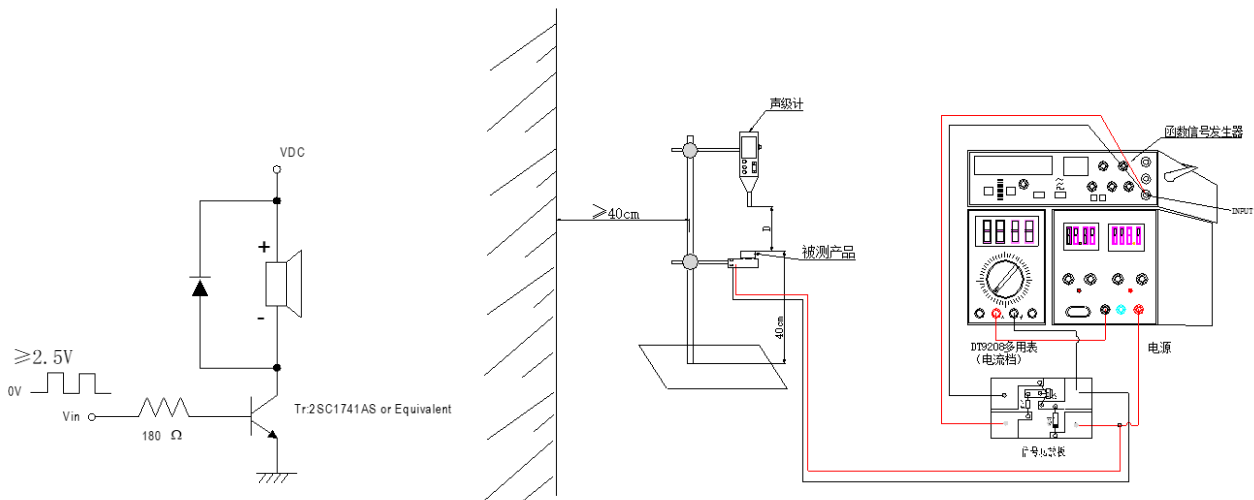

## Reliability Testing

Type of Test	Test Specifications
High Temperature Test	96 hours at +85°C±2°C then rest at room temperature for 2 hours without applying power
Low Temperature Test	96 hours at -40°C±2°C then rest at room temperature for 2 hours without applying power
Humidity Test	96 hours at +40°C±2°C with relative humidity at 90-96% then rest at room temperature for 2 hours without applying power
Temperature Cycle Testing	<p>Test for 5 cycles without applying power, then expose to room temperature for 2 hours</p>
Vibration Test	<p>Amplitude: 1.5mm Time : 1min/axis</p> <p>In X,Y,Z directions for 2 hours each (6 hours total)</p>
Drop Test	Drop a piece from a height of 1m to the surface of a 10mm thick board, drop the piece on the X, Y, Z axis

After these tests, the piece should test within ± 5dB of the original SPL

## Dimensions

侧印银: AT-1220-TT  
-3-R ⊕YM

(日期代码格式: YM:年月, A-L代表月, 如: 22B)

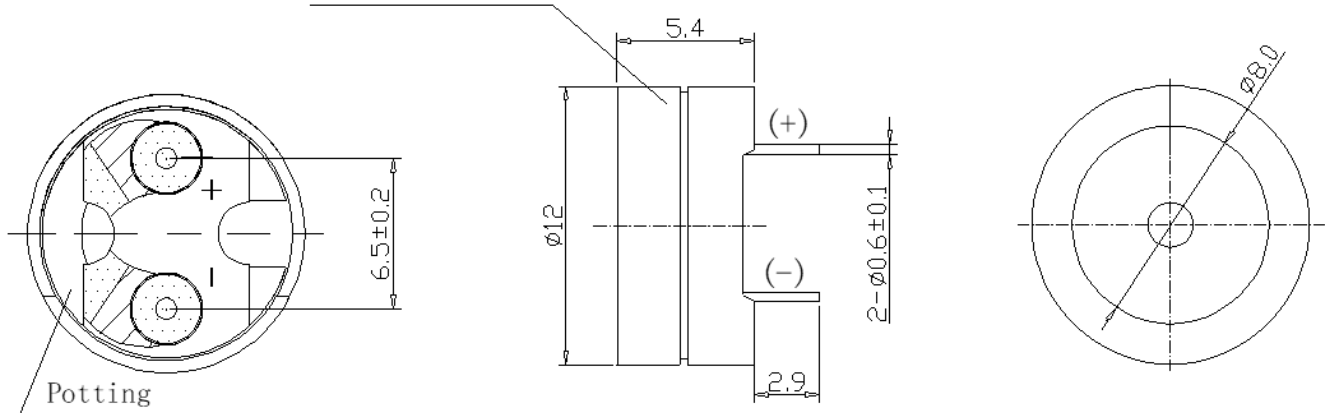

## Packaging

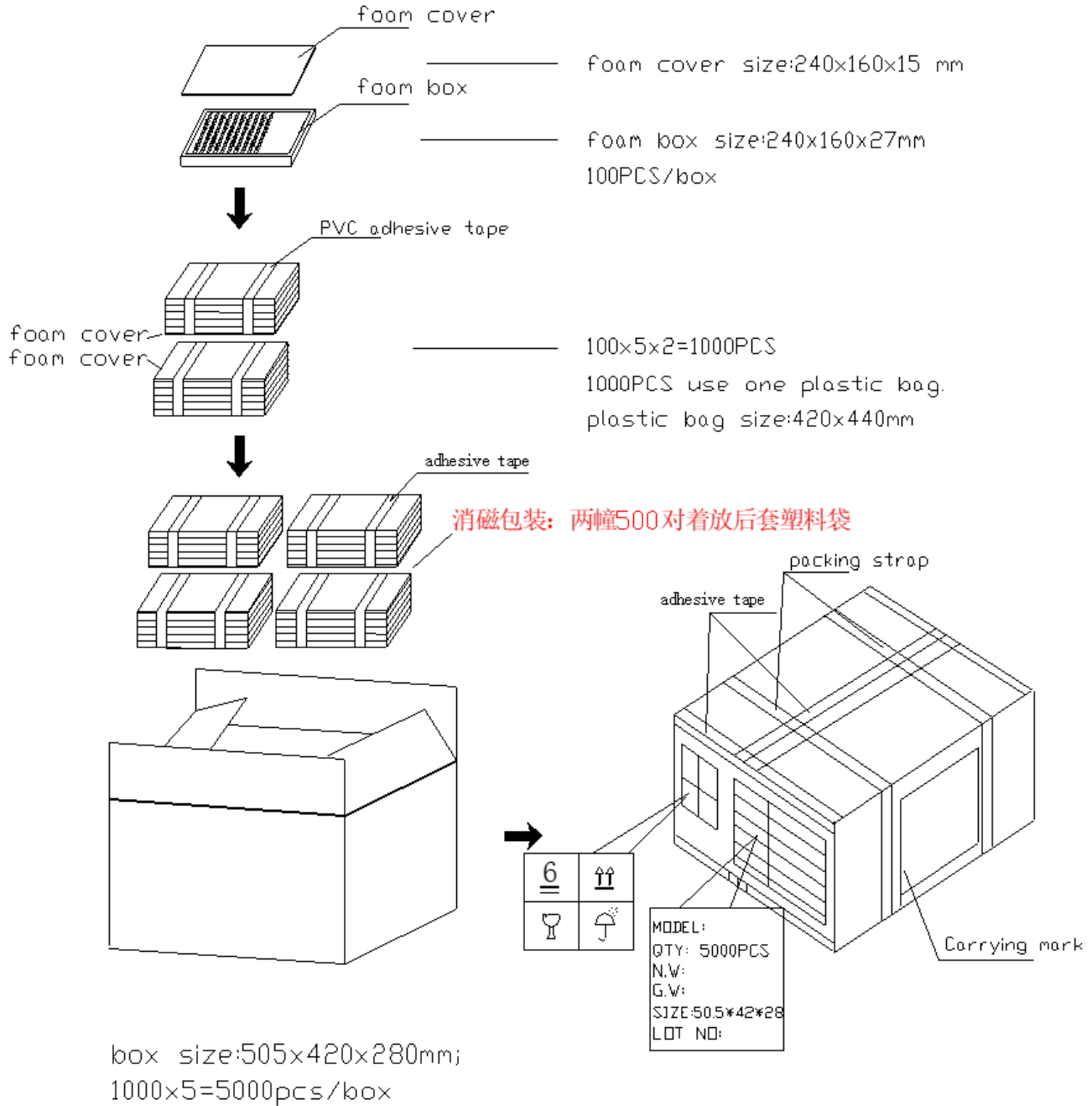

### Specifications Revisions

Revision	Description	Date
-	RELEASED FROM ENGINEERING	01/04/2005
A	Changed Part No.	01/06/2005
B	Removed Lead Free ROHS Note	08/10/2005
C	Revised to Inventor 3D Template	05/07/2008

#### Note:

- Unless otherwise specified:
  - All dimensions are in millimeters.
  - Default tolerances are  $\pm 0.5\text{mm}$  and angles are  $\pm 3^\circ$ .
- Specifications subject to change or withdrawal without notice.