

Data Sheet

AMM-3538-2-B

Features:

The AMM-3538-2-B analog MEMS microphone features a specialized pre-amplification ASIC that provides high sensitivity and high SNR output from a capacitive audio sensor. It's packaged for surface mounting and high temperature reflow assembly.

- -38dB sensitivity
- 66dB Signal-to-Noise
- Analog output
- Small 3.5mm x 2.65mm surface-mount package

Specifications ($V_{DD} = 2.7V$, $T_A = 23\pm 2^\circ C$, $RH = 55\pm 10\%$, unless otherwise specified.)

Parameter	Test Condition	Value	Unit
Sensitivity	$f_{IN} = 1\text{ kHz}$ 94dB SPL	-39 (min) -38 (typ) -37 (max)	dB
Supply Voltage		2.0 (typ)	V_{DD}
Supply Voltage Range		1.6 (min) 3.6 (max)	V_{DD}
Output Impedance	$f_{IN} = 1\text{ kHz}$	300 (max)	Ω
Supply Current	$1.6V \leq V_{DD} \leq 3.6V$	200 (max)	μA
Signal-to-Noise Ratio	$f_{IN} = 1\text{ kHz}$ 94dB SPL A-weighted	66 (typ)	dB
Frequency Range	See Frequency Response Curve for response limits	20 – 20k	Hz
Total Harmonic Distortion	$f_{IN} = 1\text{ kHz}$ 94dB SPL	0.5 (max)	%
Acoustic Overload Point (AOP)	$f_{IN} = 1\text{ kHz}$ 10% THD	124 (typ)	dB
Power Supply Rejection	100mV _{PP} 217 Hz square wave on V_{DD} A-weighted	-100 (typ)	dB

Physical Properties

Parameter	Condition	Value	Unit
Directivity		Omnidirectional	
Weight		0.3 (max)	Grams
Operating Temperature		-40 (min) 85 (max)	°C
Storage Temperature		-40 (min) 100 (max)	°C
MSL (Moisture Sensitivity Level)*		Class 1	
Acceptable Soldering Methods		See below for reflow soldering information	
Environmental Compliances		RoHS/Halogen Free	

*MSL level dependent on product remaining in sealed packaging until use

Absolute Maximum Ratings

Parameter	Condition	Value	Unit
Supply Voltage		3.6 (max)	V _{DC}
Voltage on any Pin		-0.3 (min) V _{DD} + 0.3 (max)	V
Sound Pressure Level		160	dB
Mechanical Shock		10000	G
Vibration		Pre-MIL-STD-883 Method 2007, Test Condition B	

Measurement Method

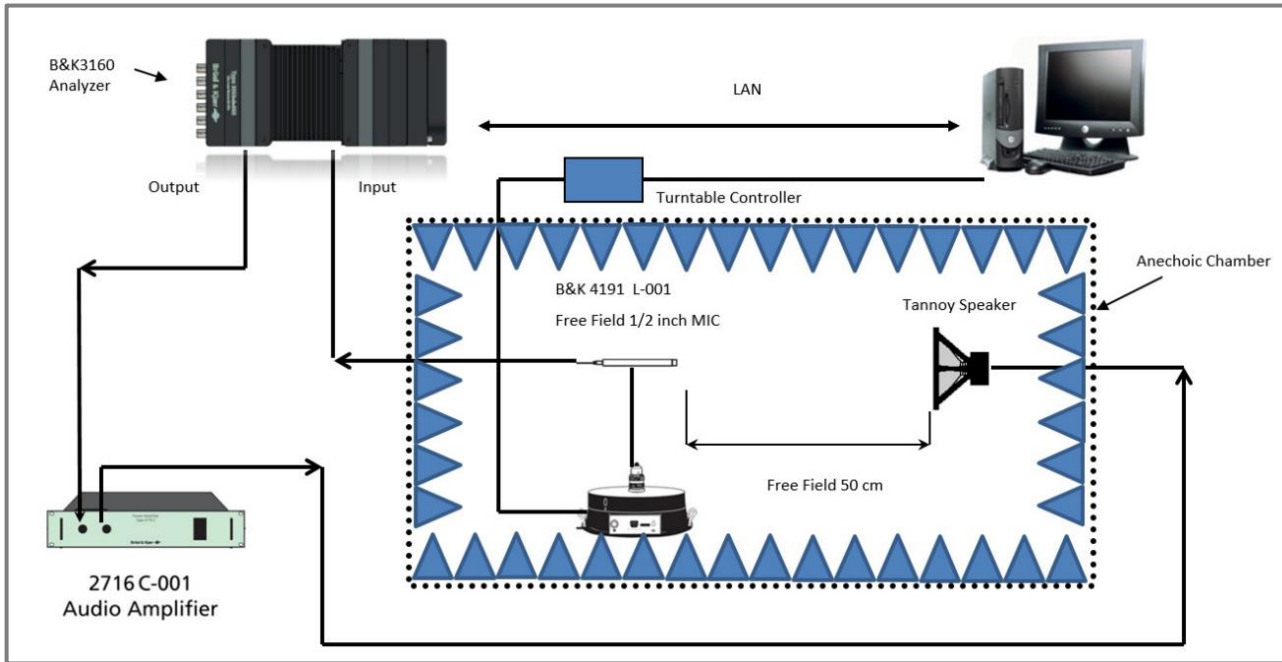

Measurement Circuit

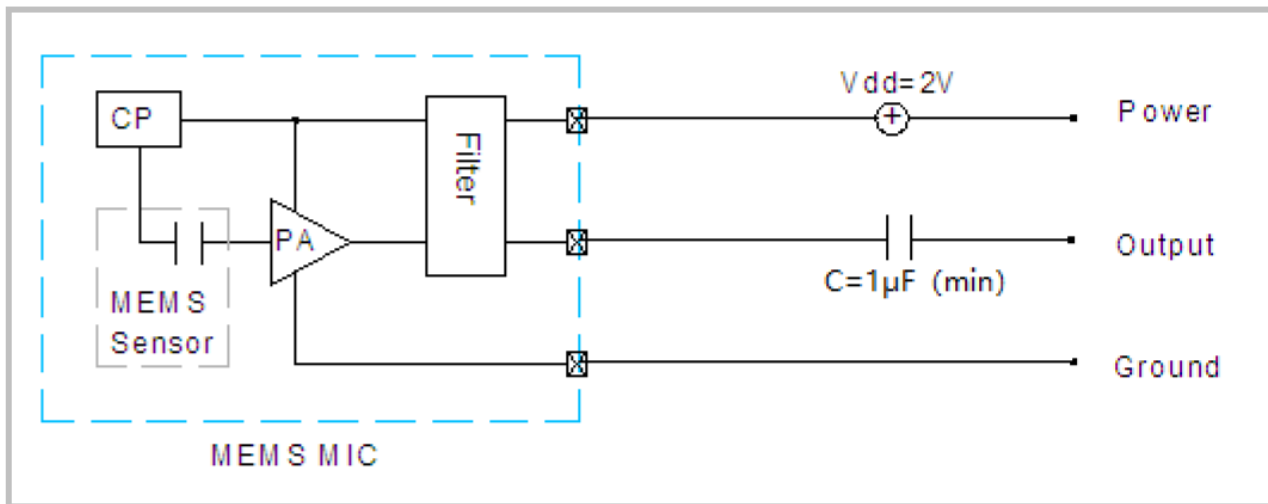

Typical Frequency Response (Normalized to 0dB at 1kHz)

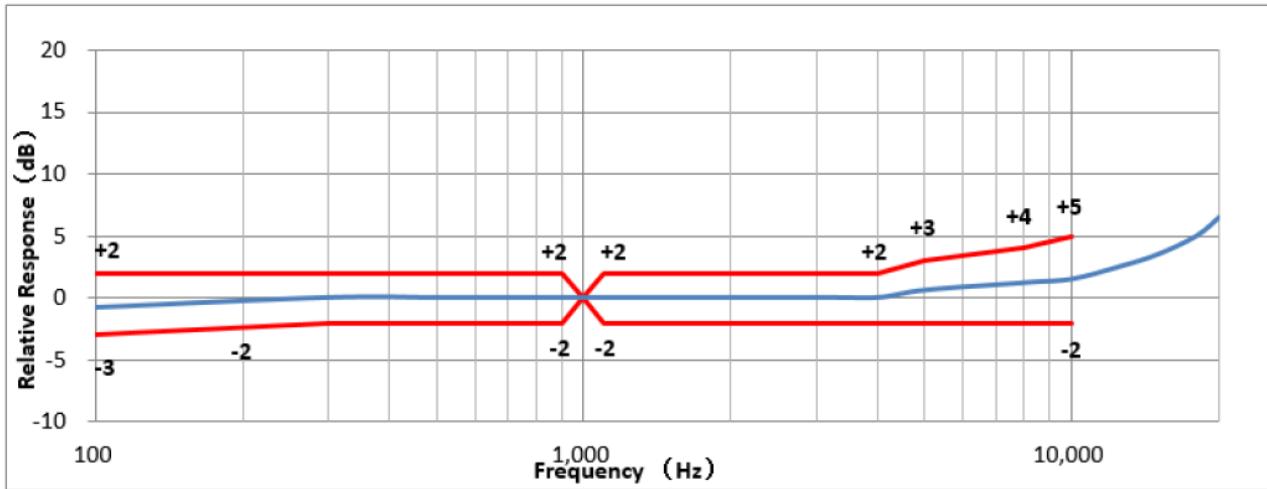

Typical THD Vs SPL

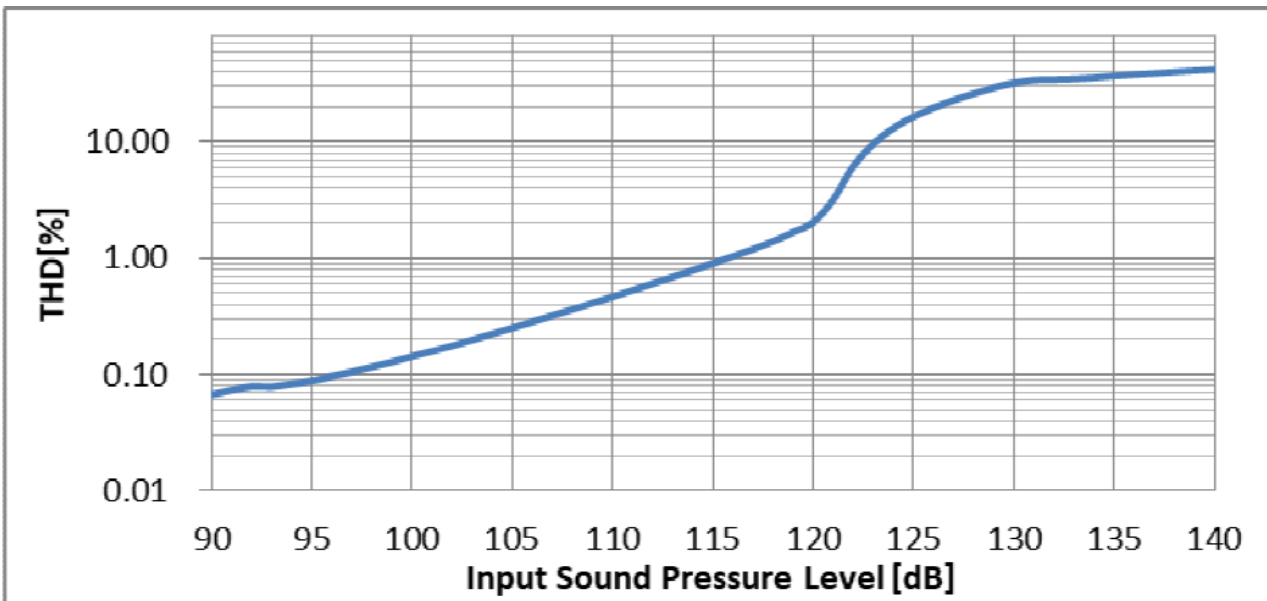

Typical THD Vs Frequency

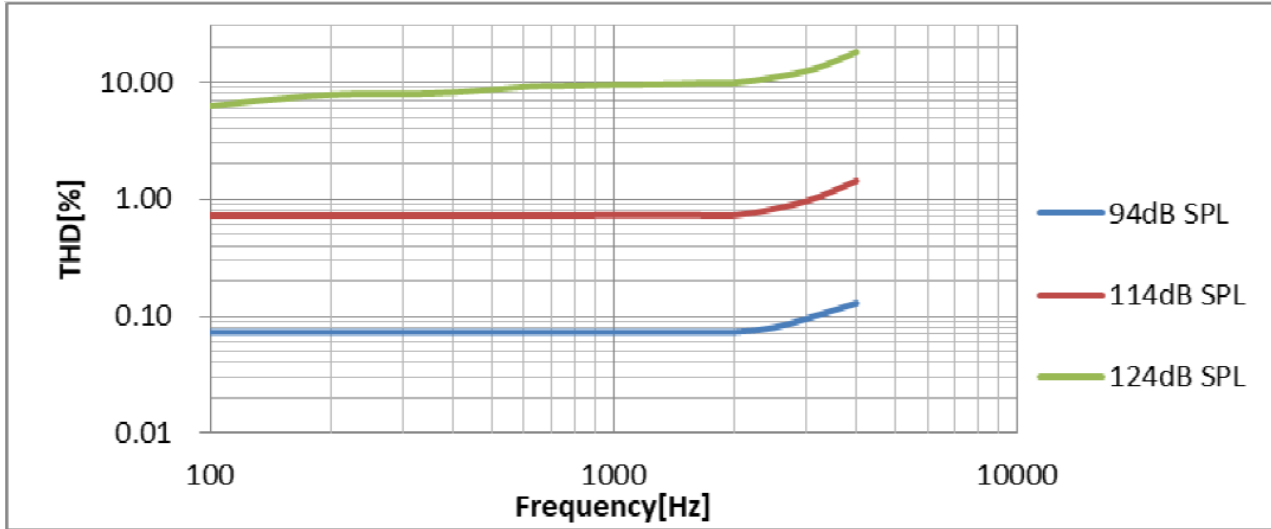

Current Consumption Vs Voltage

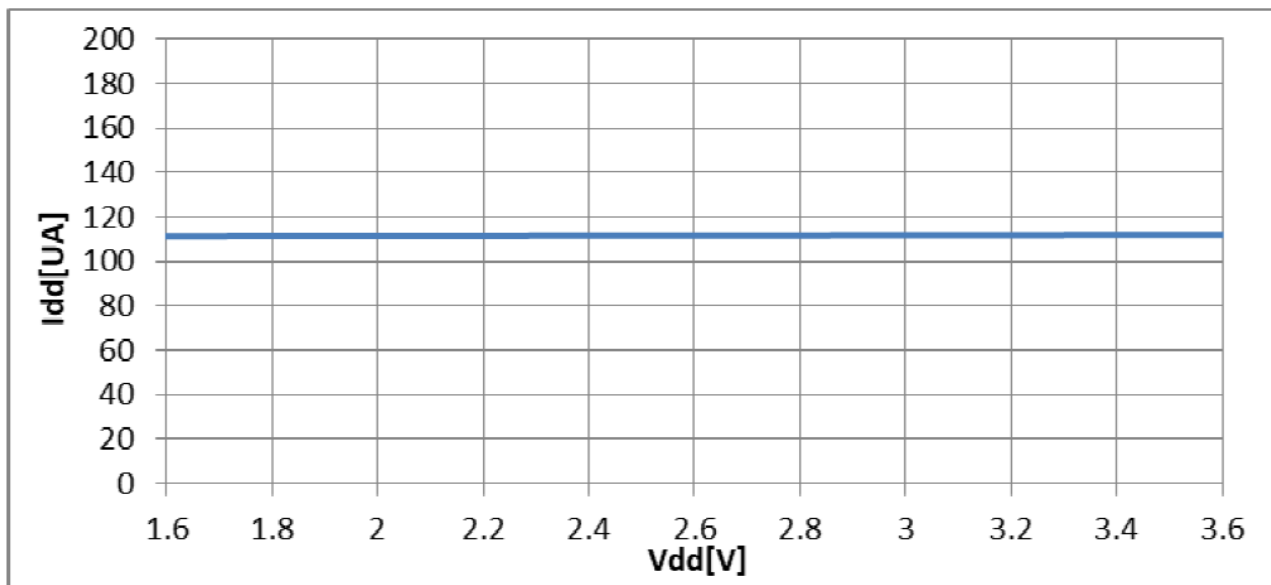

Typical Noise Floor

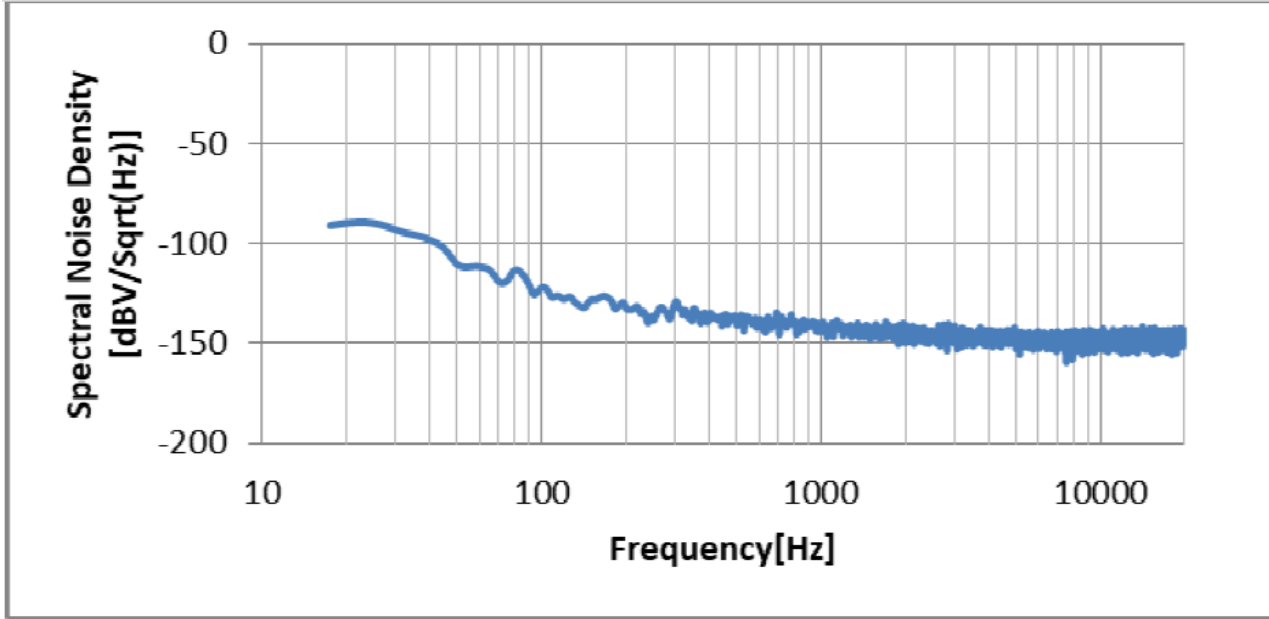

Typical PSRR Vs Frequency

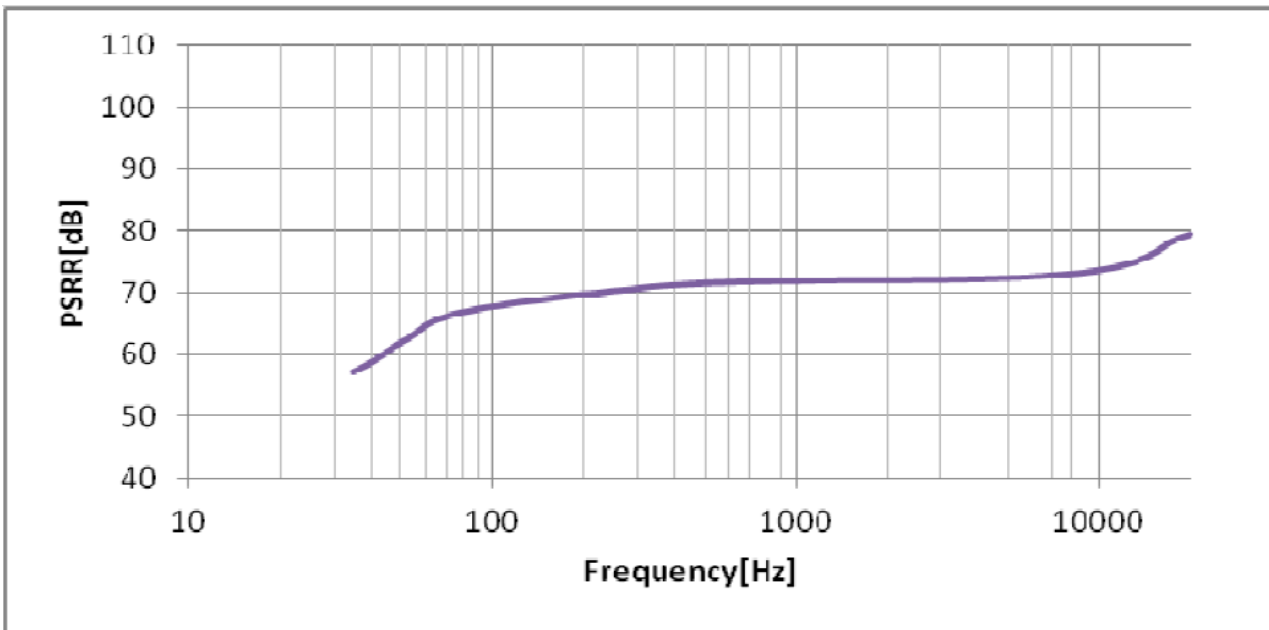

Typical Free Field Ultrasonic Response

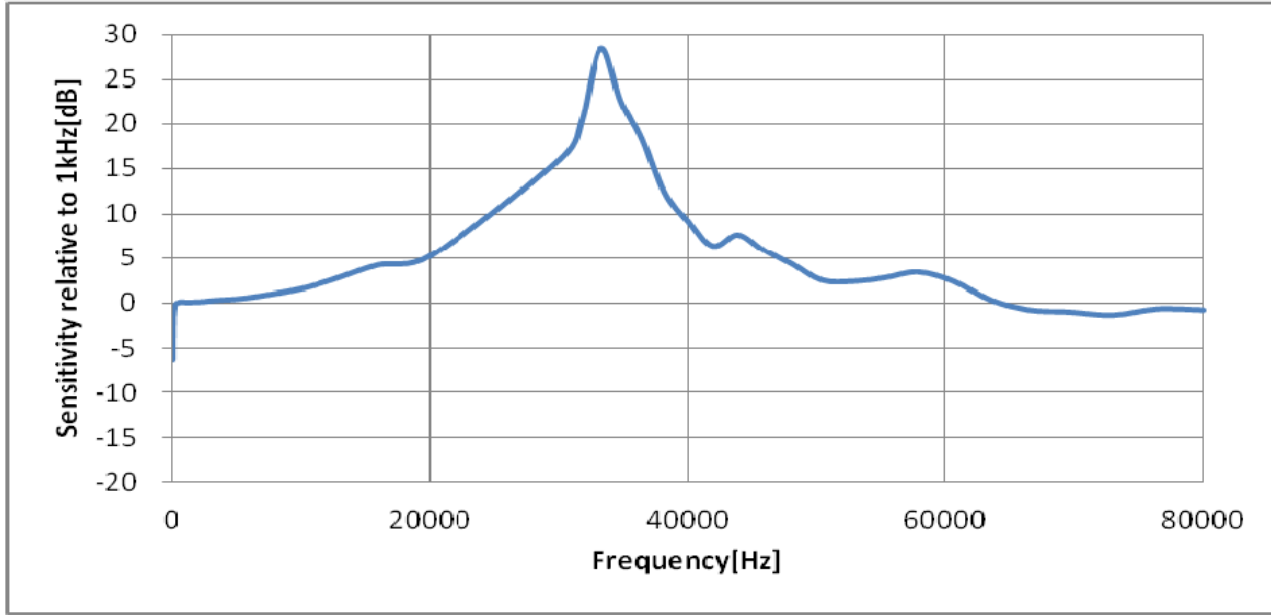

Recommended Reflow Soldering Procedure (Recommended profile, temperature ≤ 260°C, 30s maximum at peak temperature)

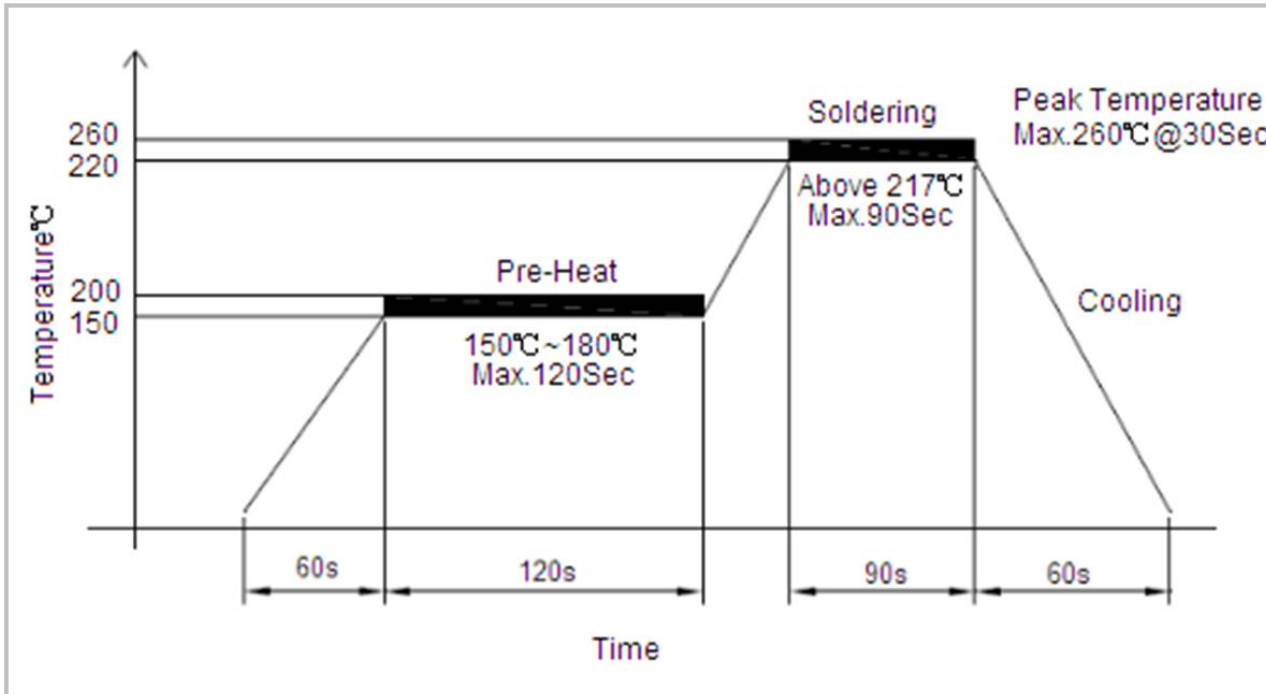

Important notes to minimize device damage

1. Do not handle the microphone with pick-and-place vacuum tools that could contact the microphone acoustic port hole.
2. Never expose the microphone's acoustic port hole to vacuum. Such exposure can damage or destroy the MEMS element.
3. Never allow air to blow into the microphone acoustic port hole. The port hole must be sealed to prevent particle contamination if a blown air-cleaning process is used.
4. A clean room environment is recommended for PCB assembly to avoid microphone contamination.
5. Do not use blown air or ultrasonic cleaning procedures on MEMS Microphones. A no-clean paste is recommended for the assembly, avoiding subsequent cleaning steps. cleaning substances can severely damage the microphone MEMS element.
6. it is recommended to cover the sound port with protective tape during PCB sawing or system assembly. This prevents blocking or partially blocking the acoustic port hole during PCB assembly.
7. Do not use excessive force to place the microphone on the PCB. Use industry standard pick and place tools to limit the mechanical force exerted on the package.

Reliability Testing (Samples under test are acclimated at $T_A = 23 \pm 2^\circ\text{C}$, R.H. = $55 \pm 10\%$ for two hours. After each test completes and corresponding recovery time (if applicable) elapses, any measured sensitivity change is $\leq \pm 3\text{dB}$, unless otherwise specified.)

Type of Test	Test Specifications
High Temperature Storage Test	1000hrs at $105 \pm 3^\circ\text{C}$ Two-hour recovery
High Temperature Operational Test	1000hrs at $105 \pm 3^\circ\text{C}$ $V_{DD} = V_{DD} (\text{max})$ Four-hour recovery
Low Temperature Storage Test	1000hrs at $-40 \pm 3^\circ\text{C}$ Two-hour recovery
Low Temperature Operational Test	1000hrs at $-40 \pm 3^\circ\text{C}$ $V_{DD} = V_{DD} (\text{max})$ Four-hour recovery
High Humidity, High Temperature Operating Test	1000hrs at $85 \pm 3^\circ\text{C}$ and 85%RH $V_{DD} = V_{DD} (\text{max})$ Twelve-hour recovery No corrosion or defatation inside the microphone
High Humidity, High Temperature Operating Test	168hrs at $65 \pm 3^\circ\text{C}$ and 95%RH $V_{DD} = V_{DD} (\text{max})$ Twelve-hour recovery No corrosion or defatation inside the microphone
Temperature-Cycle Testing	Double-case method: 15min at $-40 \pm 3^\circ\text{C}$ Followed by 15min at $125 \pm 3^\circ\text{C}$ 100 cycles, two-hour recovery
Vibration Test	Twelve minutes along the x, y, and z axis $f_{IN} = 20\text{Hz}$ to 2kHz 20G peak acceleration Two-hour recovery Less than 1dB sensitivity change
Shock Test	Height: 1.5m Fixture weight: $150 \pm 10\text{g}$ Fixture's sound hole diameter is $\geq 0.8\text{mm}$ Reference surface is marble floor Duration: four corners x four times; six faces x four times Less than 1dB sensitivity change
Tumble Test	Height: 1.0m Fixture weight: $150 \pm 10\text{g}$ Fixture's sound hole diameter is $\geq 0.8\text{mm}$ Duration: 300 cycles Less than 1dB sensitivity change
ESD Sensitivity	Measured according to MIL-STD-883G, Method 3015.7, Human Body Model (HBM) Identify ESD threshold levels indicating 3000V HBM passage.

Air Pressure Test	Air pressure = 0.3MPa Distance = 3cm Time = 10sec Air discharge port diameter exceeds microphone's acoustic port diameter
Structure Shock Test	10000G Pulse width = 0.1ms X, Y, and Z axis Three times along each axis Sensitivity changes less than 1dB

Dimensions (Dimension are in mm.)

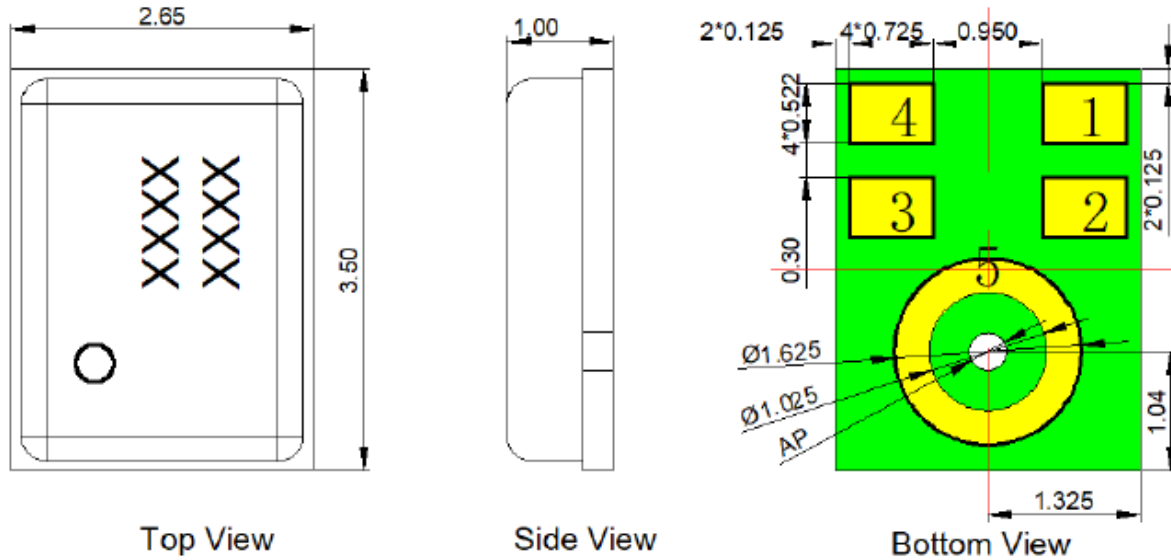

Laser Mark	Description
XXXX XXXX	Date Code

Item	Dimension	Tolerance(+/-)	Units
Length(L)	3.50	0.10	mm
Width(W)	2.65	0.10	mm
Height(H)	1.00	0.10	mm
Acoustic Port(AP)	$\varnothing 0.325$	0.05	mm

Pin #	Pin Name	Type	Description
1	Output	Signal	Output Signal
2	GND	Ground	Ground
3	GND	Ground	Ground
4	V _{DD}	Power	Power Supply
5	GND	Ground	Ground

Notes:

All dimensions are in millimeters (mm).
 Tolerance ± 0.15 mm unless otherwise specified.

Suggested Land Pattern*

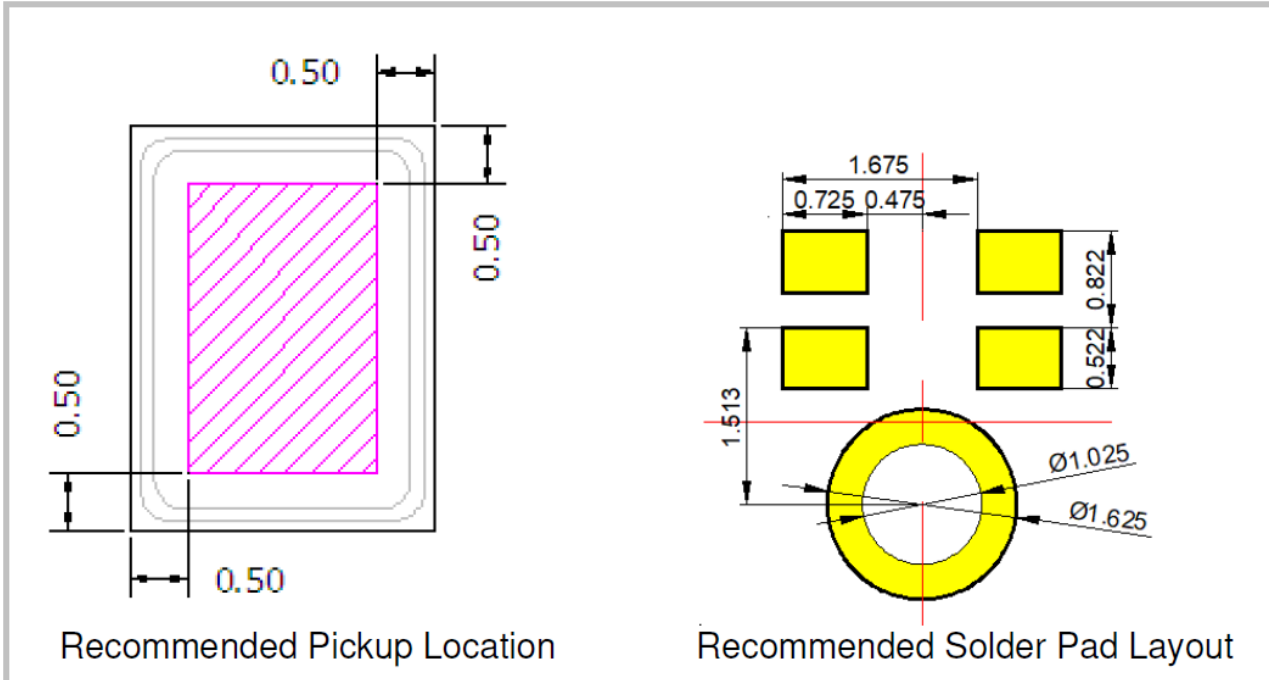

*This land pattern is advisory only and its use or adaptation is entirely voluntary. PUI Audio disclaims all liability of any kind associated with the use, application, or adaptation of this land pattern.

Packaging

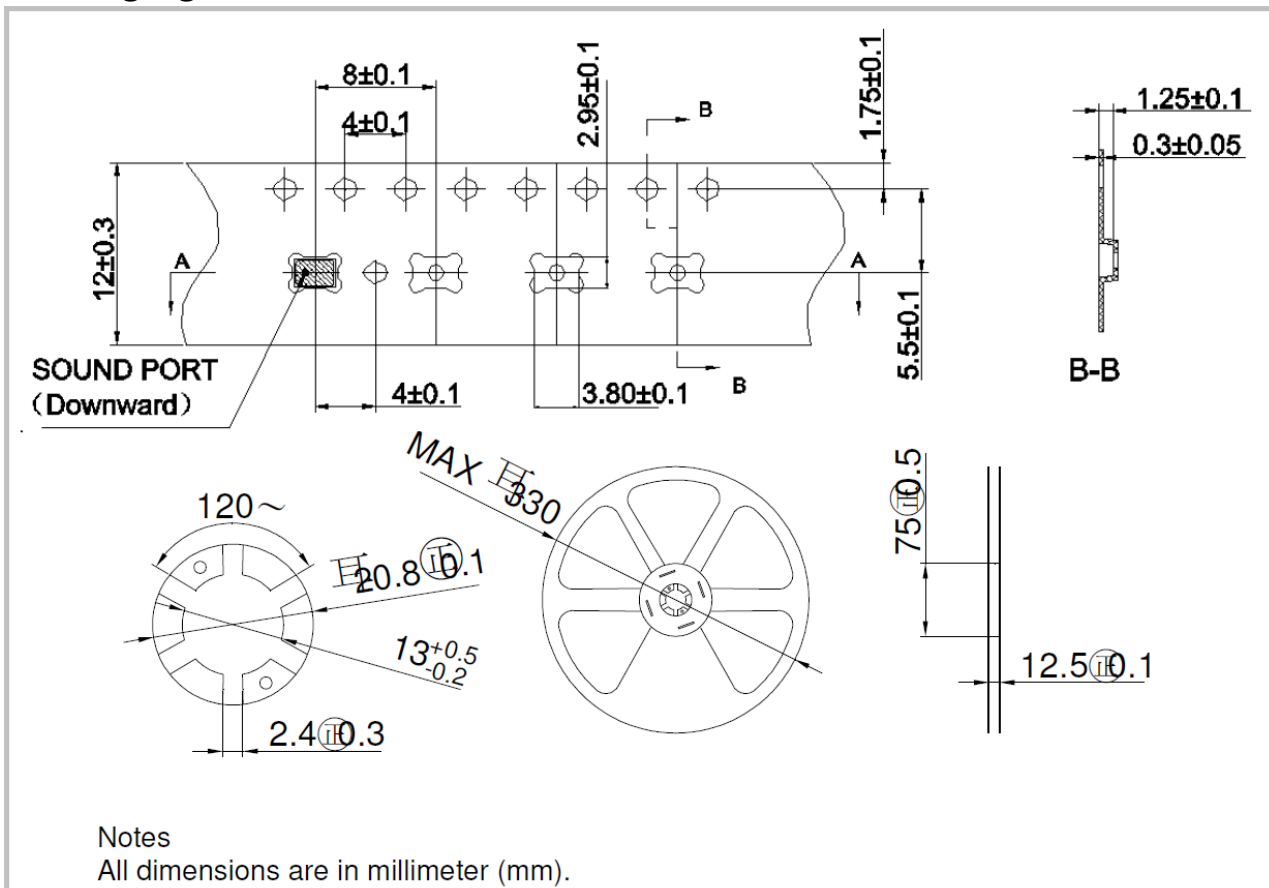

Notes
 All dimensions are in millimeter (mm).

All Dimensions are in millimeter (mm).

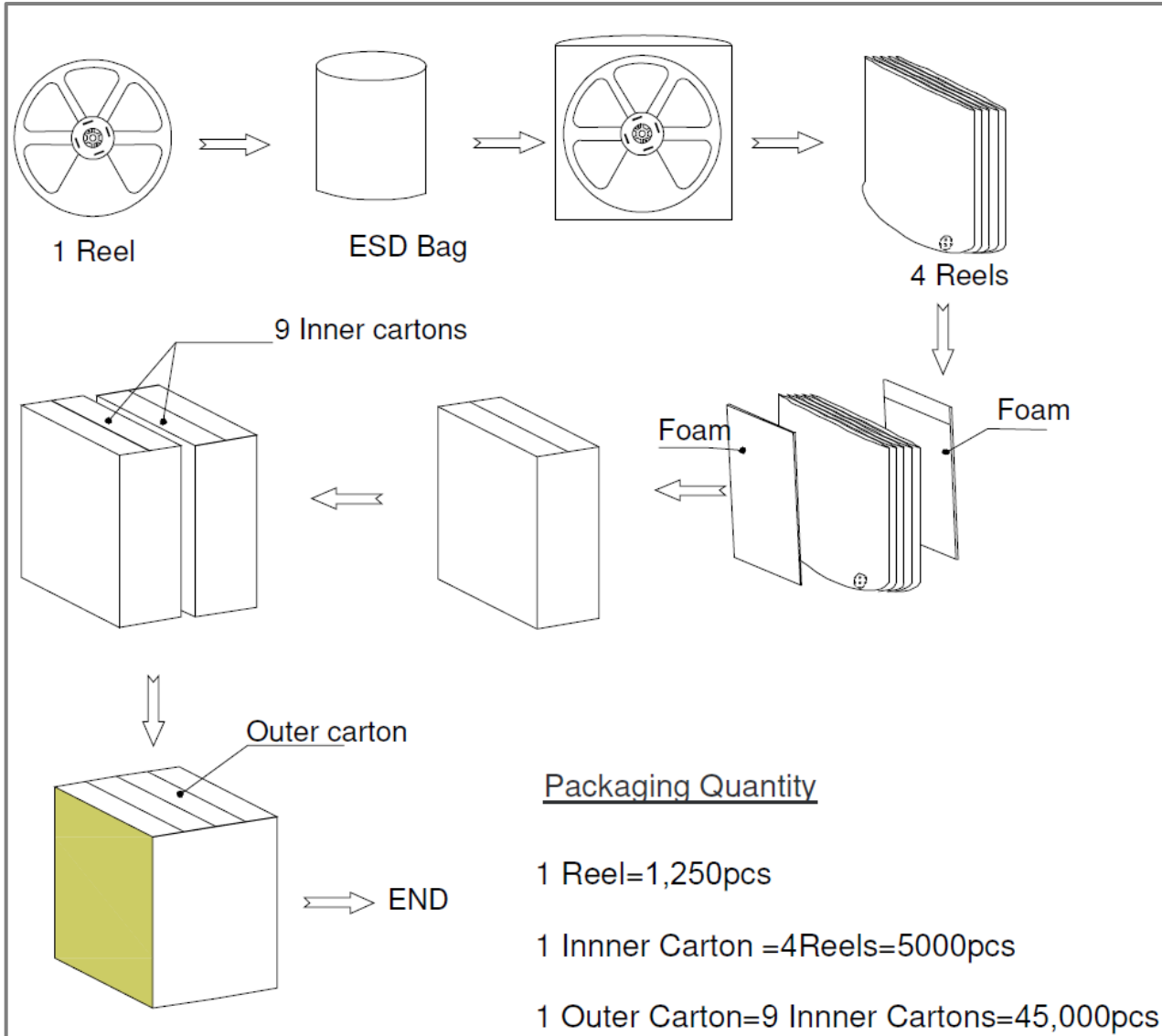

Specifications Revisions

Revision	Description	Date
A	Released from Engineering	05-9-2023

Note:

1. Unless otherwise specified:
 - A. All dimensions are in millimeters.
 - B. Default tolerances are $\pm 0.5\text{mm}$ and angles are $\pm 3^\circ$.
2. Specifications subject to change or withdrawal without notice.
3. This part is ROHS 2015/863/EU compliant.