



Data Sheet

SMT-1640-S-4-R

**Features:**

- 85 dB output with 5Vp-p 4000 Hz input
- Wide operating temperature of -40°C ~ +105°C
- Low 5 mA current draw

**Specifications**

Parameters	Values	Units
Rated Voltage	5	Vp-p
Operating Voltage Range	1 ~ 25	Vp-p
Current Draw at Rated Voltage	≤5	mA
Capacitance	16000±30%	pF
Minimum SPL @ 10cm	≥85	dBA
Resonant Frequency	4000±500	Hz
Housing Material	LCP	-
Weight	1	Grams
Acceptable Soldering Methods	Hand Solder, Reflow Solder	See below for soldering information
Environmental Compliances	RoHS	-
Storage Temperature	-40 ~ +120	°C
Operating Temperature	-40 ~ +105	°C

**Measurement Method** (5Vp-p, 4000Hz, 50% duty cycle square wave with a SPL meter at 10cm)

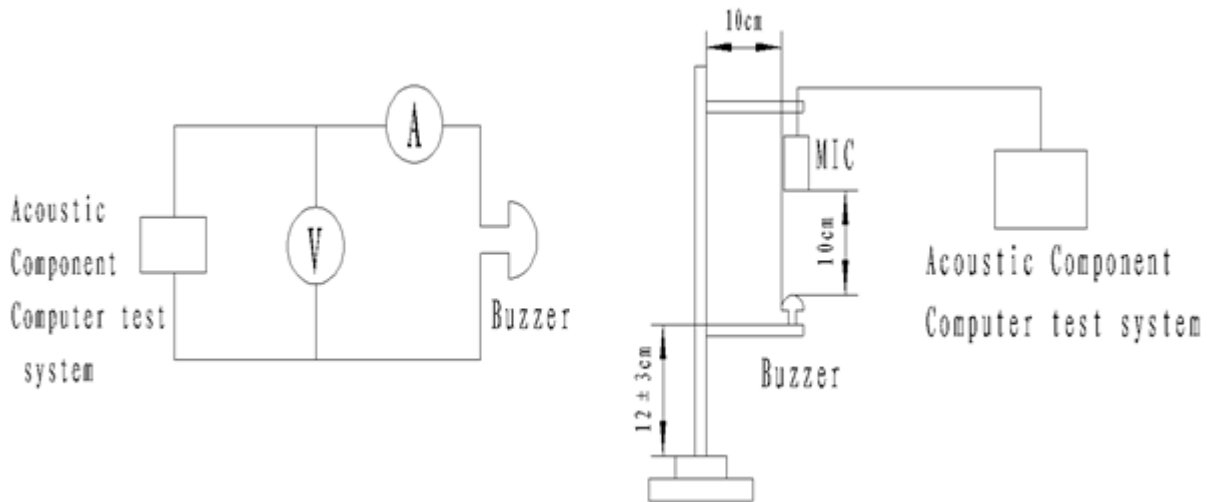

## Typical Frequency Response (3Vp-p sine-sweep with microphone spaced at 10cm)

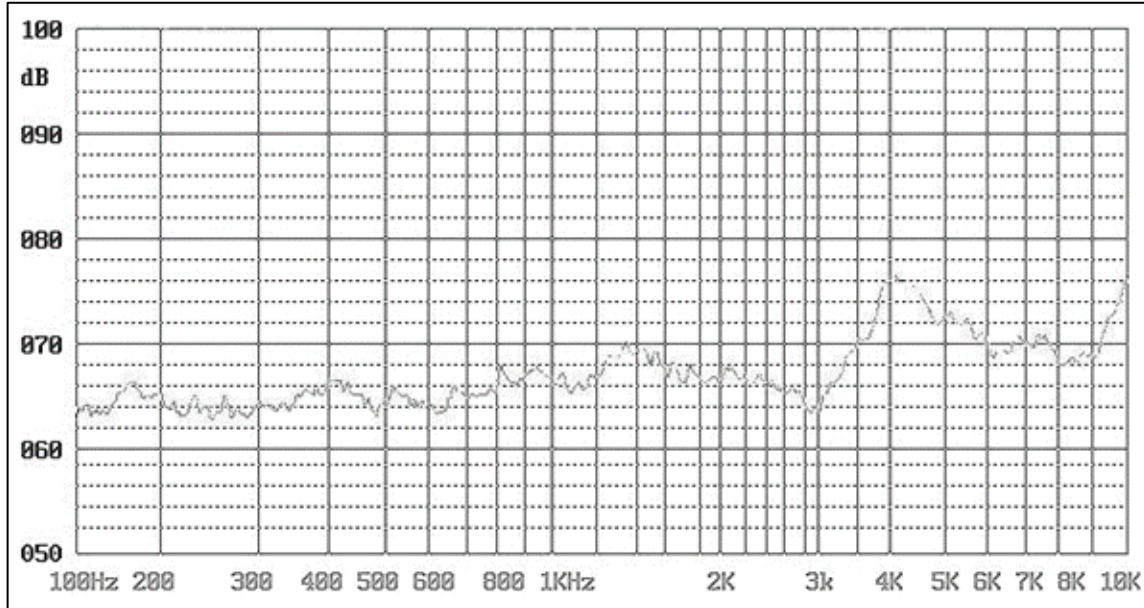

## Recommended Soldering Procedure

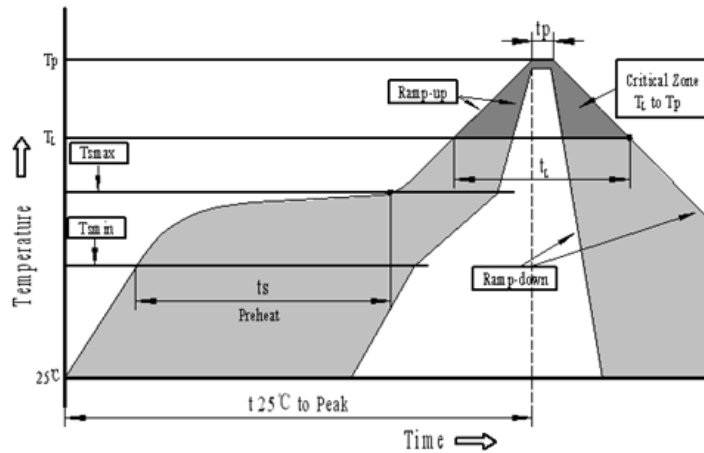

Profile Feature	Pb-Free Assembly
Average ramp-up rate(T <sub>L</sub> to T <sub>p</sub> )	3°C/second max.
Preheat	
-Temperature Min.(T <sub>smin</sub> )	150°C
-Temperature Min.(T <sub>smax</sub> )	200°C
-Temperature Min.(ts)	60~180 seconds
T <sub>smax</sub> to T <sub>L</sub>	
-Ramp-up Rate	3°C/second max.
Time maintained above:	
- Temperature(T <sub>L</sub> )	217°C
-Time(T <sub>L</sub> )	60~150 seconds
Peak temperature(T <sub>p</sub> )	250°C+0/-5°C
Time within 5°C of actual Peak temperature (tp)	6 seconds max.
Ramp-down Rate	6°C/second max.
Time 25°C to Peak Temperature	8 minutes max.
<b>We suggest the customer do the reflow soldering once.</b>	

## Reliability Testing

Type of Test	Test Specifications
High Temperature Test	The part shall be capable of withstanding a storage temperature of +120°C for 120 hours
Low Temperature Test	The part shall be capable of withstanding a storage temperature of -40°C for 120 hours
Humidity Test	40±2°C, 90~95% RH, 240 hours
Temperature Cycle Testing	Total 5 cycles, 1 cycle consisting of: -40±2°C, 30 minutes 20±5°C, 15 minutes 120±2°C, 30 minutes 20±5°C, 15 minutes
Vibration Test	The part shall be subjected to a vibration cycle of 10Hz in a period of 1 minute. Total peak amplitude shall be 1.52mm (9.3g). The vibration test shall consist of 2 hours per plane in each three mutually perpendicular planes for a total time of 6 hours.
Shock Test	Sounder shall be measured after being applied a shock (980m/s <sup>2</sup> ) for each three mutually perpendicular directions to each of 3 times by a half sine wave.
Drop Test	Dropped from 7m onto the surface of a 10mm thick wooden board. Applied to the top and side of the part

All specifications must be satisfied after the test.

## Dimensions (Units: mm Tolerance: ±0.5mm)

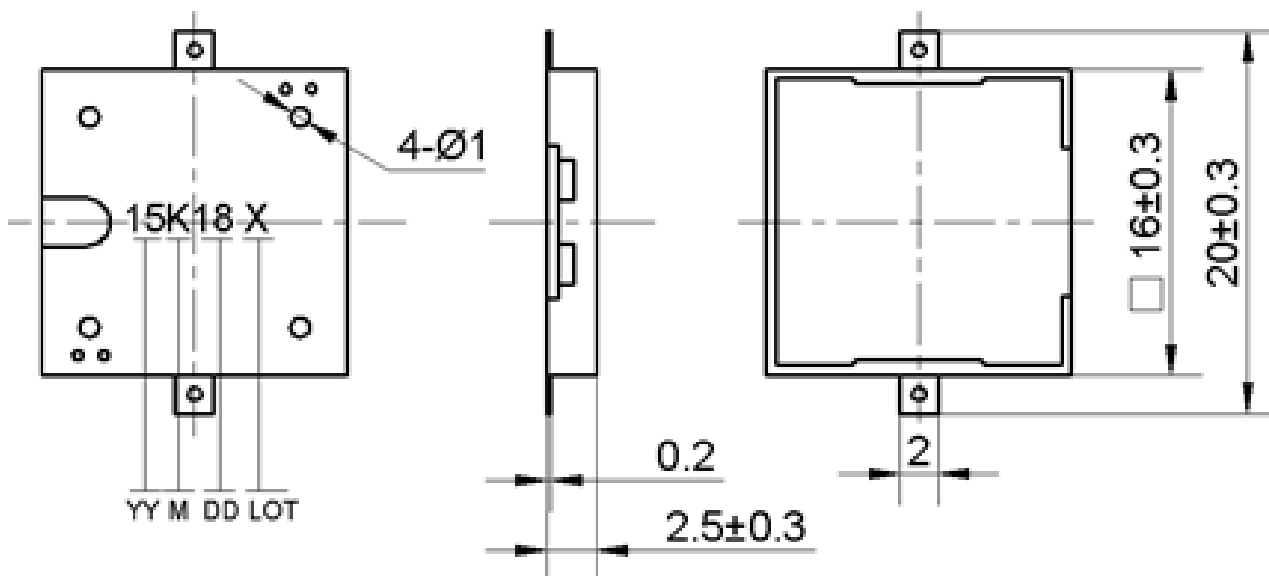

## Suggested Land Pattern\*

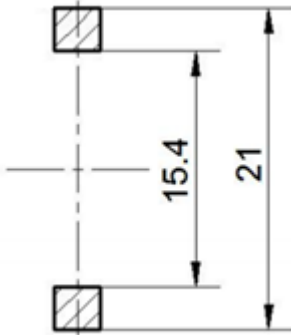

\*This land pattern is advisory only and its use or adaptation is entirely voluntary. PUI Audio disclaims all liability of any kind associated with the use, application, or adaptation of this land pattern.

## Packaging

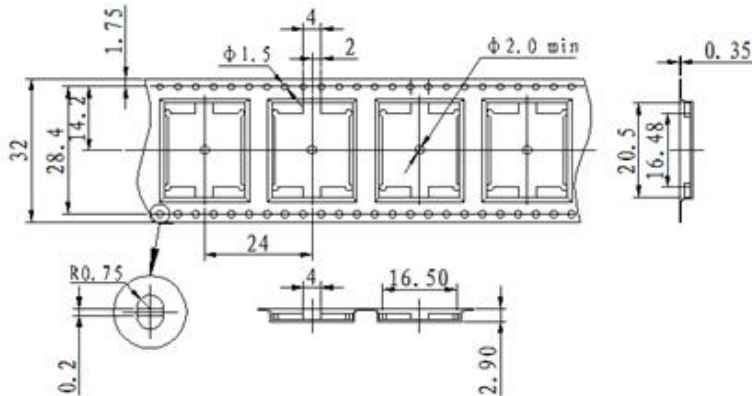

**NOTE:**

1. 10 sprocket hole pitch cumulative tolerance  $\pm 0.2$ mm.
2. All dimensions meet EIA-481-D requirements.
3. Thickness:  $0.35 \pm 0.05$ mm.
4. Component loaded per 13" reel: 800pcs.

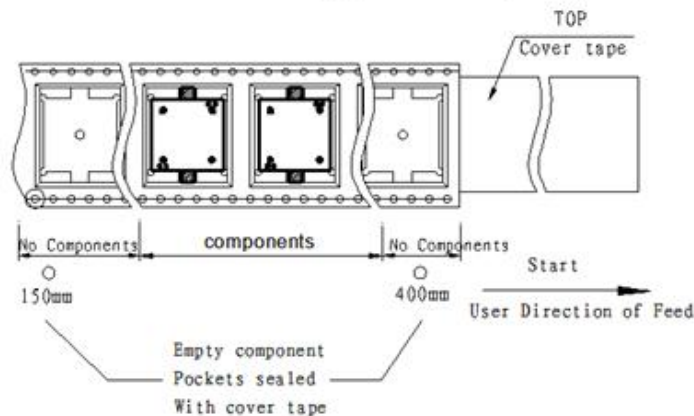
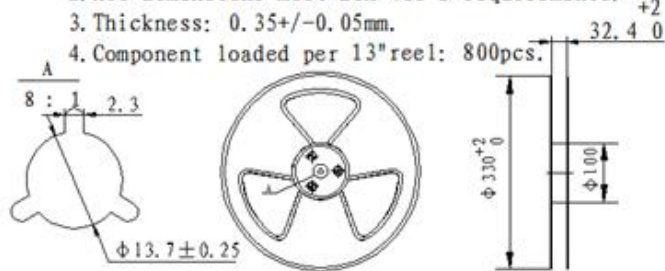

## Packaging Cont'd

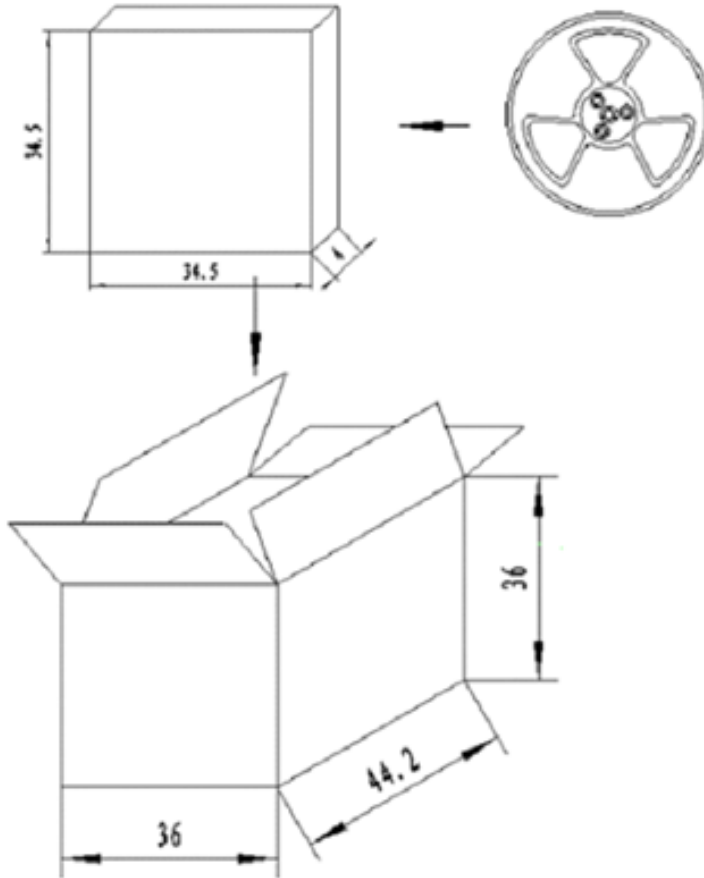

### NOTES:

- 1.800 PCS per tray
- 2.Total 10 trays per carton
- 3.Total 8000 PCS carton
- 4.Volume: $44.2 \times 36 \times 36\text{cm}$

**Specifications Revisions**

<b>Revision</b>	<b>Description</b>	<b>Date</b>
-	Released from Engineering	5/27/2020

**Note:**

1. Unless otherwise specified:
  - A. All dimensions are in millimeters.
  - B. Default tolerances are  $\pm 0.5\text{mm}$  and angles are  $\pm 3^\circ$ .
2. Specifications subject to change or withdrawal without notice.