

Key data : Dynatork 1	Metric	Imperial
Speed range	200 - 800 rpm	200 - 800 rpm
Torque at 200 rpm / 6.9 bar (100 psi)	2.79 Nm	24.7 in.lb
Torque at 800 rpm / 6.9 bar (100 psi)	1.66 Nm	14.7 in.lb
Max air consumption 800 rpm / 6.9 bar	9.7 m ³ /h	5.70 ft ³ /min
Shaft Diameter	10 mm	0.394"
Weight	1.5 kg	3.3 lb
Ports	1/8" BSP	1/8" BSP

Performance (metric)

Performance (imperial)

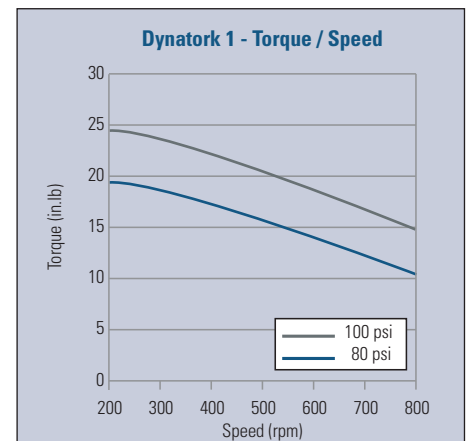
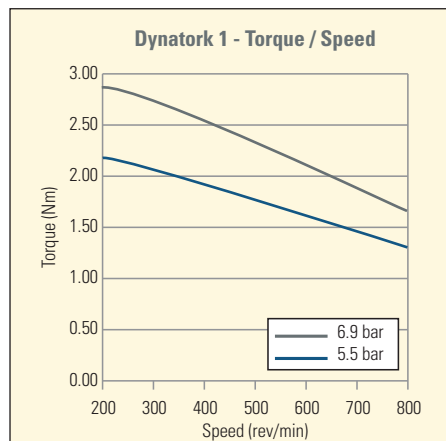
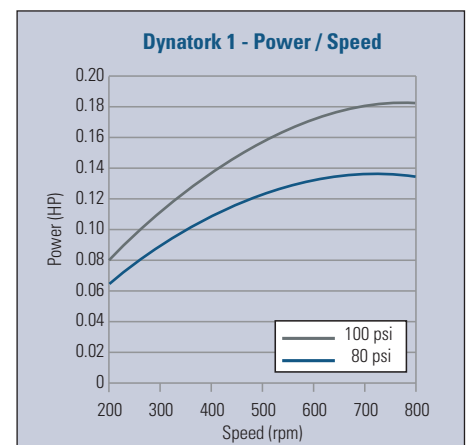
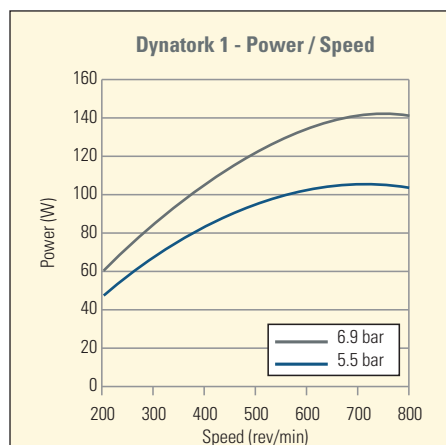

Order Codes : Dynatork 1

Item Number	Lubrication	Mounting Type
930.10.A	yes	Body
930.10.B	yes	Base
930.10.C	yes	Flange
930.15.A	non-lube	Body
930.15.B	non-lube	Base
930.15.C	non-lube	Flange

- **Lube:** for use with a lubricated air supply
- **Non-Lube:** for use with a dry, clean, non-lubricated air supply

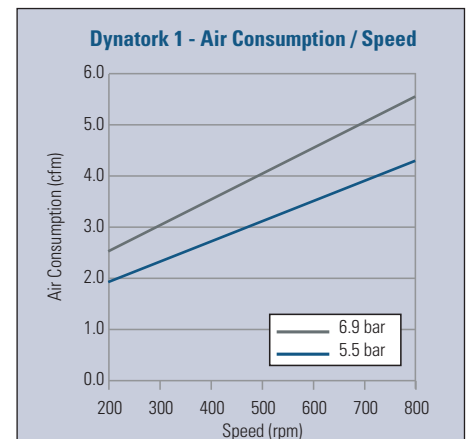
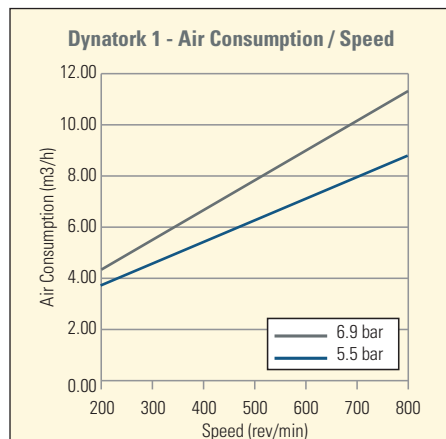

Mounting Options

Body Mounting

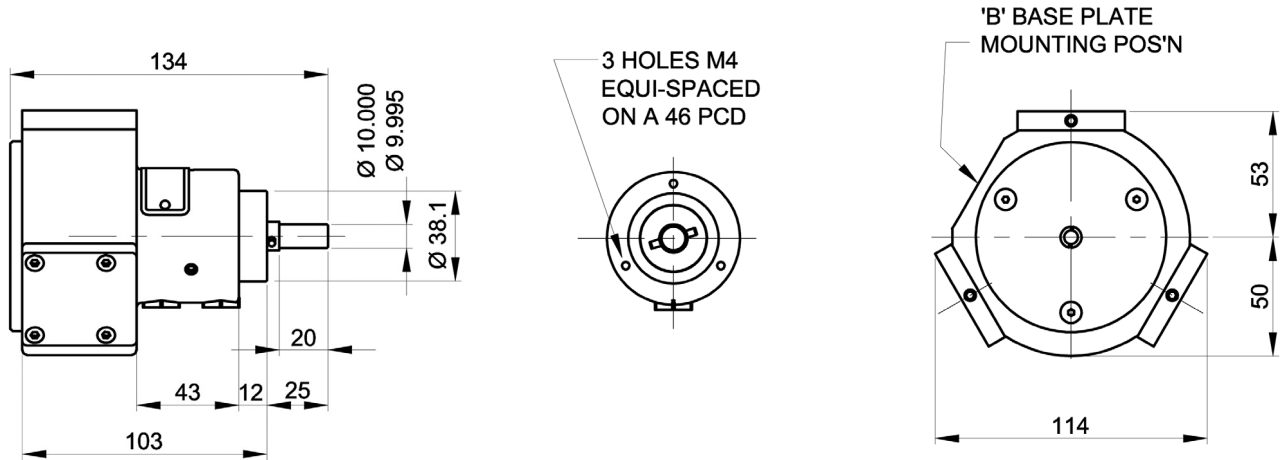

Base Mounting

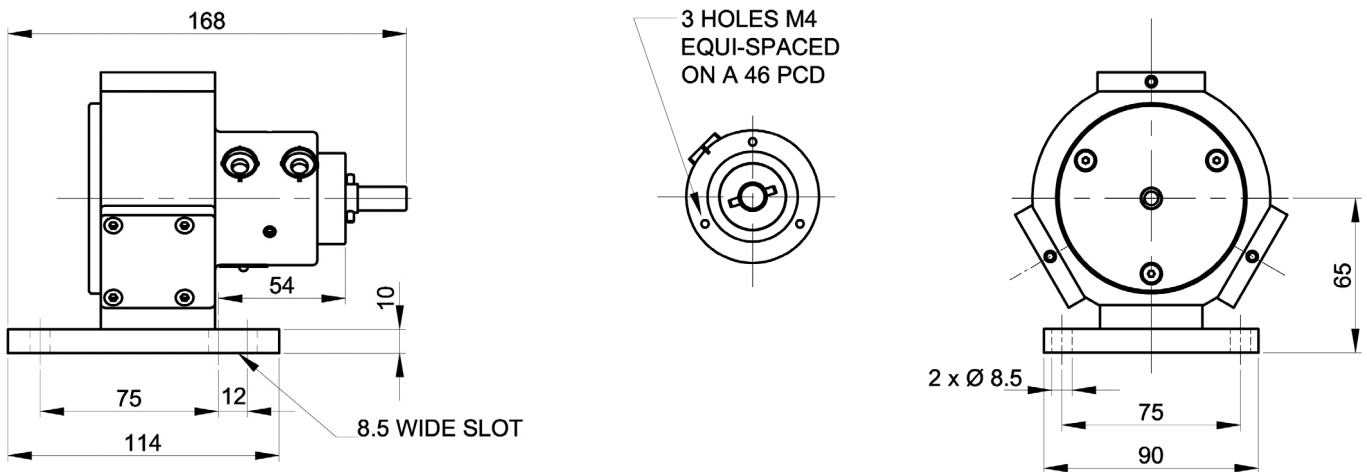

Flange Mounting

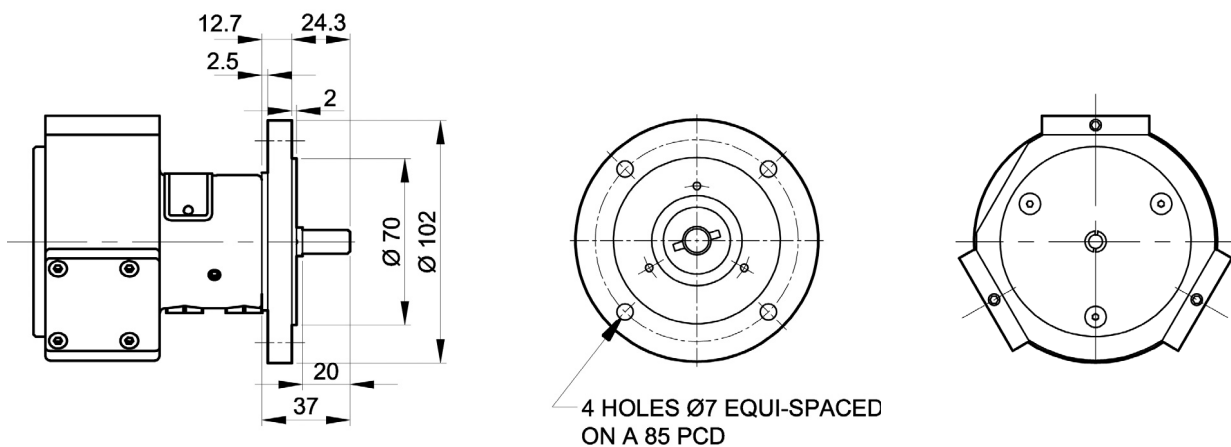

*NEMA Flanges available