

## Current Transducer FL-SDxxx series

$I_{PN} = 12000 \text{ A} \dots 28000 \text{ A}$

Ref: FL 12000-SDxxx, FL 16000-SDxxx, FL 20000-SDxxx, FL 24000-SDxxx,  
FL 28000-SDxxx

For the electronic measurement of current: DC, AC, pulsed..., with galvanic separation between the primary and the secondary circuit.



Provisional



### Features

- Hall effect Open Loop Coreless Integral current transducer
- Uni- or Bi-polar <sup>1)</sup> measurement of primary current up to 42 kA
- Instantaneous 0-5 V voltage output
- Power supply +12 or +24 V DC
- Galvanic separation between primary and secondary circuit
- Factory calibrated.

### Advantages

- Wide measurement range
- 2 aperture widths: 200 and 300 mm
- No magnetic offset
- Low consumption and low losses
- Wide range of rectangular busbar dimensions
- Light weight design
- M12 field connector.

### Applications

- Wind turbine power converter
- Electrolyser
- High power drives.

### Standards

- IEC 62477-1: 2022
- IEC 61800-5-1: 2022
- IEC 62109-1: 2010
- IEC 61010-1: 2010
- EN 50155: 2021
- IEC 61992-7-2: 2006
- UL 61010-1: 3ED 2022.

### Application Domains

- Industrial
- Trackside.

Note: <sup>1)</sup> see references on [page 11](#).

## Safety



Caution

If the device is used in a way that is not specified by the manufacturer, the protection provided by the device may be compromised. Always inspect the electronics unit and connecting cable before using this product and do not use it if damaged. Mounting assembly shall guarantee the maximum primary conductor temperature, fulfill clearance and creepage distance, minimize electric and magnetic coupling, and unless otherwise specified can be mounted in any orientation.



Caution, risk of electrical shock

This transducer must be used in limited-energy secondary circuits SELV according to IEC 61010-1, in electric/electronic equipment with respect to applicable standards and safety requirements in accordance with the manufacturer's operating specifications.

Use caution during installation and use of this product; certain parts of the module can carry hazardous voltages and high currents (e.g. power supply, primary conductor).

Ignoring this warning can lead to injury and and/or cause serious damage.

De-energize all circuits and hazardous live parts before installing the product.

All installations, maintenance, servicing operations and use must be carried out by trained and qualified personnel practicing applicable safety precautions.

This transducer is a build-in device, whose hazardous live parts must be inaccessible after installation.

This transducer must be mounted in a suitable end-enclosure.

Main supply must be able to be disconnected.

Never connect or disconnect the external power supply while the primary circuit is connected to live parts.

Always wear protective clothing and gloves if hazardous live parts are present in the installation where the measurement is carried out.

This transducer is a built-in device, not intended to be cleaned with any product. Nevertheless if the user must implement cleaning or washing process, validation of the cleaning program has to be done by himself.

Do not dispose of this product as unsorted municipal waste.

Contact a qualified recycler for disposal.

**Absolute maximum ratings**

Parameter	Symbol	Unit	Value
Maximum supply voltage (not destructive)	$\pm U_{C,max}$	V	-0.3 ... 32 V DC
Maximum primary conductor temperature	$T_{B,max}$	°C	105
Electrostatic discharge voltage (HBM - Human Body Model)	$U_{ESD,HBM}$	kV	2

Stresses above these ratings may cause permanent damage.

Exposure to absolute maximum ratings for extended periods may degrade reliability.

**Insulation coordination**

Parameter	Symbol	Unit	Value	Comment
RMS voltage for AC insulation test, 50 Hz, 1 min	$U_d$	kV	12	
Impulse withstand voltage 1.2/50 $\mu$ s	$U_{Ni}$	kV	44	Target, TBC
RMS voltage for AC insulation routine test, 50 Hz, 2"		kV	5.3	Industry application <sup>1)</sup>
RMS voltage for AC insulation routine test, 50 Hz, 5"		kV	18.5	Traction application <sup>1)</sup>
Partial discharge RMS type test voltage ( $q_m < 10$ pC)	$U_t$	V	2480	Primary/Secondary Industry application <sup>1) 2)</sup>
Partial discharge RMS type test voltage ( $q_m < 10$ pC)	$U_t$	V	4840	Primary/Secondary Traction application <sup>1) 2)</sup>
Minimum clearance (pri. - sec.)	$d_{Cl}$	mm	> 72	Shortest distance through air
Minimum creepage distance (pri. - sec.)	$d_{Cp}$	mm	> 100	Shortest path along device body
Case material	-	-	V0	According to UL 94
Comparative tracking index	$CTI$		600	
Application example Industry Working voltage		V	1500	Reinforced insulation non-uniform According to: IEC 61800-5-1, CAT III PD2 IEC 61010-1, CAT IV PD3 IEC 62477-1, CAT IV PD3
Application example Trackside/Traction Nominal voltage Rated insulation voltage	$U_N$ $U_{Nm}$	V	3000 3600/3700	Reinforced insulation non-uniform According to: IEC 62497-1, CAT III PD3

**Environmental and mechanical characteristics**

Parameter	Symbol	Unit	Min	Typ	Max	Comment
Ambient operating temperature	$T_A$	°C	-40		+85	
Ambient storage temperature	$T_{A,st}$	°C	-40		+90	
Mass	$m$	g		1180 1320		- SDxlx200 - SDxlx300

**Notes:** <sup>1)</sup> See reference table on [page 11](#)

<sup>2)</sup> Guaranteed with a centered busbar of 200 (300) x 100 mm maximum dimension with an edge chamfer of 1.5 mm or any other shape and layout providing a minimum clearance of 3 mm between the bare metal and the inner wall of the transducer.

**Electrical data FL 12000-SDxx200**

 At  $T_A = 25\text{ °C}$ ,  $U_C = +24\text{ V}$ ,  $R_L = 10\text{ k}\Omega$ , unless otherwise noted (see Min, Max, typ, definition paragraph in [page 9](#)).

Parameter		Symbol	Unit	Min	Typ	Max	Comment
Primary nominal current		$I_{PN}$	A		12000		See <sup>1)</sup>
Primary current, measuring range		$I_{PM}$	A	-18000 0		18000 18000	SDx version SDUx version
Supply voltage		$U_C$	V	10		28	See <sup>2)</sup>
Current consumption	SDxx200	$I_C$	mA		200 100	240 120	@ $U_C = 12\text{ V DC}$ @ $U_C = 24\text{ V DC}$
	SDxx300				240 120	280 140	@ $U_C = 12\text{ V DC}$ @ $U_C = 24\text{ V DC}$
Output reference voltage		$U_{ref} - 0\text{ V}$	V	2.48 2.48	2.5 2.5	2.55 2.53	@ $U_C = 12\text{ V DC}$ @ $U_C = 24\text{ V DC}$
$U_{ref}$ output resistance		$R_{ref}$	$\Omega$	16	25	38	
$U_{out}$ output resistance		$R_{out}$	$\Omega$		10		
Output voltage range <sup>3)</sup>		$U_{out} - U_{ref}$	V	-2		2	SDx version: $U_{out} - U_{ref} = 0\text{ V} @ I_P = 0$ SDUx version: $U_{out} - U_{ref} = -2\text{ V} @ I_P = 0$
Load capacitance		$C_L$	nF		10		
Electrical offset current referred to primary		$I_{OE}$	A	-27		27	
Nominal sensitivity		$S_N$	mV/A		0.111 0.222		SDx version SDUx version
Magnetic offset current (@ $I_{PN}$ ) referred to primary		$I_{OM}$	A		none		No magnetic core inside, OLCI technology
Sensitivity error @ $I_{PN}$		$\epsilon_S$	%	-0.15		0.15	Factory adjustment
Linearity error 0 ... $I_{PM}$		$\epsilon_L$	% of $I_{PM}$	-0.35		0.35	
Temperature coefficient of $U_{ref}$		$T_{CU_{ref}}$	ppm/K	-80		80	-40 °C ... +85 °C
Temperature coefficient of $I_{OE}$		$T_{CI_{OE}}$	A/K	-1.4		1.4	-40 °C ... +85 °C
Temperature coefficient of $S$		$T_{CS}$	ppm/K	-120		120	-40 °C ... +85 °C
Sum of sensitivity & Linearity error 0 ... $I_{PM}$		$\epsilon_{SL}$	% of $I_{PM}$	-0.5		0.5	Primary busbar centered No return busbar considered <sup>4)</sup>
Total error @ 25 °C @ $I_P = 0$ @ $I_P = \pm I_{PM}$		$\epsilon_{tot}$	% of $I_{PM}$	-0.15 -0.65		0.15 0.65	Primary busbar centered No return busbar considered <sup>4)</sup>
Total error @ -40 °C @ $I_P = 0$ @ $I_P = \pm I_{PM}$		$\epsilon_{tot}$	% of $I_{PM}$	-0.54 -1.25		0.54 1.25	Primary busbar centered No return busbar considered <sup>4)</sup>
Total error @ 85 °C @ $I_P = 0$ @ $I_P = \pm I_{PM}$		$\epsilon_{tot}$	% of $I_{PM}$	-0.50 -1.19		0.50 1.19	Primary busbar centered No return busbar considered <sup>4)</sup>
Delay time @ 10 % of the final output value $I_{PN}$ step		$t_{D10}$	$\mu\text{s}$			2.5	@ 100 A/ $\mu\text{s}$
Delay time @ 90 % of the final output value $I_{PN}$ step		$t_{D90}$	$\mu\text{s}$			2.5	@ 100 A/ $\mu\text{s}$
Frequency bandwidth (-3 dB)		$BW$	kHz		100		
RMS noise current spectral density referred to primary 100 Hz ... 100 kHz 100 kHz ... 1 MHz		$i_{no}$	$\text{mA}/\sqrt{\text{Hz}}$		TBD		
Peak to peak noise current referred to primary: up to 10 kHz up to 100 kHz up to 1 MHz		$I_{no pp}$	mA		TBD		

- Notes:**
- <sup>1)</sup> This low power coreless transducer may accept up to  $I_{Pmax}$  permanent current; at the only condition of respecting the maximum primary conductor temperature (105 °C)
  - <sup>2)</sup> Above 28 V, accuracy performance may change irremediably
  - <sup>3)</sup> Rounded, actual value is obtained by the following formula:  $\pm I_{PM} \times S_N$
  - <sup>4)</sup> See [page 10](#) typical influence of the return busbar regarding its position.

**Electrical data FL 16000-SDxx200**

 At  $T_A = 25\text{ °C}$ ,  $U_C = +24\text{ V}$ ,  $R_L = 10\text{ k}\Omega$ , unless otherwise noted (see Min, Max, typ, definition paragraph in [page 9](#)).

Parameter		Symbol	Unit	Min	Typ	Max	Comment
Primary nominal current		$I_{PN}$	A		16000		See <sup>1)</sup>
Primary current, measuring range		$I_{PM}$	A	-24000 0		24000 24000	SDx version SDUx version
Supply voltage		$U_C$	V	10		28	See <sup>2)</sup>
Current consumption	SDxx200	$I_C$	mA		200 100	240 120	@ $U_C = 12\text{ V DC}$ @ $U_C = 24\text{ V DC}$
	SDxx300				240 120	280 140	@ $U_C = 12\text{ V DC}$ @ $U_C = 24\text{ V DC}$
Output reference voltage		$U_{ref} - 0\text{ V}$	V	2.48 2.48	2.5 2.5	2.55 2.53	@ $U_C = 12\text{ V DC}$ @ $U_C = 24\text{ V DC}$
$U_{ref}$ output resistance		$R_{ref}$	$\Omega$	16	25	38	
$U_{out}$ output resistance		$R_{out}$	$\Omega$		10		
Output voltage range <sup>3)</sup>		$U_{out} - U_{ref}$	V	-2		2	SDx version: $U_{out} - U_{ref} = 0\text{ V @ } I_P = 0$ SDUx version: $U_{out} - U_{ref} = -2\text{ V @ } I_P = 0$
Load capacitance		$C_L$	nF		10		
Electrical offset current referred to primary		$I_{OE}$	A	-36		36	
Nominal sensitivity		$S_N$	mV/A		0.083 0.167		SDx version SDUx version
Magnetic offset current (@ $I_{PN}$ ) referred to primary		$I_{OM}$	A		none		No magnetic core inside, OLCI technology
Sensitivity error @ $I_{PN}$		$\epsilon_S$	%	-0.15		0.15	Factory adjustment
Linearity error 0 ... $I_{PM}$		$\epsilon_L$	% of $I_{PM}$	-0.35		0.35	
Temperature coefficient of $U_{ref}$		$TCU_{ref}$	ppm/K	-80		80	-40 °C ... +85 °C
Temperature coefficient of $I_{OE}$		$TCl_{OE}$	A/K	-1.9		1.9	-40 °C ... +85 °C
Temperature coefficient of $S$		$TCS$	ppm/K	-120		120	-40 °C ... +85 °C
Sum of sensitivity & Linearity error 0 ... $I_{PM}$		$\epsilon_{SL}$	% of $I_{PM}$	-0.5		0.5	Primary busbar centered No return busbar considered <sup>4)</sup>
Total error @ 25 °C @ $I_P = 0$ @ $I_P = \pm I_{PM}$		$\epsilon_{tot}$	% of $I_{PM}$	-0.15 -0.65		0.15 0.65	Primary busbar centered No return busbar considered <sup>4)</sup>
Total error @ -40 °C @ $I_P = 0$ @ $I_P = \pm I_{PM}$		$\epsilon_{tot}$	% of $I_{PM}$	-0.54 -1.25		0.54 1.25	Primary busbar centered No return busbar considered <sup>4)</sup>
Total error @ 85 °C @ $I_P = 0$ @ $I_P = \pm I_{PM}$		$\epsilon_{tot}$	% of $I_{PM}$	-0.50 -1.19		0.50 1.19	Primary busbar centered No return busbar considered <sup>4)</sup>
Delay time @ 10 % of the final output value $I_{PN}$ step		$t_{D10}$	$\mu\text{s}$			2.5	@ 100 A/ $\mu\text{s}$
Delay time @ 90 % of the final output value $I_{PN}$ step		$t_{D90}$	$\mu\text{s}$			2.5	@ 100 A/ $\mu\text{s}$
Frequency bandwidth (-3 dB)		$BW$	kHz		100		
RMS noise current spectral density referred to primary 100 Hz ... 100 kHz 100 kHz ... 1 MHz		$i_{no}$	$\text{mA}/\sqrt{\text{Hz}}$		TBD		
Peak to peak noise current referred to primary: up to 10 kHz up to 100 kHz up to 1 MHz		$I_{no\text{pp}}$	mA		TBD		

- Notes:**
- <sup>1)</sup> This low power coreless transducer may accept up to  $I_{P\text{max}}$  permanent current; at the only condition of respecting the maximum primary conductor temperature (105 °C)
  - <sup>2)</sup> Above 28 V, accuracy performance may change irremediably
  - <sup>3)</sup> Rounded, actual value is obtained by the following formula:  $\pm I_{PM} \times S_N$
  - <sup>4)</sup> See [page 10](#) typical influence of the return busbar regarding its position.

**Electrical data FL 20000-SDxx200**

 At  $T_A = 25\text{ °C}$ ,  $U_C = +24\text{ V}$ ,  $R_L = 10\text{ k}\Omega$ , unless otherwise noted (see Min, Max, typ, definition paragraph in [page 9](#)).

Parameter		Symbol	Unit	Min	Typ	Max	Comment
Primary nominal current		$I_{PN}$	A		20000		See <sup>1)</sup>
Primary current, measuring range		$I_{PM}$	A	-30000 0		30000 30000	SDx version SDUx version
Supply voltage		$U_C$	V	10		28	See <sup>2)</sup>
Current consumption	SDxx200	$I_C$	mA		200 100	240 120	@ $U_C = 12\text{ V DC}$ @ $U_C = 24\text{ V DC}$
	SDxx300				240 120	280 140	@ $U_C = 12\text{ V DC}$ @ $U_C = 24\text{ V DC}$
Output reference voltage		$U_{ref} - 0\text{ V}$	V	2.48 2.48	2.5 2.5	2.55 2.53	@ $U_C = 12\text{ V DC}$ @ $U_C = 24\text{ V DC}$
$U_{ref}$ output resistance		$R_{ref}$	$\Omega$	16	25	38	
$U_{out}$ output resistance		$R_{out}$	$\Omega$		10		
Output voltage range <sup>3)</sup>		$U_{out} - U_{ref}$	V	-2		2	SDx version: $U_{out} - U_{ref} = 0\text{ V} @ I_P = 0$ SDUx version: $U_{out} - U_{ref} = -2\text{ V} @ I_P = 0$
Load capacitance		$C_L$	nF		10		
Electrical offset current referred to primary		$I_{OE}$	A	-45		45	
Nominal sensitivity		$S_N$	mV/A		0.067 0.133		SDx version SDUx version
Magnetic offset current (@ $I_{PN}$ ) referred to primary		$I_{OM}$	A		none		No magnetic core inside, OLCI technology
Sensitivity error @ $I_{PN}$		$\epsilon_S$	%	-0.15		0.15	Factory adjustment
Linearity error 0 ... $I_{PM}$		$\epsilon_L$	% of $I_{PM}$	-0.35		0.35	
Temperature coefficient of $U_{ref}$		$T_{CU_{ref}}$	ppm/K	-80		80	-40 °C ... +85 °C
Temperature coefficient of $I_{OE}$		$T_{CI_{OE}}$	A/K	-2.4		2.4	-40 °C ... +85 °C
Temperature coefficient of $S$		$T_{CS}$	ppm/K	-120		120	-40 °C ... +85 °C
Sum of sensitivity & Linearity error 0 ... $I_{PM}$		$\epsilon_{SL}$	% of $I_{PM}$	-0.5		0.5	Primary busbar centered No return busbar considered <sup>4)</sup>
Total error @ 25 °C @ $I_P = 0$ @ $I_P = \pm I_{PM}$		$\epsilon_{tot}$	% of $I_{PM}$	-0.15 -0.65		0.15 0.65	Primary busbar centered No return busbar considered <sup>4)</sup>
Total error @ -40 °C @ $I_P = 0$ @ $I_P = \pm I_{PM}$		$\epsilon_{tot}$	% of $I_{PM}$	-0.54 -1.25		0.54 1.25	Primary busbar centered No return busbar considered <sup>4)</sup>
Total error @ 85 °C @ $I_P = 0$ @ $I_P = \pm I_{PM}$		$\epsilon_{tot}$	% of $I_{PM}$	-0.50 -1.19		0.50 1.19	Primary busbar centered No return busbar considered <sup>4)</sup>
Delay time @ 10 % of the final output value $I_{PN}$ step		$t_{D10}$	$\mu\text{s}$			2.5	@ 100 A/ $\mu\text{s}$
Delay time @ 90 % of the final output value $I_{PN}$ step		$t_{D90}$	$\mu\text{s}$			2.5	@ 100 A/ $\mu\text{s}$
Frequency bandwidth (-3 dB)		$BW$	kHz		100		
RMS noise current spectral density referred to primary 100 Hz ... 100 kHz 100 kHz ... 1 MHz		$i_{no}$	$\text{mA}/\sqrt{\text{Hz}}$		TBD		
Peak to peak noise current referred to primary: up to 10 kHz up to 100 kHz up to 1 MHz		$I_{no\text{pp}}$	mA		TBD		

- Notes:**
- <sup>1)</sup> This low power coreless transducer may accept up to  $I_{P\text{max}}$  permanent current; at the only condition of respecting the maximum primary conductor temperature (105 °C)
  - <sup>2)</sup> Above 28 V, accuracy performance may change irretrievably
  - <sup>3)</sup> Rounded, actual value is obtained by the following formula:  $\pm I_{PM} \times S_N$
  - <sup>4)</sup> See [page 10](#) typical influence of the return busbar regarding its position.

**Electrical data FL 24000-SDxx200**

 At  $T_A = 25\text{ °C}$ ,  $U_C = +24\text{ V}$ ,  $R_L = 10\text{ k}\Omega$ , unless otherwise noted (see Min, Max, typ, definition paragraph in [page 9](#)).

Parameter		Symbol	Unit	Min	Typ	Max	Comment
Primary nominal current		$I_{PN}$	A		24000		See <sup>1)</sup>
Primary current, measuring range		$I_{PM}$	A	-36000 0		36000 36000	SDx version SDUx version
Supply voltage		$U_C$	V	10		28	See <sup>2)</sup>
Current consumption	SDxx200	$I_C$	mA		200 100	240 120	@ $U_C = 12\text{ V DC}$ @ $U_C = 24\text{ V DC}$
	SDxx300				240 120	280 140	@ $U_C = 12\text{ V DC}$ @ $U_C = 24\text{ V DC}$
Output reference voltage		$U_{ref} - 0\text{ V}$	V	2.48 2.48	2.5 2.5	2.55 2.53	@ $U_C = 12\text{ V DC}$ @ $U_C = 24\text{ V DC}$
$U_{ref}$ output resistance		$R_{ref}$	$\Omega$	16	25	38	
$U_{out}$ output resistance		$R_{out}$	$\Omega$		10		
Output voltage range <sup>3)</sup>		$U_{out} - U_{ref}$	V	-2		2	SDx version: $U_{out} - U_{ref} = 0\text{ V} @ I_P = 0$ SDUx version: $U_{out} - U_{ref} = -2\text{ V} @ I_P = 0$
Load capacitance		$C_L$	nF		10		
Electrical offset current referred to primary		$I_{OE}$	A	-54		54	
Nominal sensitivity		$S_N$	mV/A		0.056 0.111		SDx version SDUx version
Magnetic offset current (@ $I_{PN}$ ) referred to primary		$I_{OM}$	A		none		No magnetic core inside, OLCI technology
Sensitivity error @ $I_{PN}$		$\epsilon_S$	%	-0.15		0.15	Factory adjustment
Linearity error 0 ... $I_{PM}$		$\epsilon_L$	% of $I_{PM}$	-0.35		0.35	
Temperature coefficient of $U_{ref}$		$TCU_{ref}$	ppm/K	-80		80	-40 °C ... +85 °C
Temperature coefficient of $I_{OE}$		$TCI_{OE}$	A/K	-2.9		2.9	-40 °C ... +85 °C
Temperature coefficient of $S$		$TCS$	ppm/K	-120		120	-40 °C ... +85 °C
Sum of sensitivity & Linearity error 0 ... $I_{PM}$		$\epsilon_{SL}$	% of $I_{PM}$	-0.5		0.5	Primary busbar centered No return busbar considered <sup>4)</sup>
Total error @ 25 °C @ $I_P = 0$ @ $I_P = \pm I_{PM}$		$\epsilon_{tot}$	% of $I_{PM}$	-0.15 -0.65		0.15 0.65	Primary busbar centered No return busbar considered <sup>4)</sup>
Total error @ -40 °C @ $I_P = 0$ @ $I_P = \pm I_{PM}$		$\epsilon_{tot}$	% of $I_{PM}$	-0.54 -1.25		0.54 1.25	Primary busbar centered No return busbar considered <sup>4)</sup>
Total error @ 85 °C @ $I_P = 0$ @ $I_P = \pm I_{PM}$		$\epsilon_{tot}$	% of $I_{PM}$	-0.50 -1.19		0.50 1.19	Primary busbar centered No return busbar considered <sup>4)</sup>
Delay time @ 10 % of the final output value $I_{PN}$ step		$t_{D10}$	$\mu\text{s}$			2.5	@ 100 A/ $\mu\text{s}$
Delay time @ 90 % of the final output value $I_{PN}$ step		$t_{D90}$	$\mu\text{s}$			2.5	@ 100 A/ $\mu\text{s}$
Frequency bandwidth (-3 dB)		$BW$	kHz		100		
RMS noise current spectral density referred to primary 100 Hz ... 100 kHz 100 kHz ... 1 MHz		$i_{no}$	mA/ $\sqrt{\text{Hz}}$		TBD		
Peak to peak noise current referred to primary: up to 10 kHz up to 100 kHz up to 1 MHz		$I_{no pp}$	mA		TBD		

**Notes:** <sup>1)</sup> This low power coreless transducer may accept up to  $I_{Pmax}$  permanent current; at the only condition of respecting the maximum primary conductor temperature (105 °C)

<sup>2)</sup> Above 28 V, accuracy performance may change irremediably

<sup>3)</sup> Rounded, actual value is obtained by the following formula:  $\pm I_{PM} \times S_N$

<sup>4)</sup> See [page 10](#) typical influence of the return busbar regarding its position.



**Electrical data FL 28000-SDxx200**

 At  $T_A = 25\text{ °C}$ ,  $U_C = +24\text{ V}$ ,  $R_L = 10\text{ k}\Omega$ , unless otherwise noted (see Min, Max, typ, definition paragraph in [page 9](#)).

Parameter		Symbol	Unit	Min	Typ	Max	Comment
Primary nominal current		$I_{PN}$	A		28000		See <sup>1)</sup>
Primary current, measuring range		$I_{PM}$	A	-42000 0		42000 42000	SDx version SDUx version
Supply voltage		$U_C$	V	10		28	See <sup>2)</sup>
Current consumption	SDxx200	$I_C$	mA		200 100	240 120	@ $U_C = 12\text{ V DC}$ @ $U_C = 24\text{ V DC}$
	SDxx300				240 120	280 140	@ $U_C = 12\text{ V DC}$ @ $U_C = 24\text{ V DC}$
Output reference voltage		$U_{ref} - 0\text{ V}$	V	2.48 2.48	2.5 2.5	2.55 2.53	@ $U_C = 12\text{ V DC}$ @ $U_C = 24\text{ V DC}$
$U_{ref}$ output resistance		$R_{ref}$	$\Omega$	16	25	38	
$U_{out}$ output resistance		$R_{out}$	$\Omega$		10		
Output voltage range <sup>3)</sup>		$U_{out} - U_{ref}$	V	-2		2	SDx version: $U_{out} - U_{ref} = 0\text{ V @ } I_P = 0$ SDUx version: $U_{out} - U_{ref} = -2\text{ V @ } I_P = 0$
Load capacitance		$C_L$	nF		10		
Electrical offset current referred to primary		$I_{OE}$	A	-63		63	
Nominal sensitivity		$S_N$	mV/A		0.048 0.095		SDx version SDUx version
Magnetic offset current (@ $I_{PN}$ ) referred to primary		$I_{OM}$	A		none		No magnetic core inside, OLCI technology
Sensitivity error @ $I_{PN}$		$\epsilon_S$	%	-0.15		0.15	Factory adjustment
Linearity error 0 ... $I_{PM}$		$\epsilon_L$	% of $I_{PM}$	-0.35		0.35	
Temperature coefficient of $U_{ref}$		$TCU_{ref}$	ppm/K	-80		80	-40 °C ... +85 °C
Temperature coefficient of $I_{OE}$		$TCI_{OE}$	ppm/K	-3.4		3.4	-40 °C ... +85 °C
Temperature coefficient of $S$		$TCS$	ppm/K	-120		120	-40 °C ... +85 °C
Sum of sensitivity & Linearity error 0 ... $I_{PM}$		$\epsilon_{SL}$	% of $I_{PM}$	-0.5		0.5	Primary busbar centered No return busbar considered <sup>4)</sup>
Total error @ 25 °C @ $I_P = 0$ @ $I_P = \pm I_{PM}$		$\epsilon_{tot}$	% of $I_{PM}$	-0.15 -0.65		0.15 0.65	Primary busbar centered No return busbar considered <sup>4)</sup>
Total error @ -40 °C @ $I_P = 0$ @ $I_P = \pm I_{PM}$		$\epsilon_{tot}$	% of $I_{PM}$	-0.54 -1.25		0.54 1.25	Primary busbar centered No return busbar considered <sup>4)</sup>
Total error @ 85 °C @ $I_P = 0$ @ $I_P = \pm I_{PM}$		$\epsilon_{tot}$	% of $I_{PM}$	-0.50 -1.19		0.50 1.19	Primary busbar centered No return busbar considered <sup>4)</sup>
Delay time @ 10 % of the final output value $I_{PN}$ step		$t_{D10}$	$\mu\text{s}$			2.5	@ 100 A/ $\mu\text{s}$
Delay time @ 90 % of the final output value $I_{PN}$ step		$t_{D90}$	$\mu\text{s}$			2.5	@ 100 A/ $\mu\text{s}$
Frequency bandwidth (-3 dB)		$BW$	kHz		100		
RMS noise current spectral density referred to primary 100 Hz ... 100 kHz 100 kHz ... 1 MHz		$i_{no}$	$\text{mA}/\sqrt{\text{Hz}}$		TBD		
Peak to peak noise current referred to primary: up to 10 kHz up to 100 kHz up to 1 MHz		$I_{no\text{pp}}$	mA		TBD		

- Notes:**
- <sup>1)</sup> This low power coreless transducer may accept up to  $I_{P\text{max}}$  permanent current; at the only condition of respecting the maximum primary conductor temperature (105 °C)
  - <sup>2)</sup> Above 28 V, accuracy performance may change irremediably
  - <sup>3)</sup> Rounded, actual value is obtained by the following formula:  $\pm I_{PM} \times S_N$
  - <sup>4)</sup> See [page 10](#) typical influence of the return busbar regarding its position.



### Definition of typical, minimum and maximum values

Minimum and maximum values for specified limiting and safety conditions have to be understood as such as well as values shown in “typical” graphs.

On the other hand, measured values are part of a statistical distribution that can be specified by an interval with upper and lower limits and a probability for measured values to lie within this interval.

Unless otherwise stated (e.g. “100 % tested”), the LEM definition for such intervals designated with “min” and “max” is that the probability for values of samples to lie in this interval is 99.73 %.

For a normal (Gaussian) distribution, this corresponds to an interval between  $-3$  sigma and  $+3$  sigma. If “typical” values are not obviously mean or average values, those values are defined to delimit intervals with a probability of 68.27 %, corresponding to an interval between  $-\sigma$  and  $+\sigma$  for a normal distribution.

Typical, maximal and minimal values are determined during the initial characterization of the product.

### Typical input/output characteristics

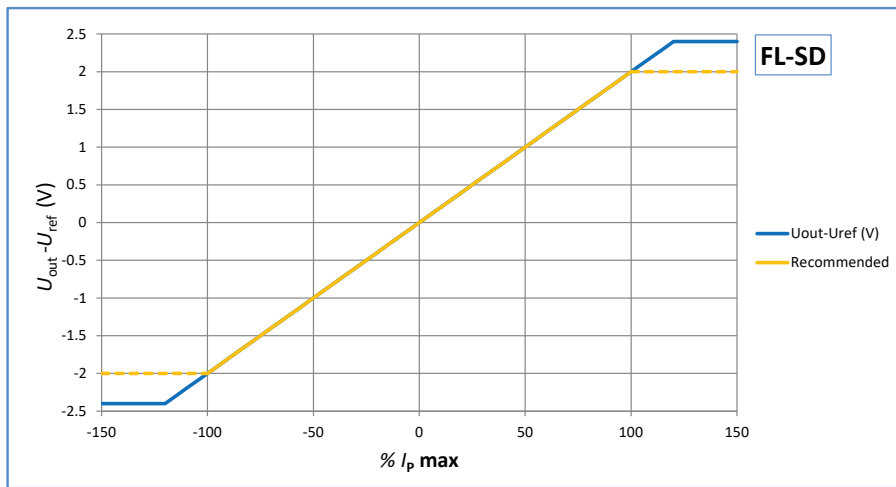

Figure 1: Bi-polar output voltage ( $U_{out} - U_{ref}$ ) VS primary current  $I_p$

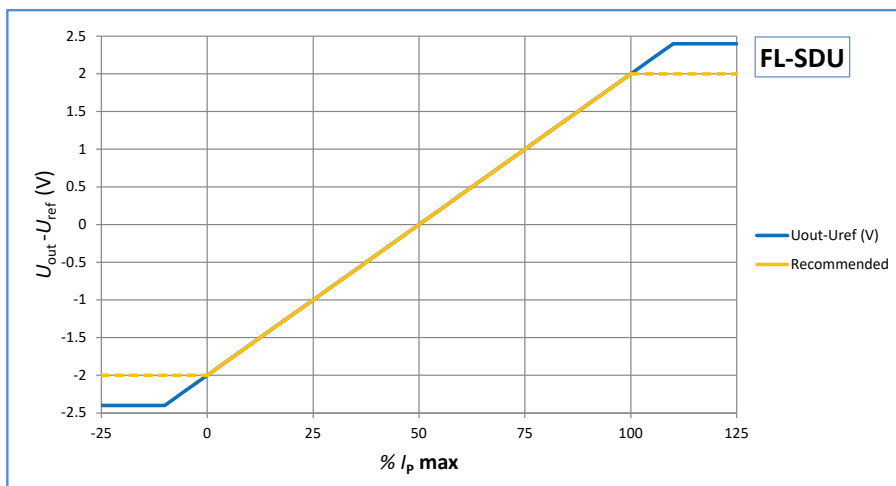
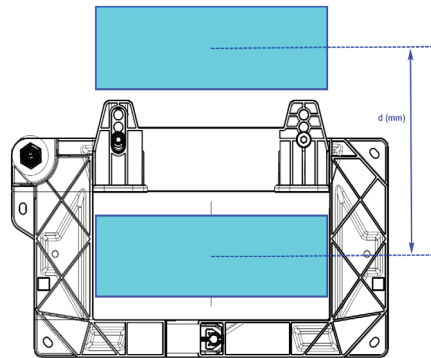
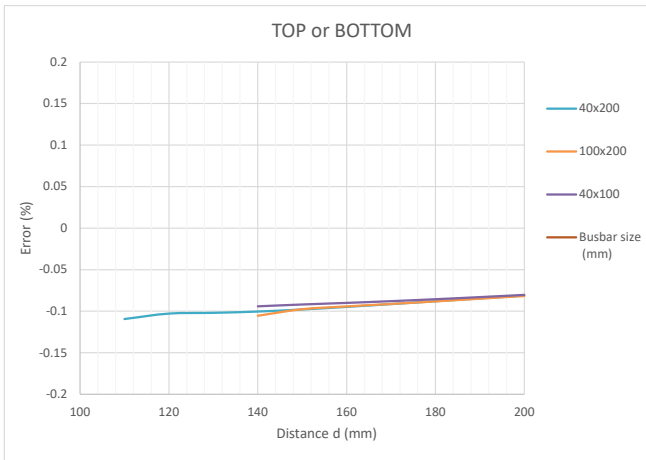
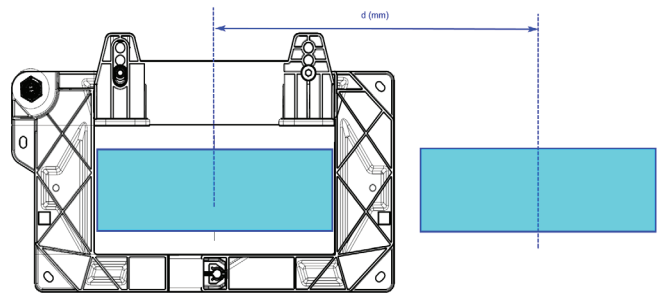
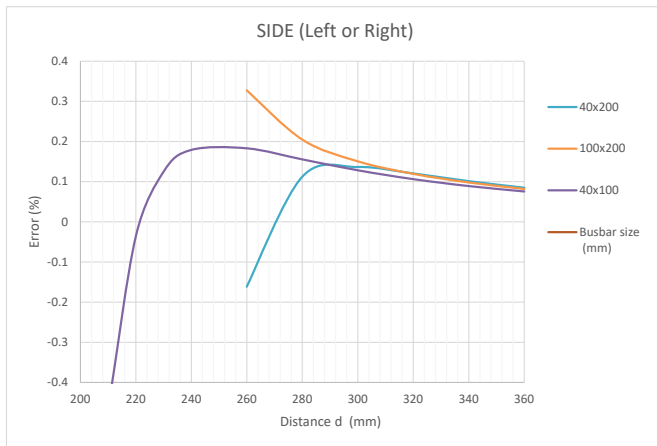

Figure 2: Uni-polar output voltage ( $U_{out} - U_{ref}$ ) VS primary current  $I_p$

Typical additional error due to return busbar layout and distance



Busbar on TOP or BOTTOM



Busbar on the side (LEFT or RIGHT)

FL-SDxxx series: name and codification

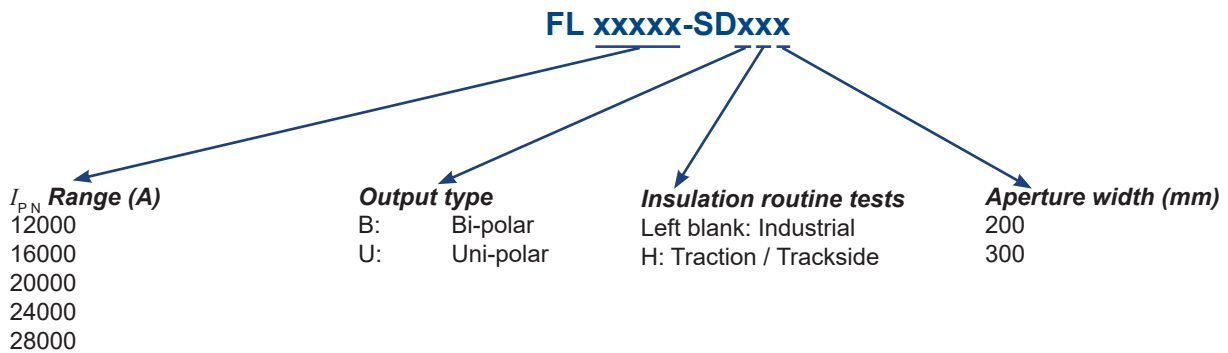

FL-SDxIx series: ordering <sup>1)</sup>

Name	Part numbers	Name	Part numbers
FL 12000-SD200	90.Z2.80.501.0	FL 12000-SDH200	90.Z2.80.531.0
FL 12000-SDU200	90.Z2.80.502.0	FL 12000-SDUH200	90.Z2.80.532.0
FL 16000-SD200	90.Z2.82.503.0	FL 16000-SDH200	90.Z2.82.533.0
FL 16000-SDU200	90.Z2.82.504.0	FL 16000-SDUH200	90.Z2.82.534.0
FL 20000-SD200	90.Z2.84.505.0	FL 20000-SDH200	90.Z2.84.535.0
FL 20000-SDU200	90.Z2.84.506.0	FL 20000-SDUH200	90.Z2.84.536.0
FL 24000-SD200	90.Z2.H7.507.0	FL 24000-SDH200	90.Z2.H7.537.0
FL 24000-SDU200	90.Z2.H7.508.0	FL 24000-SDUH200	90.Z2.H7.538.0
FL 28000-SD200	90.Z2.R9.509.0	FL 28000-SDH200	90.Z2.R9.539.0
FL 28000-SDU200	90.Z2.R9.510.0	FL 28000-SDUH200	90.Z2.R9.540.0
FL 12000-SD300	90.Z2.80.521.0	FL 12000-SDH300	90.Z2.80.551.0
FL 12000-SDU300	90.Z2.80.522.0	FL 12000-SDUH300	90.Z2.80.552.0
FL 16000-SD300	90.Z2.82.523.0	FL 16000-SDH300	90.Z2.82.553.0
FL 16000-SDU300	90.Z2.82.524.0	FL 16000-SDUH300	90.Z2.82.554.0
FL 20000-SD300	90.Z2.84.525.0	FL 20000-SDH300	90.Z2.84.555.0
FL 20000-SDU300	90.Z2.84.526.0	FL 20000-SDUH300	90.Z2.84.556.0
FL 24000-SD300	90.Z2.H7.527.0	FL 24000-SDH300	90.Z2.H7.557.0
FL 24000-SDU300	90.Z2.H7.528.0	FL 24000-SDUH300	90.Z2.H7.558.0
FL 28000-SD300	90.Z2.R9.529.0	FL 28000-SDH300	90.Z2.R9.559.0
FL 28000-SDU300	90.Z2.R9.530.0	FL 28000-SDUH300	90.Z2.R9.560.0

**Note:** <sup>1)</sup> This is an exhaustive list, to date some references may not yet exist, please contact your local LEM's sales support.

Dimensions FL -SDxxx series (in mm)

FL xxxxx-SDxxx-200

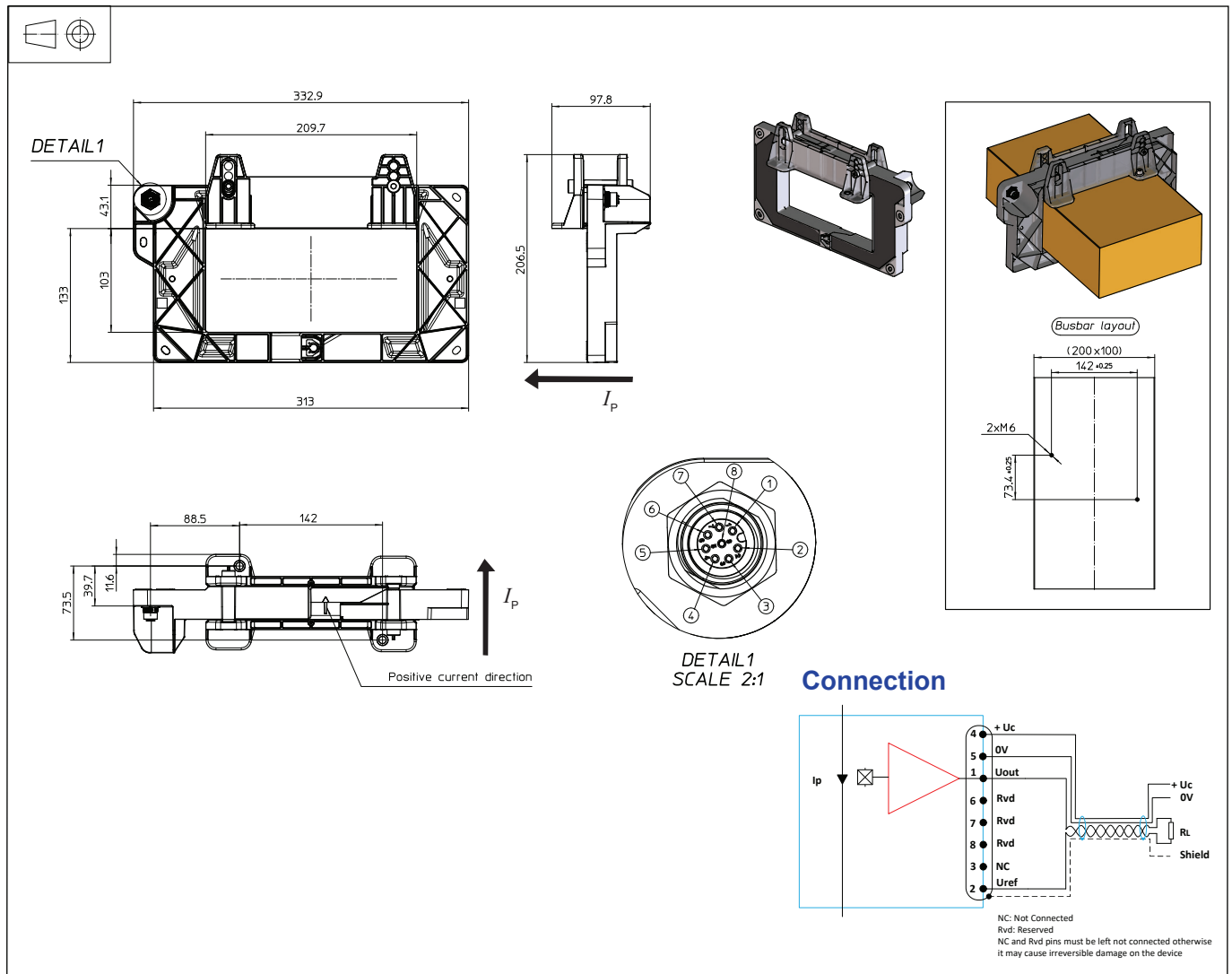

**Mechanical characteristics**

- General tolerance  $\pm 1$  mm
- Maximum primary conductor dimensions:  
200 mm x 100 mm  
300 mm x 100 mm
- Transducer fastening
- Bracket fastening 2 x M6 (supplied)
- Busbar fastening 2 x M6 (not supplied)
- Recommended fastening torque 6 N·m
- Connection to secondary Use M12 Male/Male, coding A, 8 terminals, shielded

**Remarks**

- $I_{out}$  is positive when positive  $I_p$  flows in direction of the arrow shown on the drawing above.
- Temperature of the primary conductor should not exceed 105 °C.
- Installation of the transducer must be done unless otherwise specified on the datasheet, according to LEM Transducer Generic Mounting Rules. Please refer to LEM document N°ANE120504 available on our Web site: <https://www.lem.com/en/file/3137/download>

Dimensions FL-SDxxx series (in mm)

FL xxxxx-SDxxx-300

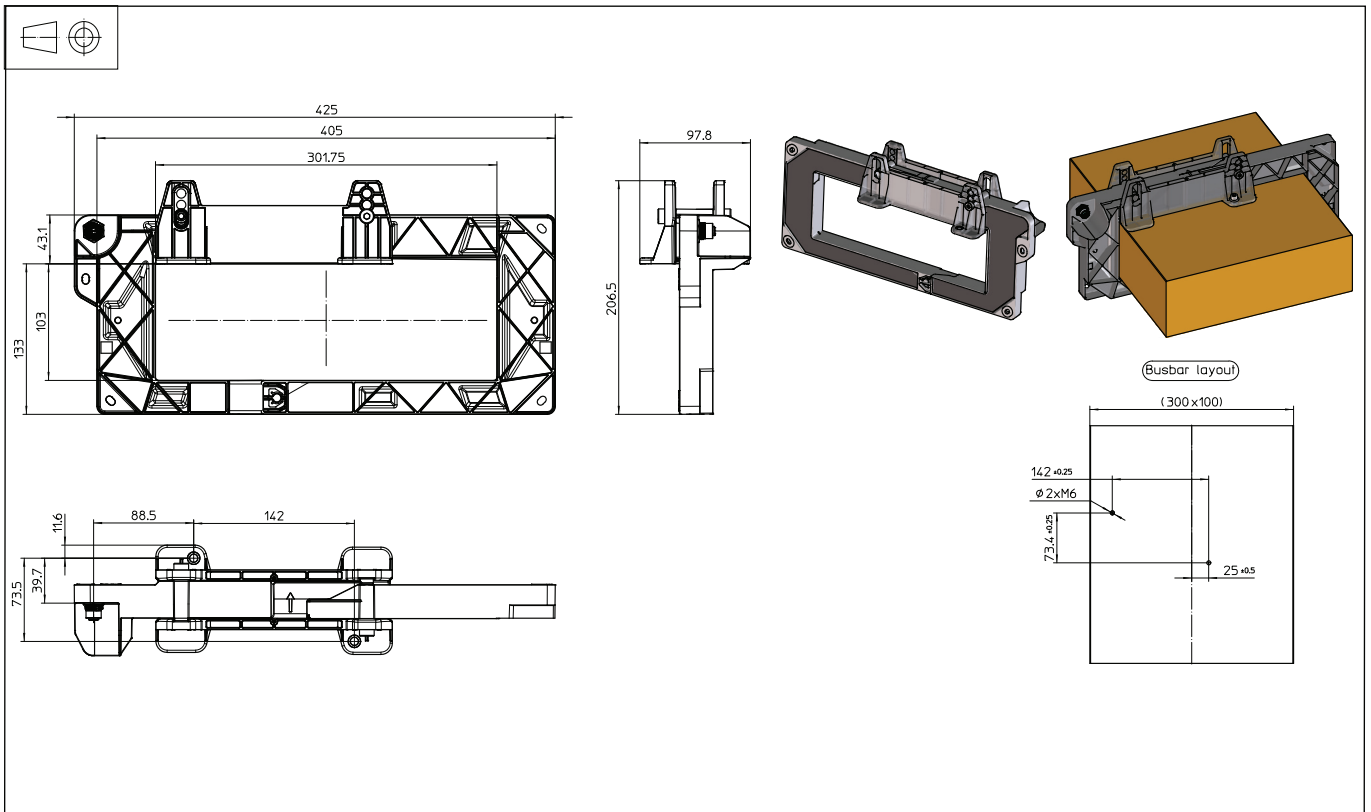

**Mechanical characteristics**

- General tolerance  $\pm 1$  mm
- Maximum primary conductor dimensions:  
 200 mm  $\times$  100 mm  
 300 mm  $\times$  100 mm
- Transducer fastening  
 Bracket fastening 2  $\times$  M6 (supplied)  
 Busbar fastening 2  $\times$  M6 (not supplied)  
 Recommended fastening torque 6 N·m
- Connection to secondary  
 Use M12 Male/Male, coding A, 8 terminals, shielded

**Remarks**

- $I_{out}$  is positive when positive  $I_p$  flows in direction of the arrow shown on the drawing above.
- Temperature of the primary conductor should not exceed 105 °C.
- Installation of the transducer must be done unless otherwise specified on the datasheet, according to LEM Transducer Generic Mounting Rules. Please refer to LEM document N°ANE120504 available on our Web site:  
<https://www.lem.com/en/file/3137/download>