

Sensing & Control

a Honeywell Division

Installation Instructions Explosion Proof Heavy Duty LSX Limit Switches

PK 81181

NON-PLUG-IN
(Single-Pole or Double-Pole)

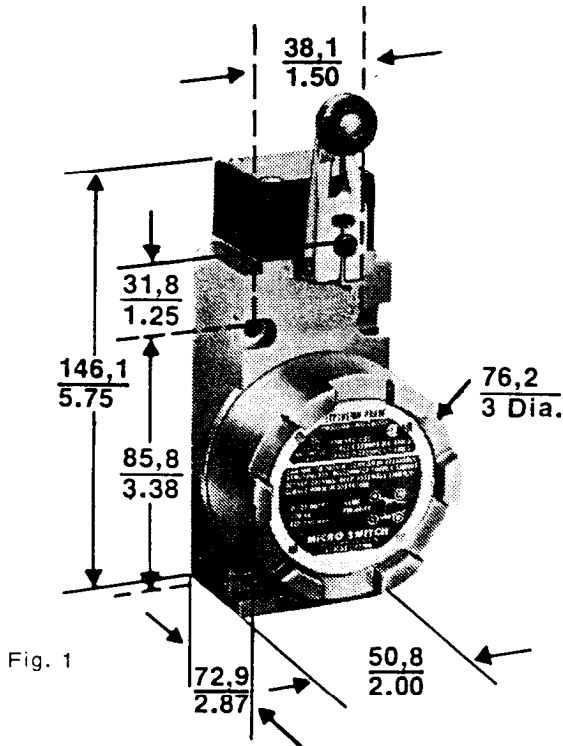
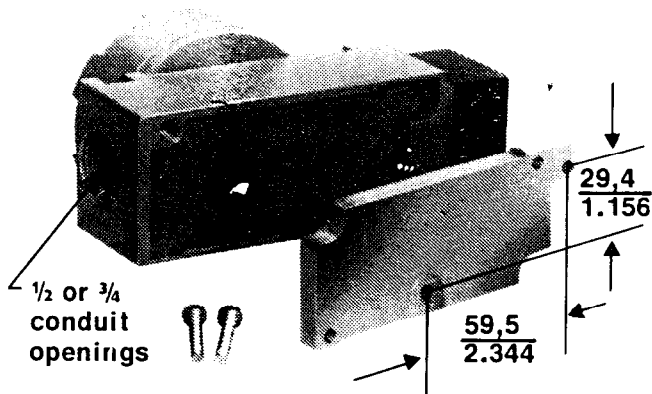

Fig. 1

$\frac{00,0}{0.00} = \frac{\text{mm}}{\text{inches}}$



MICRO SWITCH explosion proof switches are designed specifically for use in hazardous location applications. For a general description and classification of hazardous atmospheres refer to MICRO SWITCH Catalog 40. In addition to meeting explosion proof requirements the LSX meets additional liquid sealing classifications. This makes the LSX ideal for outdoor use or in adverse environments where a combination of explosion proof plus sealing requirements are needed.

To comply with explosion proof requirements the LSX has flame paths within the housing which cool exploding gases below the kindling temperature before they reach explosive gases surrounding the housing. Flame paths on the LSX are (1) an extended plunger between the switch cavity and head and (2) the cover-housing threads on the front of the switch. Liquid sealing is accomplished by an O-ring seal located outside the threads and the same field proven seals of the standard HDLS head.

The LSX enclosure is sealed for protection against corrosion, water, dust and oil as defined in NEMA 1, 3, 3R, 4, 4X, 6, 12 and 13. These enclosures also met NEMA standards for hazardous locations type 7 Class I Groups B, C and D and type 9 Class II Groups E, F and G.

MOUNTING INSTRUCTIONS

ML-E1 MOUNTING

The LSX has the same mounting and tracking as the original MICRO SWITCH explosion proof limit switch (the ML-E1). The ML-E1 has been a standard in the industry for many years and the LSX is interchangeable. The LSX may be mounted with two 1/4 inch screws from the front, or from the back with two 5/16 inch screws. See figure #1.

HDLS MOUNTING

If it is desired to mount on existing HDLS mounting hole locations, the adapter plate (Catalog Listing LSXZ4022) must be used. The adapter plate is attached in the HDLS location. Position the plate so the screw heads fit into the plate recesses provided. Now simply attach the LSX to the adapter plate using the two 3/16 screws and the smaller mounting holes. The mounting plate fits into the recess in the back of the LSX. It is good practice not to mount the switch upside down or at the low point of long conduit runs.

NEW INSTALLATIONS

Note mounting dimension drawing (Figure 1) for hole locations.

PK 81181

WIRING INSTRUCTIONS

The circular cover on the front of the switch is unscrewed to expose the switching element for wiring or replacement. To aid in cover removal, a screwdriver or bar may be used on the wrenching lugs.

Use up to size #12 AWG solid or stranded wire to connect to the pressure type connector terminals. Stripped wire ends or any spade and ring connector that will fit the LS terminals may be used. Spades may be up to .312 inch wide, rings up to .312 inch diameter. With spade or ring type connections, preinsulated connectors or heat-shrinkable tubing should be used to provide insulation

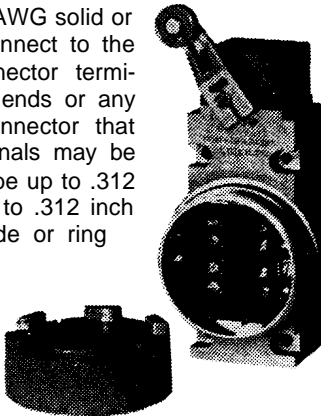

between terminals. Circuit diagram is shown on the name plate.

It will be easier to wire the double pole units by connecting lead wires to the terminals nearest the conduit opening first.

A grounding screw is located on the right side.

ADJUSTING INSTRUCTIONS ACTUATOR HEAD

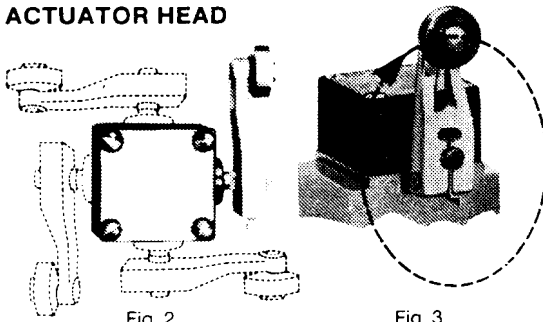

To give flexibility in application, the actuator head may be positioned in any of four directions. Loosen the four captive head screws, place head in the desired position, and then securely tighten the four screws (Fig. 2).

REVERSING THE ROLLER LEVER

Except for the offset roller levers, the roller arm may be reversed to face the roller to the inside or outside of the arm.

POSITIONING LEVER

The lever on rotary actuated units is adjustable to any position through 360° around the shaft. Loosen the cap screw with 9/64-inch hexagon key wrench, move lever to desired position and securely tighten screw (Fig. 3). A 9/64-inch hex key wrench is provided in the adjusting tool set LSZ4005.

ADJUSTABLE LENGTH LEVERS

To adjust the length of the adjustable length levers, a 9/64-inch hexagon key wrench is required. A 9/64-inch key wrench is provided in the adjusting tool set LSZ4005.

TOP ROLLER PLUNGER

Position the top roller plunger in the desired roller plane, by adjusting the head as explained under Actuator Head.

SIDE ROLLER PLUNGE

Grasp the plunger with a pair of pliers and rotate to the desired horizontal or vertical position. (Fig. 4)



Fig. 4

CHANGING DIRECTION OF ACTUATION SIDE ROTARY

Catalog listings with the first four letters LSXA, LSXH, LSXL, LSXP, and LSXR may be adjusted to operate clockwise, counter-clockwise or both. Catalog listings LSXM (center neutral) and LSXN (maintained) operate in both directions and cannot be changed.

To change, follow these steps:

1. Loosen the head screws and remove the head from the switch housing.
2. On the bottom of the head, insert a screwdriver in the slot provided (Fig. 5) and lift open the hinged cover.
3. Referring to Fig. 6, slide the cam all the way back, so cam is free to rotate on the shaft.
4. Using a screwdriver or similar tool, rotate the cam to the desired actuating position. See Figures 7, 8, and 9.
5. Slide the cam all the way forward to its original position, and close the hinged cover.
6. Replace the operating head on the switch housing and securely tighten the head screws.

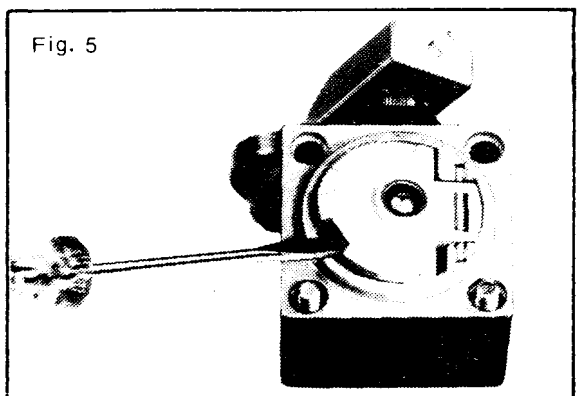

Fig. 5

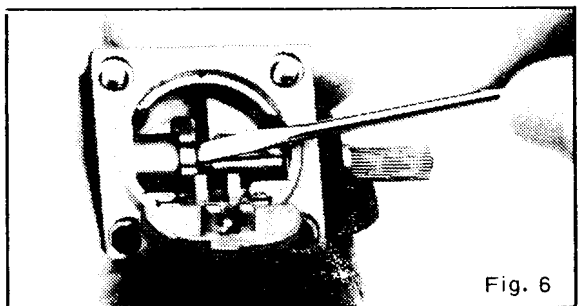
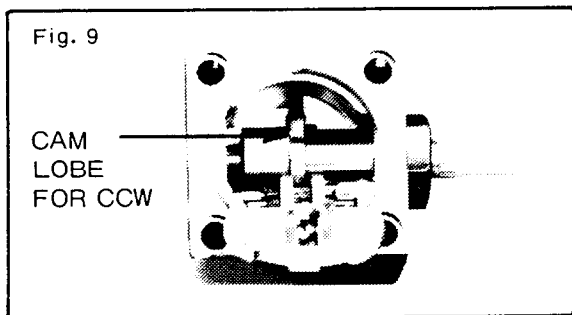
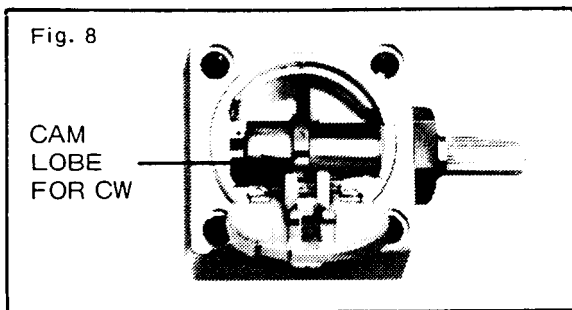
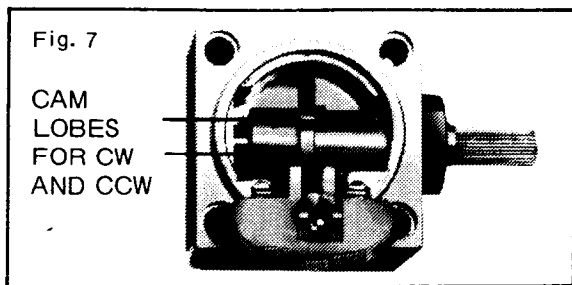

Fig. 6



TOP ROTARY

Follow these steps to change the operating direction of the LSXB type switch:

1. Loosen the head screws and remove head from the switch housing.
2. From the bottom of the head, grasp the end of the pin plunger (Fig. 10) and remove the pin. It may be necessary to rotate the actuating shaft to expose the end of the pin plunger.
3. Referring to Fig. 11, select the correct pin plunger position for the desired direction of actuation.
4. Insert the pin plunger in the position providing the desired direction of actuation.
5. Replace the operating head on the switch housing and securely tighten the head screws.

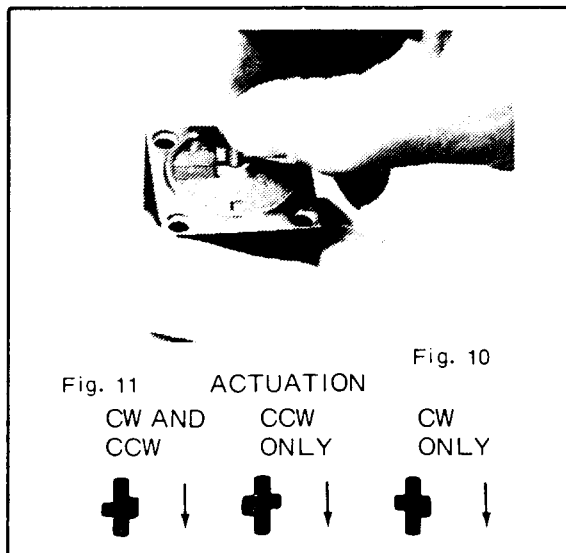

REPLACEMENT PARTS

Following is a list of replacement parts for the heavy duty LS switches. Should your specific switch catalog listing not appear in this list, contact the nearest local MICRO SWITCH Authorized Distributor or a MICRO SWITCH Branch Office.

For ease of making switch adjustments which may be necessary on various switch listings, it is recommended that you order the Lever and Switch Adjusting Tool Set (Catalog Listing - LSZ4005). This set consists of (1) special 3/32-inch open end wrench, and (1) 9/64-inch hexagon key wrench.

REPLACEMENT LEVERS

To order replacement levers, order the same part number as that which is metal stamped on either the lever or lever hub. Use only non-sparking levers to retain the explosion proof qualities.

ADAPTER MOUNTING PLATE

Catalog Listing LSXZ4022

NON-PLUG-IN

Catalog Listing* on Switch Nameplate	Operating Head Only	Contact Block (Basic Switch Only)
LSXA3K	LSZ1A	LSXZ3K
LSXA4L	LSZ1A	LSXZ3L
LSXB3K	LSZ1B	LSXZ3K
LSXB4L	LSZ1B	LSXZ3L
LSXC3K	LSXZ1C	LSXZ3K
LSXC4L	LSXZ1C	LSXZ3L
LSXD3K	LSXZ1D	LSXZ3K
LSXD4L	LSXZ1D	LSXZ3L
LSXE3K	LSXZ1E	LSXZ3K
LSXE4L	LSXZ1E	LSXZ3L
LSXF3K	LSXZ1F	LSXZ3K
LSXF4L	LSXZ1F	LSXZ3L
LSXH3K	LSZ1H	LSXZ3K
LSXH4L	LSZ1H	LSXZ3L
LSXJ3K-7A	LSZ1JGA	LSXZ3K
LSXJ4L-7A	LSZ1JGA	LSXZ3L
LSXK3K-8A	LSXZ1KHA	LSXZ3K
LSXK4L-8A	LSXZ1KHA	LSXZ3L
LSXL4M	LSZ1L	LSXZ3M
LSXM4N	LSZ1M	LSXZ3M
LSXN3K	LSZ1N	LSXZ3K
LSXN4L	LSZ1N	LSXZ3L
LSXP3K	LSZ1P	LSXZ3K
LSXP4L	LSZ1P	LSXZ3L
LSXR3K	LSZ1R	LSXZ3K
LSXR4L	LSZ1R	LSXZ3L

*Only the portion of Catalog listing is shown which determines the replacement part. Listings shown with -7A, or -8A are complete listings.

PK 81181

PROPER APPLICATION OF LIMIT SWITCHES

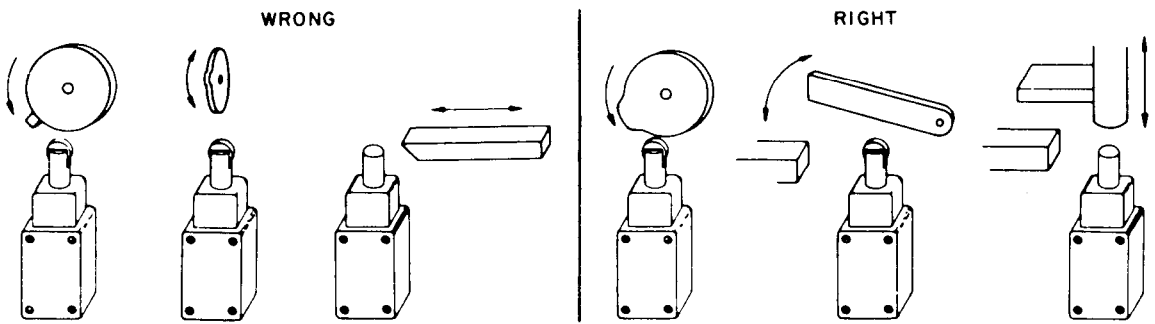

For limit switches with pushrod actuators, the actuating force should be applied as nearly as possible in line with the pushrod axis.

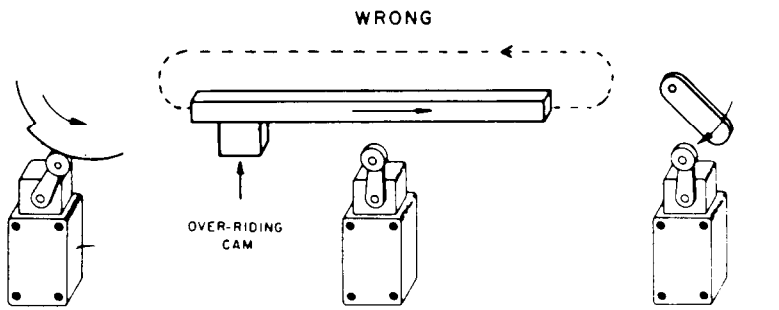

Cam or dog arrangements should be such that the actuator is not suddenly released to snap back freely.

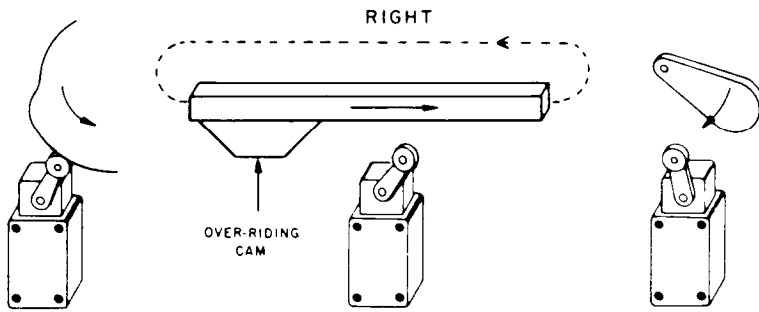

Sensing & Control

a Honeywell Division

IN CANADA: 740 Ellesmere Road, Scarborough, Ontario. INTERNATIONAL: Sales and service offices in all principal cities in the world.