

APML-600JV, APML-600JT

Automotive Photo MOSFET

Description

The Broadcom® APML-600JV/JT is a high-voltage Photo MOSFET that is designed for automotive applications. APML-600JV/JT consists of an AlGaAs infrared light-emitting diode (LED) input stage that is optically coupled to a high-voltage output detector circuit. The detector consists of a high-speed photovoltaic diode array and driver circuitry to switch on/off two discrete high voltage MOSFETs. The Photo MOSFET turns on (contact closes) with a minimum input current of 1.5 mA through the input LED. The Photo MOSFET turns off (contact opens) with an input voltage of 0.4V or less.

The APML-600JV/JT is equivalent to 1 Form A Electromechanical Relays (EMR) and is available in 16-pin SOIC package.

Broadcom R²Coupler™ provides reinforced insulation and reliability that delivers safe signal isolation critical in automotive and high temperature industrial applications.

Functional Diagram

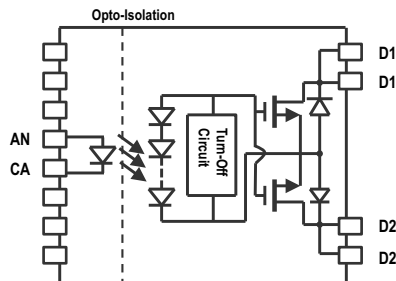

Truth Table

LED	Output
OFF	Open
ON	Close

CAUTION! It is advised that normal static precautions be taken in handling and assembly of this component to prevent damage and/or degradation which may be induced by ESD. The components featured in this data sheet are not to be used in military or aerospace applications or environments.

Features

- Compact solid-state bi-directional signal switch
- Qualified to AEC-Q101 test guidelines
- Automotive temperature range:
 - APML-600JV: $T_A = -40^{\circ}\text{C}$ to $+105^{\circ}\text{C}$
 - APML-600JT: $T_A = -40^{\circ}\text{C}$ to $+125^{\circ}\text{C}$
- Breakdown Voltage, $V_{O(OFF)}$: 1500V at $I_{O(OFF)} = 250 \mu\text{A}$
- Avalanche-rated MOSFETs
- Low off-state leakage:
 - APML-600JV: $I_{O(OFF)} < 500 \text{ nA}$ @ $V_{DS} = 1000\text{V}$
 - APML-600JT: $I_{O(OFF)} < 1000 \text{ nA}$ @ $V_{DS} = 1000\text{V}$
- On-resistance: $R_{ON} < 900\Omega$ at $I_O = 1 \text{ mA}$
- Turn-on time: $T_{ON} < 2.0 \text{ ms}$
- Turn-off time: $T_{OFF} < 0.5 \text{ ms}$
- Package: 300 mil SO-16
- Creepage and Clearance $\geq 8 \text{ mm}$ (input-output)
- Creepage $> 5 \text{ mm}$ (between drain pins of MOSFETs)
- Safety and Regulatory approvals:
 - IEC/EN/DIN EN 60747-5-5
 - Maximum Working Insulation Voltage 1414V_{PEAK}
 - UL/cUL 1577, 5000 V_{RMS} for 1 minute

Applications

- Battery insulation resistance measurement/leakage detection
- Battery Management System (BMS)

Package Pin Out

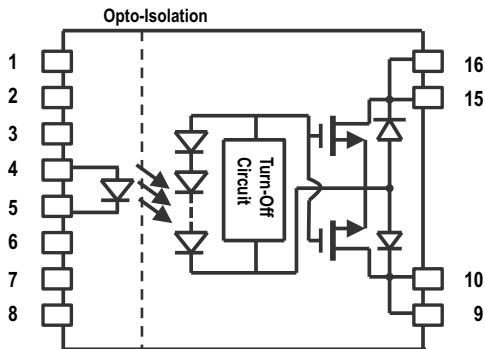

Pin Description

Pin Number	Name	Description
1, 2, 6, 7, 8	NC	No Connection
3	NC	Do not connect (internally connected to Pin 5)
4	AN	Anode
5	CA	Cathode
9, 10	D2	Drain 2 (internally connected)
15, 16	D1	Drain 1 (internally connected)

Ordering Information

Part Number	Option (RoHS Compliant)	Package	Surface Mount	Tape and Reel	UL 5000V _{rms} /1 Minute Rating	IEC 60747-5-5 EN/DIN EN 60747-5-5	Quantity
APML-600JV	-000E	SO-16	X	—	X	X	45 per tube
	-500E		X	X	X	X	850 per reel
APML-600JT	-000E	SO-16	X	—	X	X	45 per tube
	-500E		X	X	X	X	850 per reel

To order, choose a part number from the part number column and combine with the desired option from the option column to form an order entry.

Example 1:

APML-600JT-500E to order product of SO-16 Surface Mount package in Tape and Reel packaging with IEC/EN/DIN EN 60747-5-5 Safety Approval in RoHS compliant.

Option datasheets are available. Contact your Broadcom sales representative or authorized distributor for information.

Package Outline Drawing

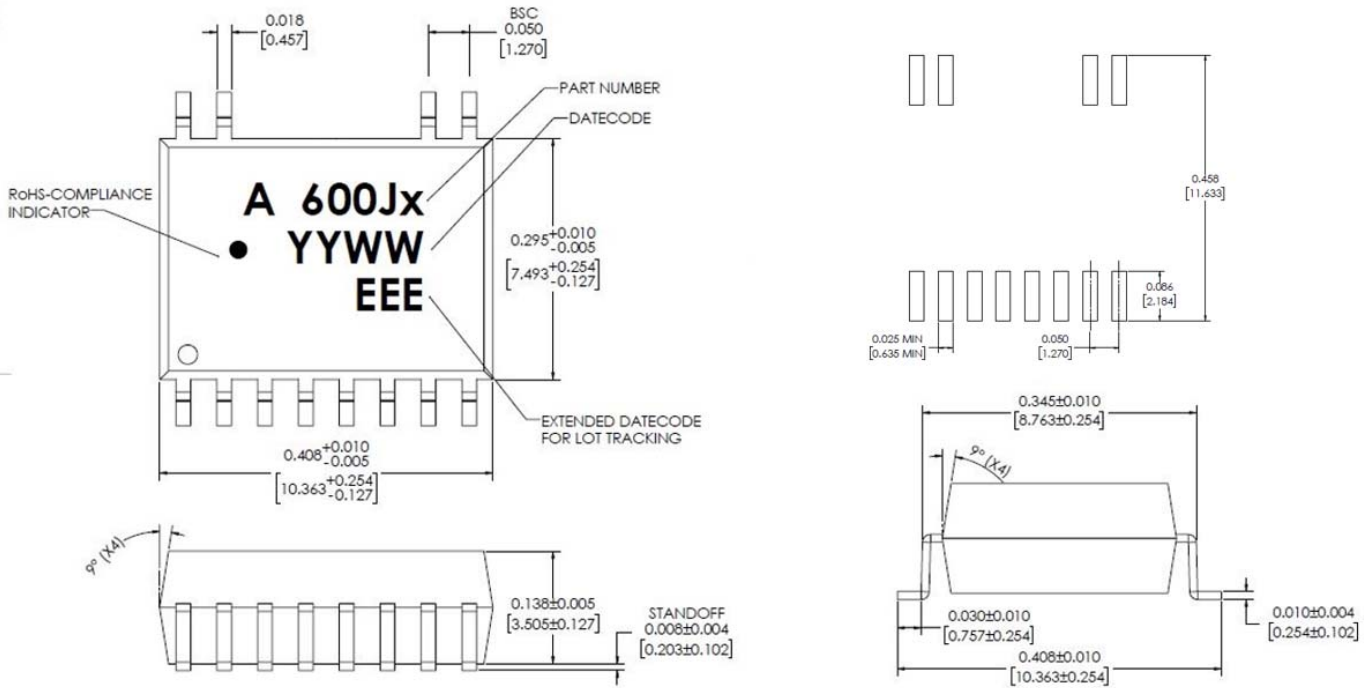

Dimension in inches (millimeters)
 Lead coplanarity = 0.004 inches (0.10mm) Max.
 Floating lead protrusion = 0.010 inches (0.254mm) Max.
 Mold flash on each side = 0.005 inches (0.127mm) Max.

Recommended PB-Free IR Profile

Recommended reflow condition as per JEDEC Standard, J-STD-020 (latest revision).

NOTE: Non-halide flux should be used.

Regulatory Information

The APML-600JV/JT are approved by the following organizations:

UL/cUL	IEC/EN/DIN EN 60747-5-5
UL 1577, component recognition program up to $V_{ISO} = 5 \text{ kV}_{RMS}$ Approved under CAN/CSA-C22.2 No. 62368-1	Maximum Working Insulation Voltage, $V_{IORM} = 1414V_{PEAK}$ Highest Allowable Overvoltage, $V_{IOTM} = 6000V_{PEAK}$

Insulation and Safety-Related Specifications

Parameter	Symbol	Value	Units	Conditions
Minimum External Air Gap (Clearance)	L(101)	8.3	mm	Measured from input terminals to output terminals, shortest distance through air.
Minimum External Tracking (Creepage)	L(102)	8.3	mm	Measured from input terminals to output terminals, shortest distance path along body.
Minimum Internal Plastic Gap (Internal Clearance)		0.05	mm	Through insulation distance conductor to conductor, usually the straight line distance thickness between the emitter and detector.
Tracking Resistance (Comparative Tracking Index)	CTI	> 600	V	IEC 60695

IEC/EN/DIN EN60747-5-5 Insulation Characteristics

Description	Symbol	Characteristic	Units
Installation Classification per DIN VDE 0110/1.89, Table 1 For rated mains voltage < 600 Vrms For rated mains voltage < 1000 Vrms		I-III I-II	
Climatic Classification		40/125/21	
Pollution Degree (DIN VDE 0110/1.89)		2	
Maximum Working Insulation Voltage	V_{IORM}	1414	V_{PEAK}
Input to Output Test Voltage, Method b ^a $V_{IORM} \times 1.875 = V_{PR}$, 100% Production Test with $t_m = 1s$, Partial discharge < 5 pC	V_{PR}	2651	V_{PEAK}
Input to Output Test Voltage, Method a ^a $V_{IORM} \times 1.6 = V_{PR}$, Type and Sample Test, $t_m = 10s$, Partial Discharge < 5 pC	V_{PR}	2262	V_{PEAK}
Highest Allowable Overvoltage ^a (Transient Overvoltage $t_{ini} = 60s$)	V_{IOTM}	6000	V_{PEAK}
Safety-Limiting Values – maximum values allowed in the event of a failure ^b Ambient Safety Temperature Input Current Output Power	T_S $I_{S,INPUT}$ $P_{S,OUTPUT}$	175 400 1200	°C mA mW
Insulation Resistance at T_S , $V_{IO} = 500V$	R_S	> 10^9	Ω

- a. Refer to the optocoupler section of the Isolation and Control Components Designer's Catalog, under Product Safety Regulation section IEC/EN/DIN EN 60747-5-5, for a detailed description of Method a and Method b partial discharge test profiles.
- b. Isolation characteristics are guaranteed only within the safety maximum ratings, which must be ensured by protective circuits in application. Surface mount classification is Class A in accordance with CECC00802.

Absolute Maximum Ratings

All specifications at $T_A = 25^\circ\text{C}$ unless otherwise specified.

Parameter		Symbol	Min.	Max.	Units	Notes
Storage Temperature		T_S	-55	150	$^\circ\text{C}$	
Operating Ambient Temperature		T_A	-40	125	$^\circ\text{C}$	
Junction Temperature		T_J	-40	150	$^\circ\text{C}$	
Input Current	Average	$I_{F(\text{avg})}$	—	10	mA	a
	Surge (50% duty cycle)	$I_{F(\text{surge})}$	—	20	mA	a
Reverse Input Voltage		BV_R	—	6	V	a
Input Power Dissipation		P_{IN}	—	100	mW	
Output Load Current		I_O	—	30	mA	
Output Avalanche Current		I_{AV}	—	0.6	mA	b
Output Power Dissipation		P_O	—	1000	mW	
Lead Soldering Cycle	Temperature		—	260	$^\circ\text{C}$	
	Time		—	10	s	
Solder Reflow Temperature Profile		Recommended reflow condition as per JEDEC Standard J-STD-020 (latest revision)				

a. $T_A = -40^\circ\text{C}$ to 125°C

b. $t_m = 1$ minute, duty cycle = 0.1%, cumulative of 5 minutes over lifetime.

Recommended Operating Conditions

Parameter	Symbol	Device	Min.	Max.	Units	Notes
Input Current (ON)	$I_{F(\text{ON})}$	—	1.5	5	mA	
Input Voltage (OFF)	$V_{F(\text{OFF})}$	—	-5	0.4	V	
Operating Temperature	T_A	APML-600JV	-40	105	$^\circ\text{C}$	
		APML-600JT	-40	125	$^\circ\text{C}$	
Continuous Load Voltage	$ V_O $	—	—	1000	V_{DC}	a
Load Current	$ I_O $	—	—	20	mA	b

a. V_O is the voltage across output terminals, pins 9, 10 and pins 15, 16.

b. I_O is the current across output terminals, pins 9, 10 and pins 15, 16.

Electrical Specifications (DC)

Unless otherwise specified, all minimum/maximum specifications are over recommended operating conditions. All typical values at $T_A = 25^\circ\text{C}$, $I_F = 5\text{ mA}$.

Parameter	Symbol	Device	Min.	Typ.	Max.	Units	Test Conditions	Figure	Notes
Input Reverse Breakdown Voltage	V_R	—	5	—	—	V	$I_R = 10\ \mu\text{A}$		
Input Forward Voltage	V_F	—	1.2	1.41	1.75	V	$I_F = 5\text{ mA}$	1	
Output Withstand Voltage	$ V_{O(OFF)} $	—	1500	1690	—	V	$I_{O(OFF)} = 250\ \mu\text{A}$, $T_A = 25^\circ\text{C}$	3	a, b
Output Leakage Current	$ I_{O(OFF)} $	APML-600JV	—	0.1	500	nA	$V_{O(OFF)} = 1000\text{V}$	4	a
		APML-600JT	—	0.1	1000	nA	$V_{O(OFF)} = 1000\text{V}$	4	a
Output Capacitance	C_{OUT}	—	—	60	—	pF	$V_O = 0\text{V}$, $f = 1\text{ MHz}$	7	a
Output On-Resistance	R_{ON}	—	—	310	900	Ω	$I_O = 1\text{ mA}$	8	
		—	—	200	500	Ω	$I_O = 20\text{ mA}$	8	

a. Device is in OFF state with $V_F < 0.4\text{V}$.

b. Per AEC-Q101, device performance is demonstrated with high temperature reverse bias stress at 1200V (80% of rated voltage).

Switching Specifications (AC)

Unless otherwise specified, all Minimum/Maximum specifications are over recommended operating conditions. All typical values at $T_A = 25^\circ\text{C}$.

Parameter	Symbol	Min.	Typ.	Max.	Units	Test Conditions	Figure	Notes
Turn-On Time	T_{ON}	—	0.3	2.0	ms	$I_F = 1.5\text{ mA}$, $V_{DD} = 40\text{V}$, $R_{LOAD} = 20\text{ k}\Omega$	9, 11	
Turn-Off Time	T_{OFF}	—	0.05	0.5	ms	$I_F = 1.5\text{ mA}$, $V_{DD} = 40\text{V}$, $R_{LOAD} = 20\text{ k}\Omega$	10, 12	

Package Characteristics

Parameter	Symbol	Min.	Typ.	Max.	Units	Test Conditions	Figure	Notes
Input-Output Momentary Withstand Voltage ^a	V_{ISO}	5000	—	—	V_{RMS}	$RH \leq 50\%$, $t = 1\text{ minute}$, $T_A = 25^\circ\text{C}$		b, c
Input-Output Resistance	R_{I-O}	10^9	10^{14}	—	Ω	$V_{I-O} = 1000V_{DC}$		b
Input-Output Capacitance	C_{I-O}	—	0.6	—	pF	$f = 1\text{ MHz}$, $V_{I-O} = 0V_{DC}$		b

a. The Input-Output Momentary Withstand Voltage is a dielectric voltage rating that should not be interpreted as an input-output continuous voltage rating.

b. Device considered a two terminal device: pins 1 to 8 shorted together, and pins 9, 10, 15 and 16 shorted together.

c. In accordance with UL 1577, each optocoupler is proof tested by applying an insulation test voltage $\geq 6000 V_{RMS}$ for 1 second.

Switching Test Circuit and Waveform

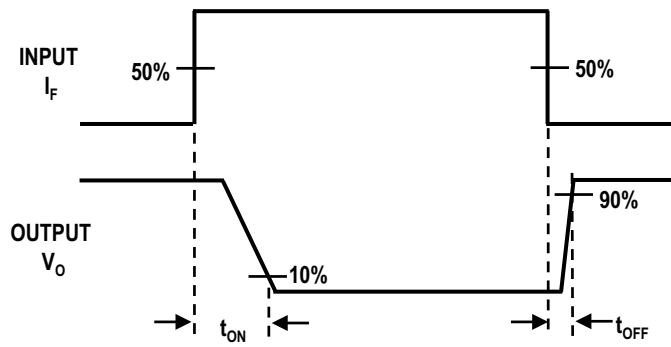
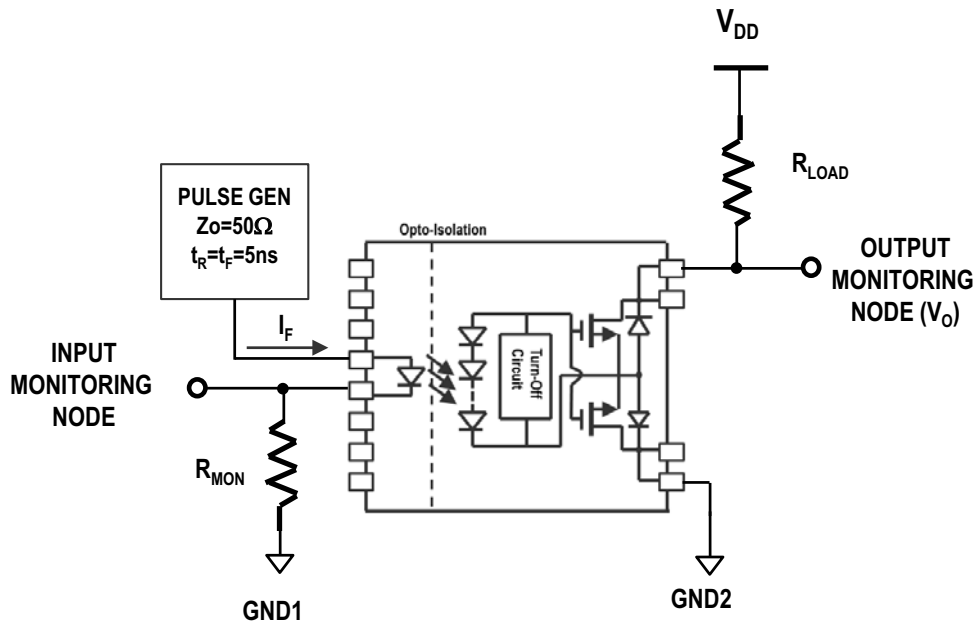

Typical Characteristic Curves

Figure 1: LED Forward Current vs. LED Forward Voltage

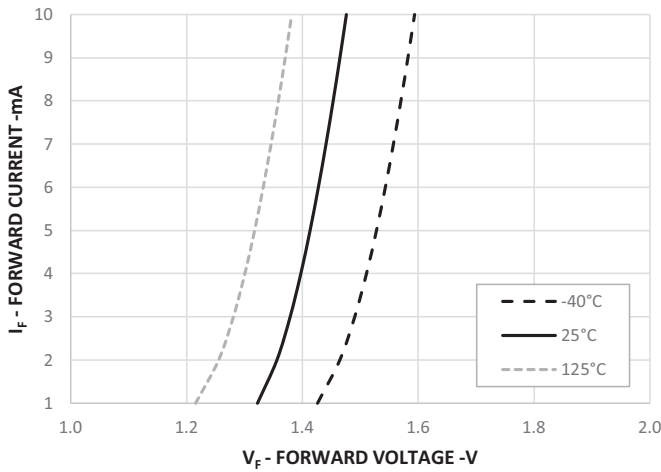

Figure 2: LED Forward Current Threshold vs Temperature

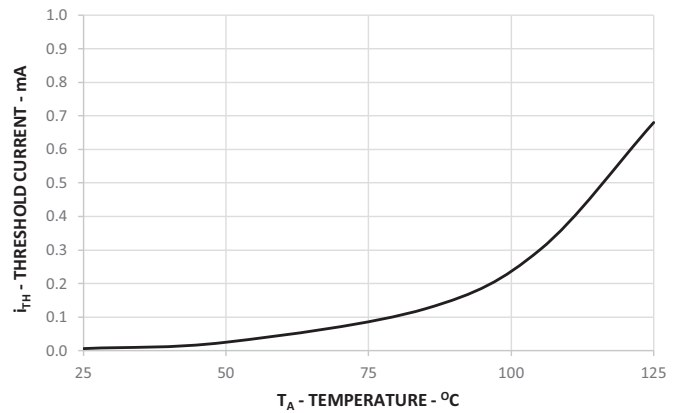

Figure 3: Output Withstand Voltage vs. Temperature (Test Condition: $I_O = 250 \mu A$)

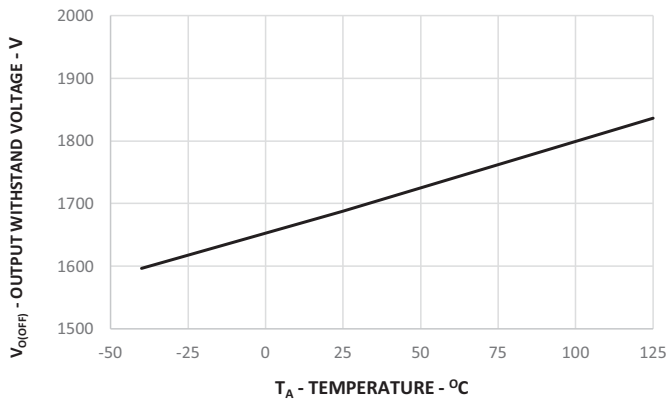

Figure 4: Output Leakage Current vs. Temperature (Test Condition: $V_O = 1000V$)

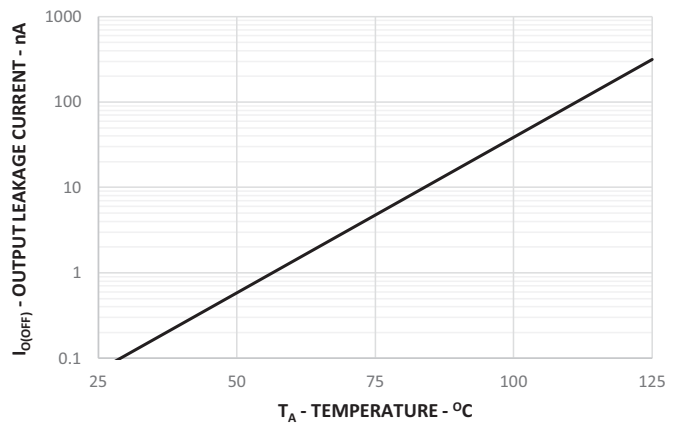

Figure 5: Output Leakage Current vs. Load Voltage (Test Condition: $T_A = 25^\circ C$)

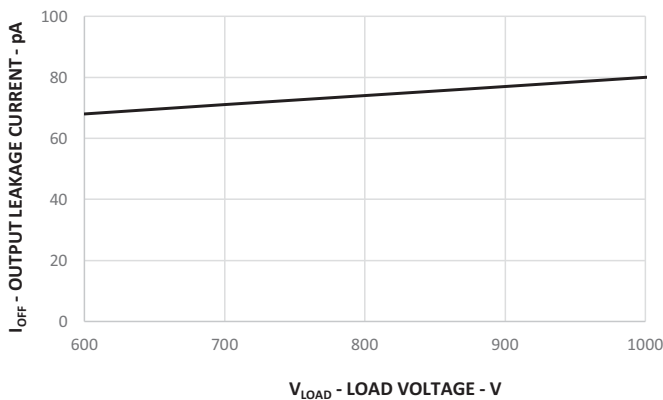

Figure 6: Output Current vs. Output Voltage

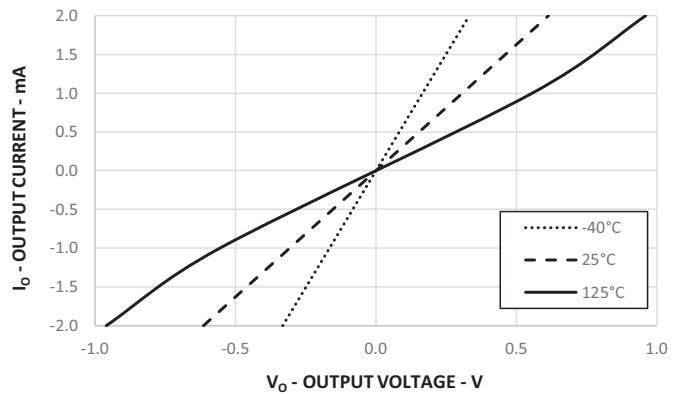

Figure 7: Output Capacitance vs. Load Voltage
(Test Condition: $f = 1 \text{ MHz}$, $T_A = 25^\circ\text{C}$)

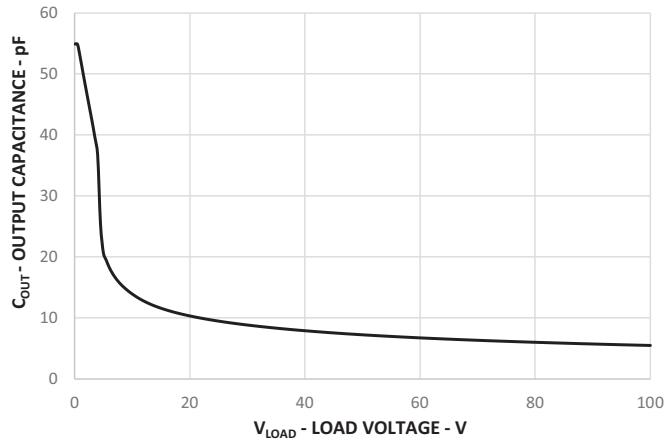

Figure 8: On-Resistance vs. Temperature

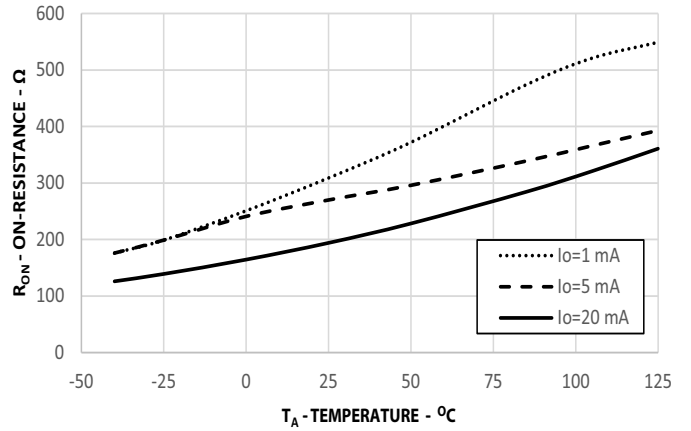

Figure 9: Turn-On Time vs. Temperature
(Test Condition: $V_{DD} = 40\text{V}$, $R_{LOAD} = 20 \text{ k}\Omega$)

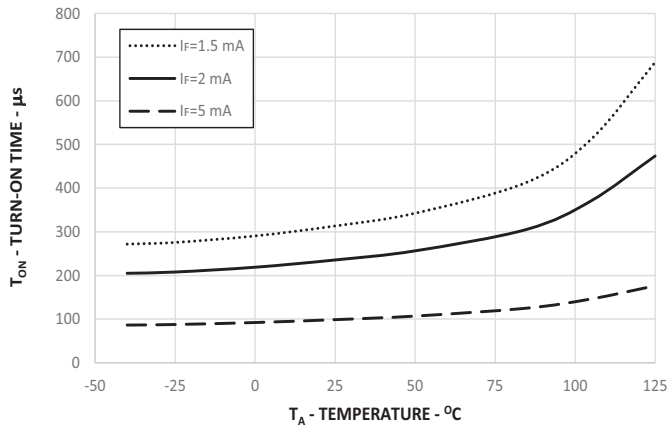

Figure 10: Turn-Off Time vs. Temperature
(Test Condition: $V_{DD} = 40\text{V}$, $R_{LOAD} = 20 \text{ k}\Omega$)

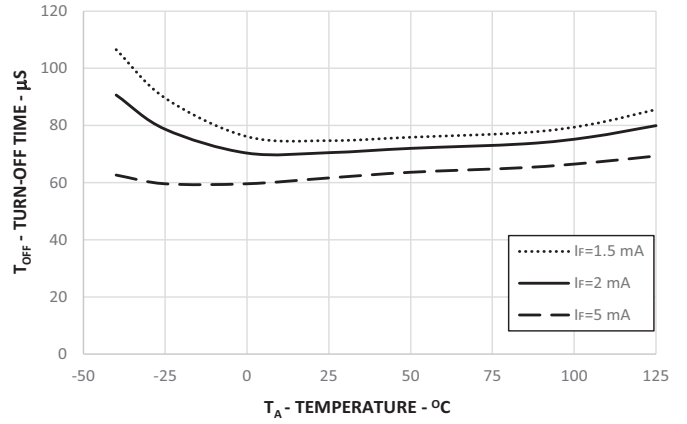

Figure 11: Turn-On Time vs. Input Forward Current
(Test Condition: $V_{DD} = 40\text{V}$, $R_{LOAD} = 20 \text{ k}\Omega$)

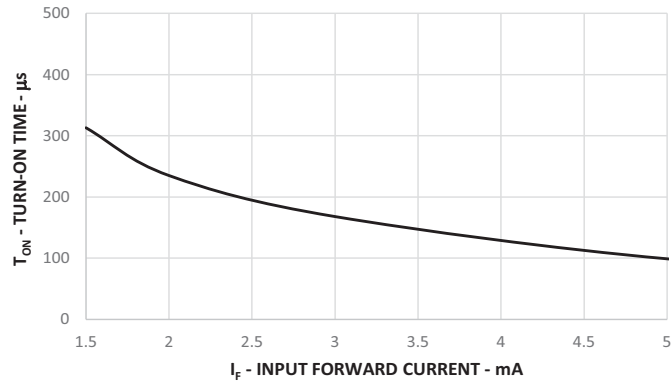
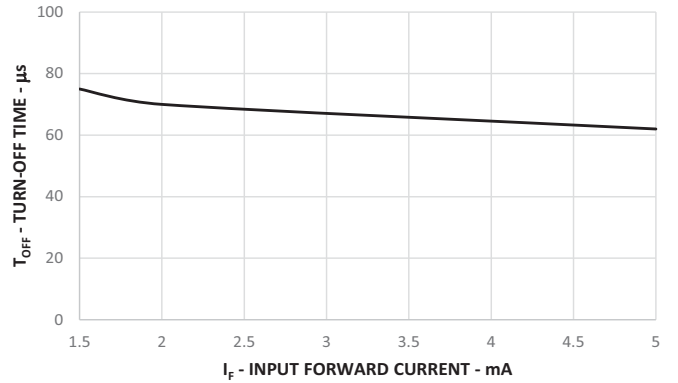

Figure 12: Turn-Off Time vs. Input Forward Current
(Test Condition: $V_{DD} = 40\text{V}$, $R_{LOAD} = 20 \text{ k}\Omega$)



Application Note

APML-600JV/JT is a single-channel PhotoMOSFET that is equivalent to 1 Form A electromechanical relay (EMR) as shown in Figure 13. It functions like a bidirectional switch with no output power requirement. The input side is LED-driven and can be turned on with minimum input current of 1.5 mA.

Figure 13: Equivalent Relay Diagram

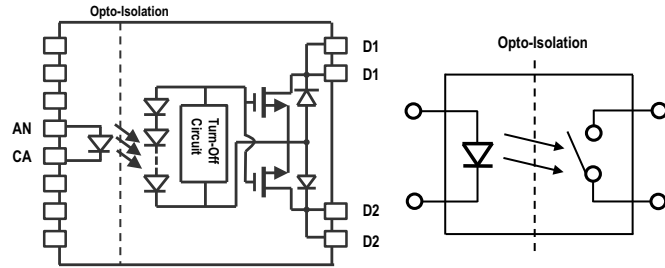

The input LED is optically coupled through a photodiode stack and driver circuit to switch two high voltage MOSFETs. When current is driven into the LED, the light generates photocurrent on the photodiode to charge the gate of the MOSFETs, to switch and keep the power device on.

Preventing Accidental LED Turn-On

In order to prevent the accidental turn-on of the LED due to leakage current in the input, it is recommended to have a definite threshold input current for the LED. This threshold adjustment can be obtained by shunting the LED by a resistor (R_{SHUNT}), the value of which is determined by a ratio between the Input Threshold Current (I_{FT}) and Maximum Input LED Turn-Off Voltage ($V_{F(OFF)MAX}$). The following circuit shows the relationship between these values. The calculations will determine the shunt resistor value required for a given I_{FT} and $V_{F(OFF)MAX}$.

In the following example, the maximum LED Turn-Off voltage is 0.4V (from Absolute Maximum Specification) and the Input Threshold current is set to 100 μ A. The required shunt resistor value is 4 k Ω . In this example, when LED is ON, there will be a typical current value of 350 μ A flowing through the shunt resistor.

Figure 14: Shunt Resistor on the Input

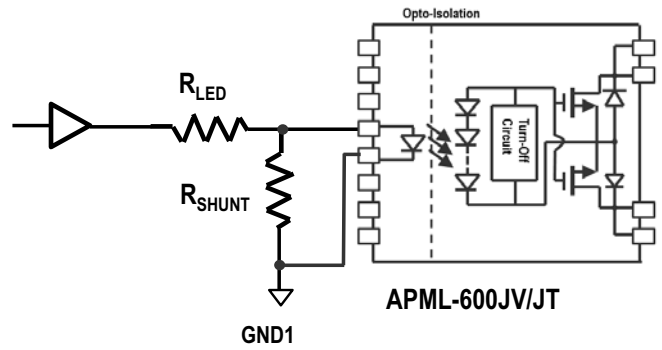

$$R_{SHUNT} = \frac{V_{F(OFF)MAX}}{I_{F(THRESHOLD)}}$$

$$= \frac{0.4V}{100\mu A}$$

$$R_{SHUNT} = 4k\Omega$$

The following typical application circuit shows the APML-600JV/JT input being controlled by the microprocessor to switch the output (high voltage side). The APML-600JV/JT galvanic isolation protects the low voltage side of the circuit (input) from the high voltage side (output).

Pins 8 to 9 and 15 to 16 are internally connected. In routing the PCB layout, either of the pins can be used. Shorting the pins (8 to 9) and (15 to 16) is also acceptable.

Figure 15: Typical Application Circuit

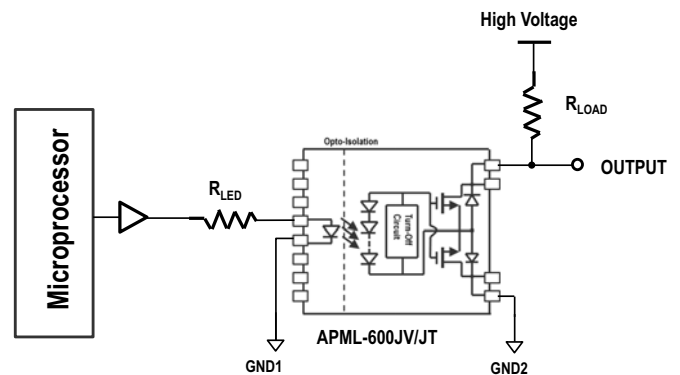

Turn-On Time

T_{ON} is influenced by the level of input current. As input current is increased, the T_{ON} becomes shorter. In a situation where T_{ON} needs to be shorter than what the maximum level of input current can achieve, peaking can be implemented as shown in the following figure.

In this peaking circuit, the LED can be driven by the two inputs to achieve shorter T_{ON} . The duty cycle of the second input V_{IN2} must be set lower in order to achieve the peaking effect.

Figure 16: Peaking Circuit

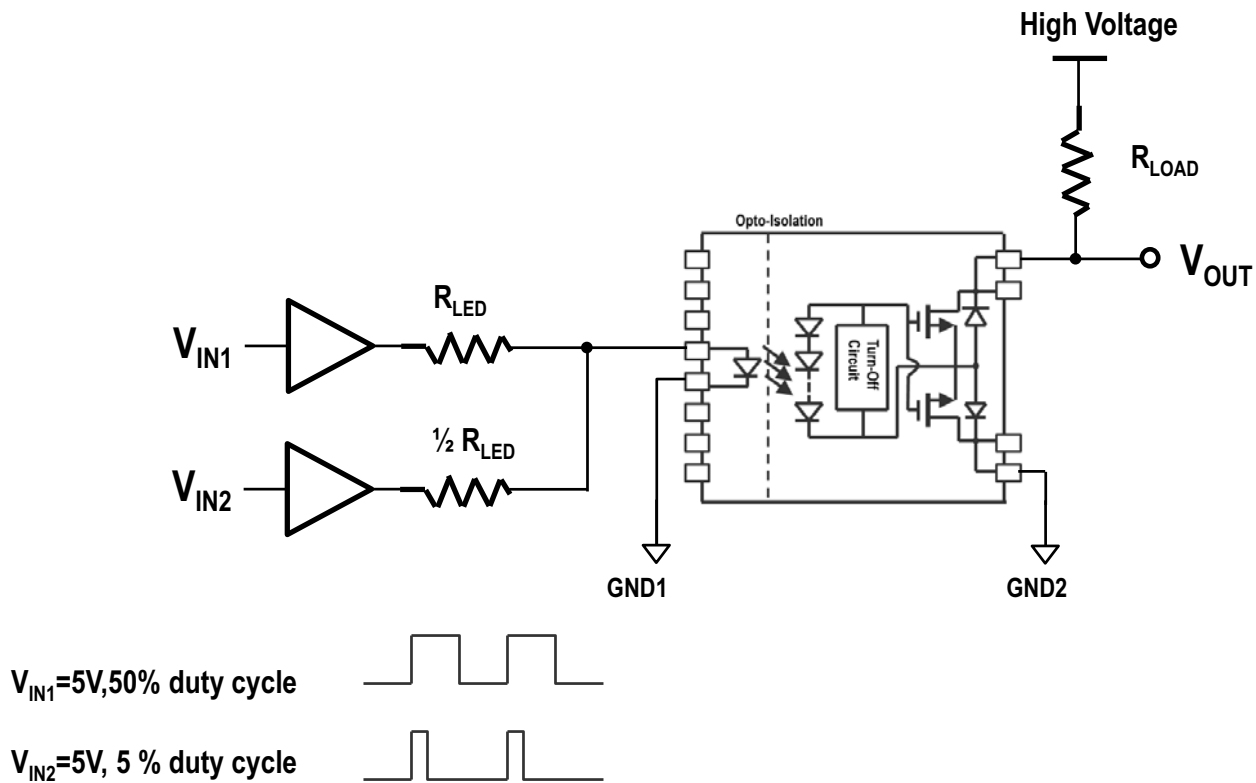

Copyright © 2023 Broadcom. All Rights Reserved. The term “Broadcom” refers to Broadcom Inc. and/or its subsidiaries. For more information, go to www.broadcom.com. All trademarks, trade names, service marks, and logos referenced herein belong to their respective companies.

Broadcom reserves the right to make changes without further notice to any products or data herein to improve reliability, function, or design. Information furnished by Broadcom is believed to be accurate and reliable. However, Broadcom does not assume any liability arising out of the application or use of this information, nor the application or use of any product or circuit described herein, neither does it convey any license under its patent rights nor the rights of others.

