

Dual brushed DC motor driver evaluation board based on STSPIN948

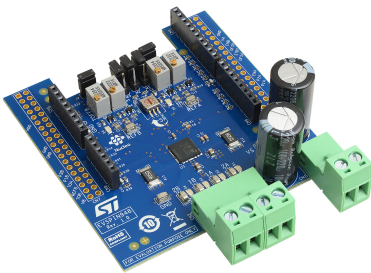

Features

- Voltage range from 5 V to 58 V
- Phase current up to 4.5 A r.m.s
- Adjustable output slew rate
- Five different driving modes
- Current limiter with adjustable off-time
- Two integrated amplifiers with fixed gain
- Full protection set including: overcurrent, undervoltage lockout, and thermal shutdown
- Compatible with Arduino® UNO R3 connector and STM32 Nucleo boards

Description

The **EVSPIN948** dual brushed DC motor driver evaluation board is based on the STSPIN948.

It provides an affordable and easy-to-use solution for the implementation of brushed DC motor driving applications. Thanks to the parallel operation, it can be easily converted to a single brushed DC motor driver with double current capability. In addition to the internal current limiter, the integrated amplifiers allow it to be used in systems with external current control. The EVSPIN948 is compatible with the Arduino® UNO R3 connector and most STM32 Nucleo boards.



Product status link

[EVSPIN948](#)

1 EVSPIN948 schematic diagram

Figure 1. Board schematic

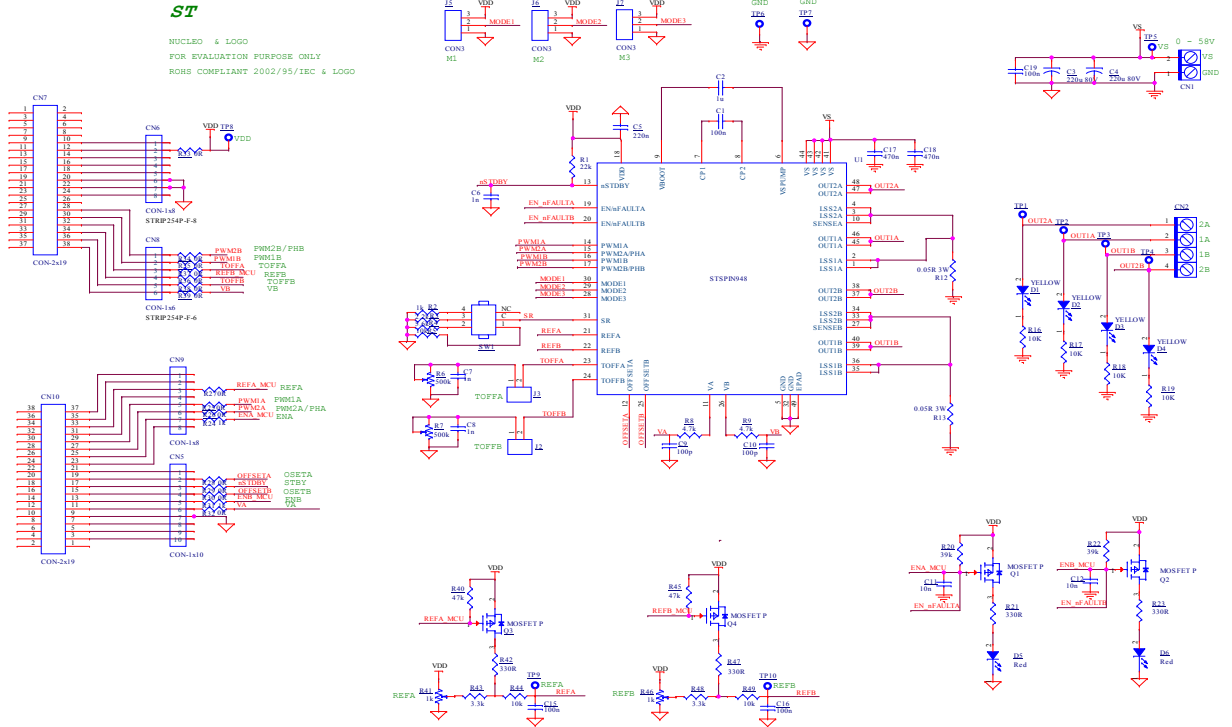

ST
NUCLEO & LOGO
FOR EVALUATION PURPOSE ONLY
ROHS COMPLIANT 2002/95/IEC & LOGO

Revision history

Table 1. Document revision history

Date	Version	Changes
07-Jul-2023	1	Initial release.
19-Oct-2023	2	Updated board current rating



Contents

1	EVSPIN948 schematic diagram	2
	Revision history	3

IMPORTANT NOTICE – READ CAREFULLY

STMicroelectronics NV and its subsidiaries (“ST”) reserve the right to make changes, corrections, enhancements, modifications, and improvements to ST products and/or to this document at any time without notice. Purchasers should obtain the latest relevant information on ST products before placing orders. ST products are sold pursuant to ST’s terms and conditions of sale in place at the time of order acknowledgment.

Purchasers are solely responsible for the choice, selection, and use of ST products and ST assumes no liability for application assistance or the design of purchasers’ products.

No license, express or implied, to any intellectual property right is granted by ST herein.

Resale of ST products with provisions different from the information set forth herein shall void any warranty granted by ST for such product.

ST and the ST logo are trademarks of ST. For additional information about ST trademarks, refer to www.st.com/trademarks. All other product or service names are the property of their respective owners.

Information in this document supersedes and replaces information previously supplied in any prior versions of this document.

© 2023 STMicroelectronics – All rights reserved