

INTRODUCTION

This is an exceptional high-torque, waterproof digital servo with a magnetic encoder, boasting a maximum torque of 25kg. It features a 12-bit high-precision magnetic encoder sensor that allows for precise and absolute control of the servo's position within a 360-degree range, ensuring unparalleled accuracy. With its improved linear motion capability, this servo provides unparalleled performance.

Internally, it utilizes a gear system made of reinforced steel gears with an optimized center distance of 2.0, ensuring durability and enhanced power transmission. The servo incorporates a dual ball bearing design for smoother operation and features an aluminum housing that enhances its heat dissipation capabilities, resulting in a longer lifespan.



Additionally, this servo is equipped with electronic and temperature protections, ensuring a safer user experience. In the event of a servo lock-up, it automatically triggers a protective torque output when the torque exceeds the overload capacity for a continuous period of 4 seconds. Moreover, should the servo's temperature surpass 70 degrees, it ceases torque output, only to resume once the temperature drops below 70 degrees.



To enhance its water resistance, the servo's joints are fortified with waterproof gaskets, and the circuit board is coated with a waterproof varnish. Both the motor and the potentiometer are sealed with a specialized adhesive. These measures contribute to the servo's exceptional waterproof capabilities. Moreover, this servo is accompanied by a selection of different-shaped servo horns, enabling its application in a wider range of environments.

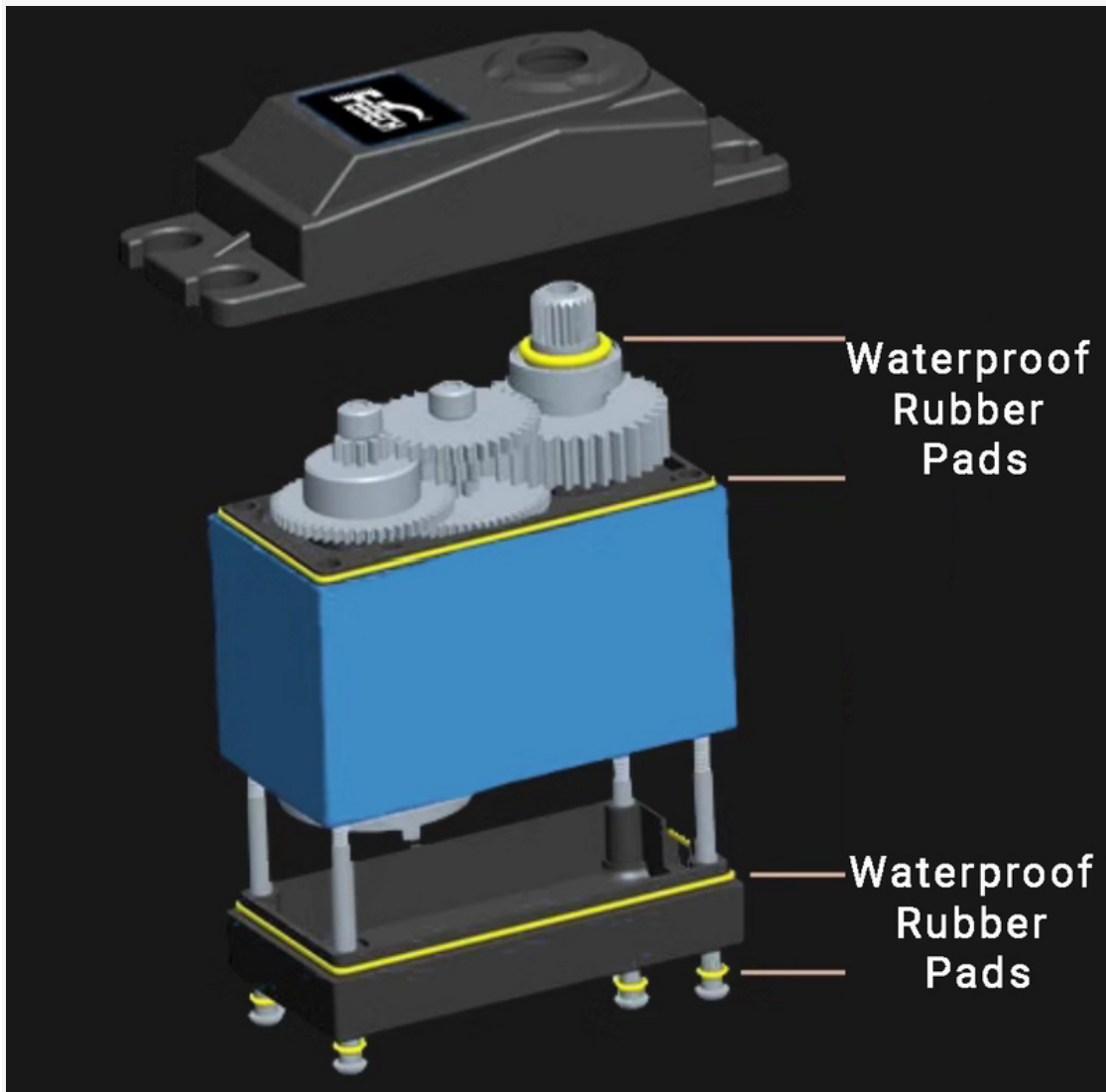

Interface Definition Diagram

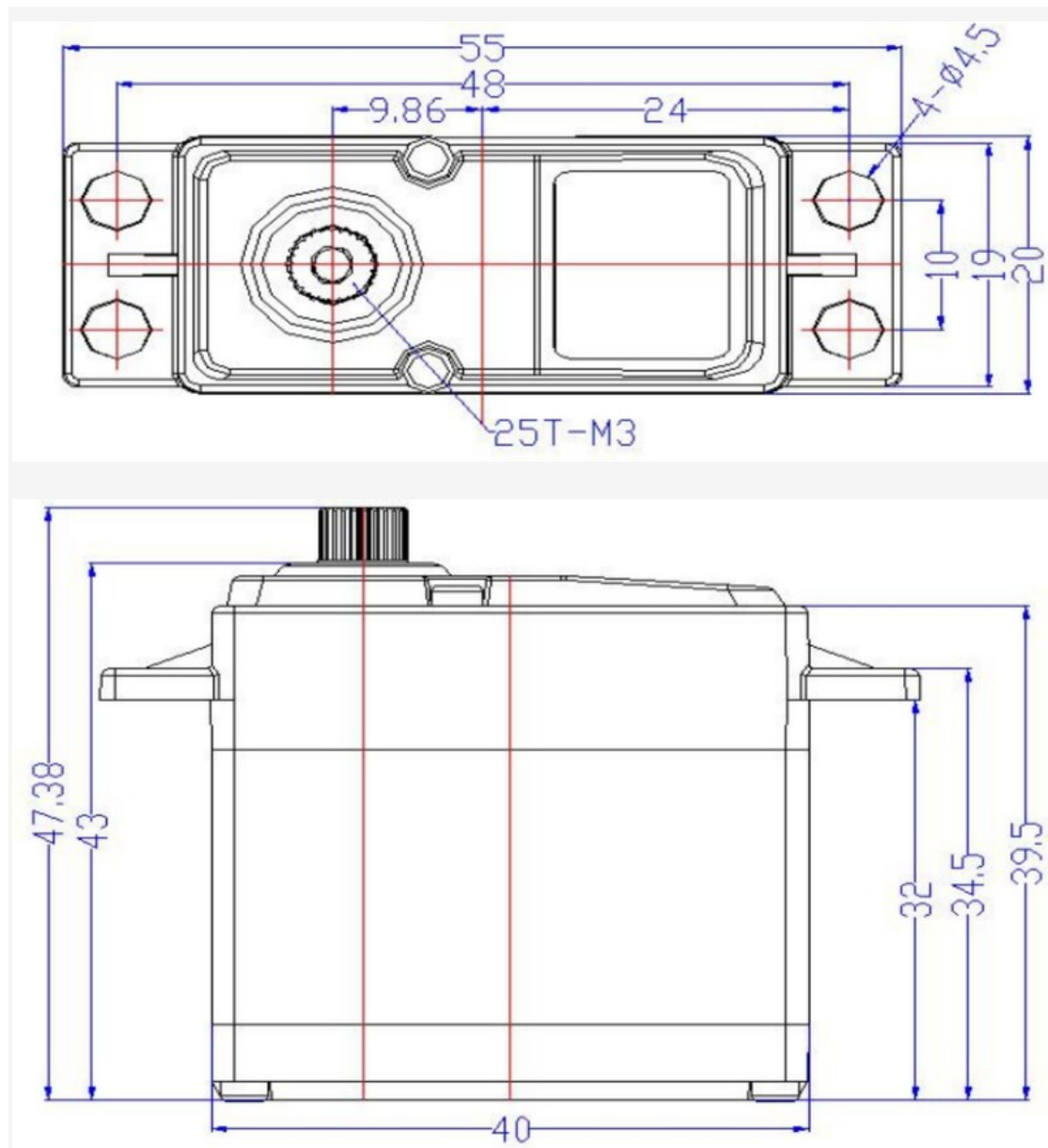

Dimensional Diagram

APPLICATIONS

- Build robots
- Driving part of various automated equipment

SPECIFICATION

Electrical characteristics

- Operating Voltage: 5-8.4V
- No-Load Speed: 0.185sec/60°(54RPM)@6V, 0.151sec/60°(66RPM)@7.4V
- Operating Current: 100mA@6V, 120mA@7.4V
- Stall Torque: 20.5kg.cm/285.19oz.in@6V, 25kg.cm/347.79oz.in@7.4V

- Stall Current: 3A@6V, 3.5A@7.4V
- Static Current: 6mA
- Rated Load: 7kg.cm@6V, 8.5kg.cm@7.4V
- Rated Current: 1000mA@6V, 1200mA@7.4V
- Kt Constant: 7kg.cm/A

Control characteristics

- Control Signal: PWM
- Angle: 360° (at 500→2500μsec)
- Angle Difference: ≤1°
- Return Difference: ≤1°
- Neutral Position: 1500μsec
- Dead Band Width: ≤4μsec
- Rotation Direction: Counterclockwise (from 1500 → 2000μsec)
- Pulse Width Range: 500→2500μsec
- Signal High Voltage: 2-5V
- Signal Low Voltage: 0-0.45V
- Signal Period: 20ms

Mechanical specifications

- Casing Material: PA+Aluminum
- Gear Material: Steel
- Bearing Type: Ball Bearing
- Output Shaft: 25T/5.9mm
- Reduction Ratio: 1/275
- Gear Backlash: ≤0.5°
- Arm Backlash: 0°
- Output Shaft Screw: M3X6

Mechanical specifications

- Motor Noise: 45±5dB
- Servo No-Load Noise: 65±5dB
- Waterproof Rating: IP54 (splash-proof)
- Electronic Protection: 4 seconds lock-up
- Temperature Protection: >70°C
- Storage Temperature: -30°C~80°C
- Operating Temperature: -20°C~60°C

SHIPPING LIST

- Metal Magnetic Encoder Servo-25KG 360° x1
- Metal Servo Arm x1
- Servo Horn Accessories Pack x1

