

INTRODUCTION

This compact STM32F411 development board can be well embedded in your projects. Featuring the STM32F411CEU6, this chip has 512KB of ROM, 128KB of SRAM and runs at 100MHz. There is a spot on the bottom for SOIC flash memory, which allows you to solder SPI flash memory to give yourself more space for data logging or file storage.

The board features a Type-C connector and a 3.3V 100mA LDO regulator. Also, a diode is connected in series to prevent power backflow. There are both 25Mhz 9pF high-speed and 32.768Khz 6pF low-speed crystals on board.

This dev board is suitable for advanced users with STM32 development experience, we do not have a detailed tutorial usage for it.

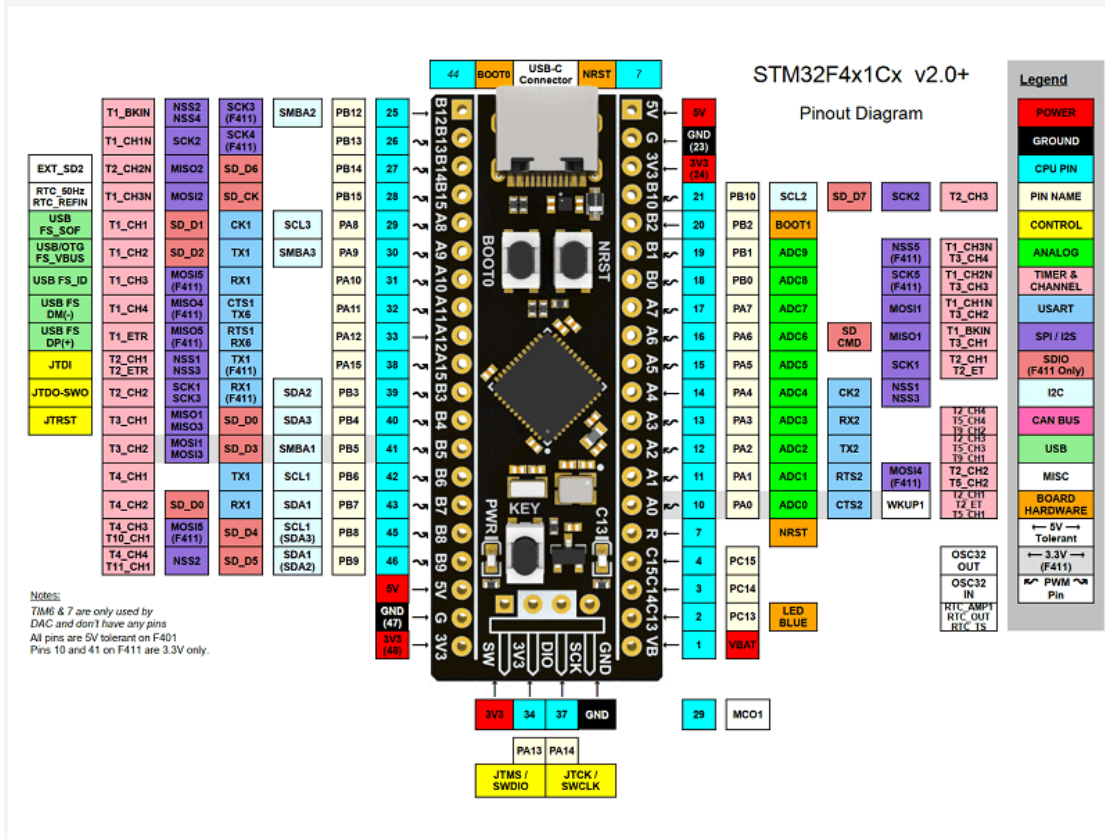

Pinout Diagram

FEATURES

- STM32F411CEU6 100Mhz, 128KB RAM, 512KB ROM
- 25MHZ high-speed crystal & 32.768Khz 6PF low-speed crystal
- Immersion gold technology and lead-free, gold-plated pin headers, more environmentally friendly

- Flash pads have been reserved and USBDisk & FATFFS routines are provided
- Support MicroPython programming, provide usable MicroPython firmware
- Support Arduino programming
- Support C language programming development
- Version V3.0, there are 3 buttons: reset button, BOOT0 button, user button
- Provide CMSIS-DAP firmware, which can be turned into a download burner
- Use the latest original ST chip, high-quality crystal oscillator

DOCUMENTS

- [Example Code & Firmware](#)
- [Arduino IDE Programming](#)
- [MicroPython Tutorial](#)
- [STM32F411CE](#)

SHIPPING LIST

- STM32F411 Development Board x1
- 20Pin Straight Pin x2
- 4Pin Curved Pin x1