

MC20805A12W-VNMLR	2 x 8	5mm Character Height	VA Module
Specification			
Version: 1		Date: 29/09/2016	
Revision			

Display Features				
Character Count	2 x 8			
Appearance	Red on Black			
Logic Voltage	5V			
Interface	Parallel			
Font Set	English / Japanese			
Display Mode	Transmissive			
Character Height	5.56mm			
LC Type	VATN			
Module Size	58.00 x 32.00 x 13.20 mm			
Operating Temperature	-20°C ~ +70°C			
Construction	COB		Box Quantity	Weight / Display
LED Backlight	Red		---	---

* - For full design functionality, please use this specification in conjunction with the RW1063 specification. (Provided Separately)

Display Accessories	
Part Number	Description
MCCMDB-16DIL	LCD Interconnect board, can be driven from either a PC or a single Board computer with a USB output.
MCCBL1A16DLIP-16DILS-150	16 Way, Dual in-line to Dual In-line connector Cable.

Optional Variants		
Fonts	Appearances	Voltage
	Blue on Black White on Black Yellow on Black Green on Black	



Mechanical Specifications

Module Size	58.00 x 32.00 x 13.20 (With Backlight)				W x H x D mm
Viewing Area	38.00 x 16.00	W x H mm	Hole-to-Hole	53.00 x 26.20	W x H mm
Character Size	2.96 x 5.56	W x H mm	Character Pitch	3.55 x 5.94	W x H mm
Dot Size	0.56 x 0.66	W x H mm	Dot Pitch	0.60 x 0.70	W x H mm

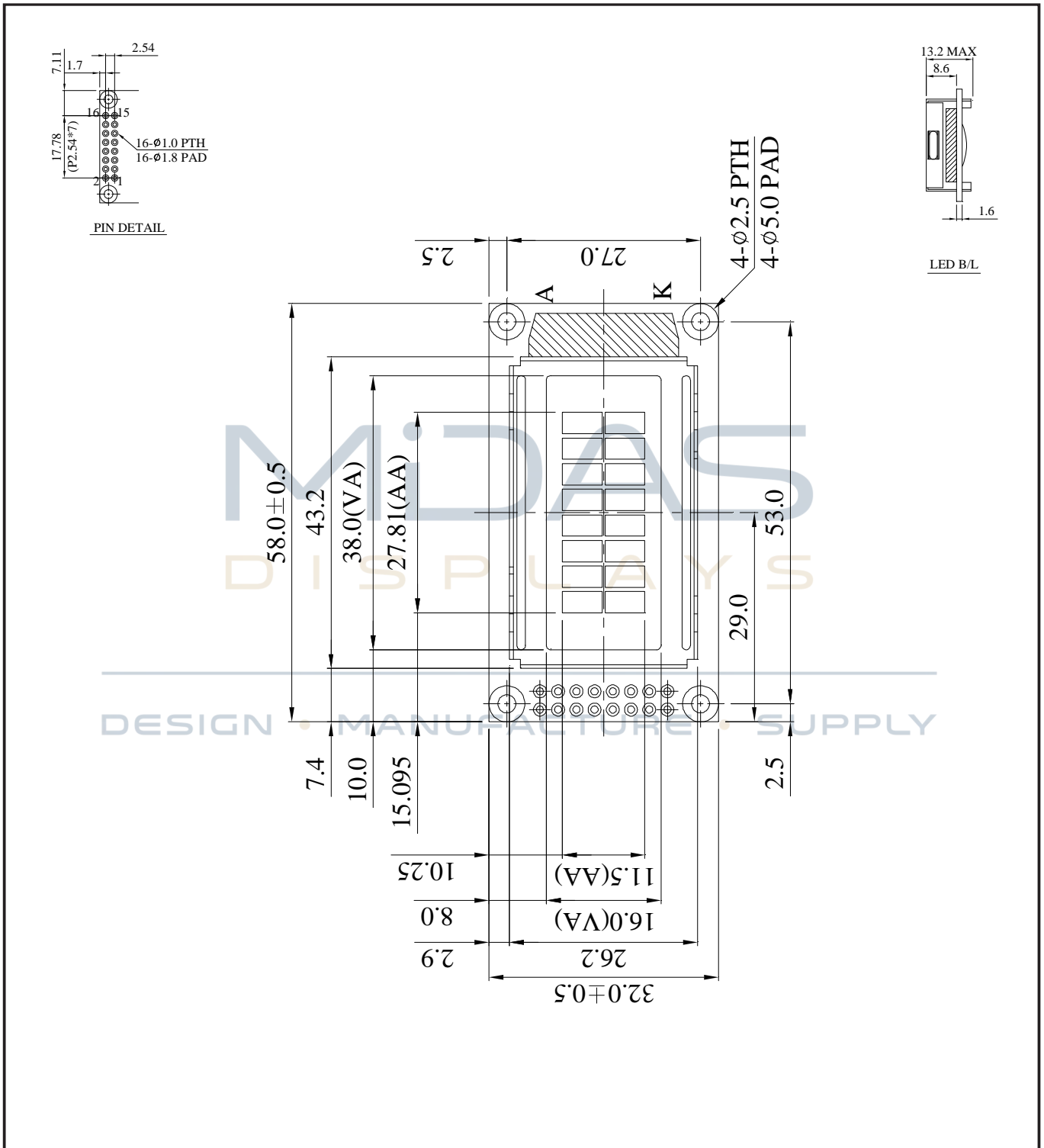

MC20805A12W-VNMLR	2 x 8	5mm Character Height	VA Module
Specification			
Version: 1		Date: 29/09/2016	
Revision			



Pin Layout

PI	SYMBOL	DESCRIPTION	REMARKS
1	Vss	GND	
2	Vdd	Power supply for LCM	5.0V
3	NC	No Connection	
4	RS	Instruction Code	
5	R/W	Data Read / Write	
6	E	Chip Enable Signal	
7	DB0	Data bus line	
8	DB1	Data bus line	
9	DB2	Data bus line	
10	DB3	Data bus line	
11	DB4	Data bus line	
12	DB5	Data bus line	
13	DB6	Data bus line	
14	DB7	Data bus line	
15	LED+	Power Supply for BKL	
16	LED-	Power Supply for BKL	

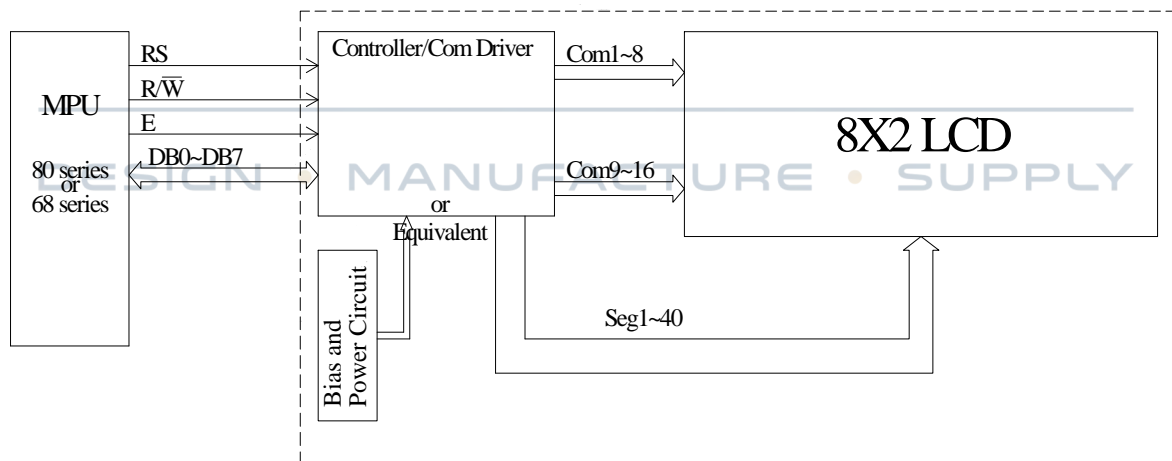

Character located	1	2	3	4	5	6	7	8
DDRAM address	00	01	02	03	04	05	06	07
DDRAM address	40	41	42	43	44	45	46	47

MC20805A12W-VNMLR	2 x 8	5mm Character Height	VA Module
Specification			
Version: 1	Date: 29/09/2016		
Revision			



Font Map

Upper 4bit Lower 4bit	LLLL	LLLH	LLHL	LLHH	LHLL	LHLH	LHHL	LHHH	HLLL	HLLH	HLHL	HLHH	HHLL	HHLH	HHHL	HHHH
LLLL	CG RAM (1)															
LLLH	(2)															
LLHL	(3)															
LLHH	(4)															
LHLL	(5)															
LHLH	(6)															
LHHL	(7)															
LHHH	(8)															
HLLL	(1)															
HLLH	(2)															
HLHL	(3)															
HLHH	(4)															
HHLL	(5)															
HHLH	(6)															
HHHL	(7)															
HHHH	(8)															

MC20805A12W-VNMLR	2 x 8	5mm Character Height	VA Module
Specification			
Version: 1		Date: 29/09/2016	
Revision			
Page 4 of 5			



Absolute Maximum Ratings

Item	Symbol	Condition	Min	Typ	Max	Unit
Power Supply (LOGIC)	Vdd	25 °C	-0.3	---	5.5	V
Power Supply (LCD)	V0	25 °C	Vss-0.3	---	Vss +7.0	V
Input Voltage	Vin	25 °C	-0.3	---	Vdd+0.3	V
Operating Temperature	Vopr	---	-20	---	70	°C
Storage Temperature	Vstg	---	-30	---	80	°C

Electronic Characteristics

Item	Symbol	Condition	Minimum	Typical	Maximum	Unit
Input Voltage High	V _{IH}	---	2.50	---	V _{DD}	V
Input Voltage Low	V _{IL}	---	-0.3	---	0.60	V
Output Voltage High	V _{OH}	---	3.90	---	Vdd	V
Output Voltage Low	V _{OL}	---	---	---	0.40	V
Supply Voltage Logic	V _{DD} - V _{SS}	---	4.50	5.00	5.50	V
Supply Voltage LCD	V _{DD} - V ₀	Ta=25°C	---	---	---	V
Supply Current	I _{DD}	V _{DD} =5.0V	1.00	1.50	2.50	mA

LCD Characteristics

For STN/FSTN LCD Panel Types						
Item	Symbol	Condition	Minimum	Typical	Maximum	Unit
Viewing Angle	Φ ₂ - Φ ₁	CR ≥ 10	---	60	---	ψ=180°
	Θ	---	---			
Contrast Ratio	CR	---	10	---	---	---
Response Time (Rise)	TR	---	---	300	350	ms
Response Time (Fall)	TF	---	---	300	350	ms

LED Characteristics

Item	Symbol	Condition	Minimum	Typical	Maximum	Unit
Supply Current	I _{LED}	V=3.5V	---	48	60	mA
Supply Voltage	V	---	2.30	2.50	2.70	V
Reverse Voltage	VR	---	---	---	5	V
Luminance (Without LCD)	IV	I _{LED} =48mA	448	560	---	Cd/m ²
Wave Length	λP	I _{LED} =48mA	620	---	630	nm
LED Life Time	---	I _{LED} =48mA	---	50K	---	Hour

MC20805A12W-VNMLR	2 x 8	5mm Character Height	VA Module
Specification			
Version: 1		Date: 29/09/2016	
Revision			

