

MC21605C6W-SPTLYI-V2	2 x 16	5mm Character Height	LCD Module
Specification			
Version: 1		Date: 20/10/2016	
Revision			

Display Features			
Character Count	2 x 16		
Appearance	Black on Yellow/Green		
Logic Voltage	5V		
Interface	I2C		
Font Set	English / Japanese		
Display Mode	Transflective		
Character Height	5.55mm		
LC Type	STN		
Module Size	80.00 x 36.00 x 13.20 mm		
Operating Temperature	-20°C ~ +70°C		
Construction	COB		
LED Backlight	Yellow/Green	Box Quantity	Weight / Display
DESIGN • MANUFACTURE • SUPPLY		---	---

* - For full design functionality, please use this specification in conjunction with the RW1063 specification. (Provided Separately)

Display Accessories	
Part Number	Description
MCCMDB-16SIL	LCD Interconnect board, can be driven from either a PC or a single Board computer with a USB output.
MCCBL1A16SLIP-16DILS-150	16 Way, Single in-line to Dual In-line connector Cable.
MCCBL1A16SLIP-16SILS-150	16 Way, Single in-line to Single In-line connector Cable.

Optional Variants		
Fonts	Appearances	Voltage
English / Russian English / European	Black on White Black on Red Black on Amber White on Blue	3V



Mechanical Specifications

Module Size	80.00 x 36.00 x 13.5 (With Backlight)				W x H x D mm
Viewing Area	66.00 x 16.00	W x H mm	Hole-to-Hole	75.00 x 31.00	W x H mm
Character Size	2.95 x 5.55	W x H mm	Character Pitch	3.55 x 5.95	W x H mm
Dot Size	0.55 x 0.65	W x H mm	Dot Pitch	0.60 x 0.70	W x H mm

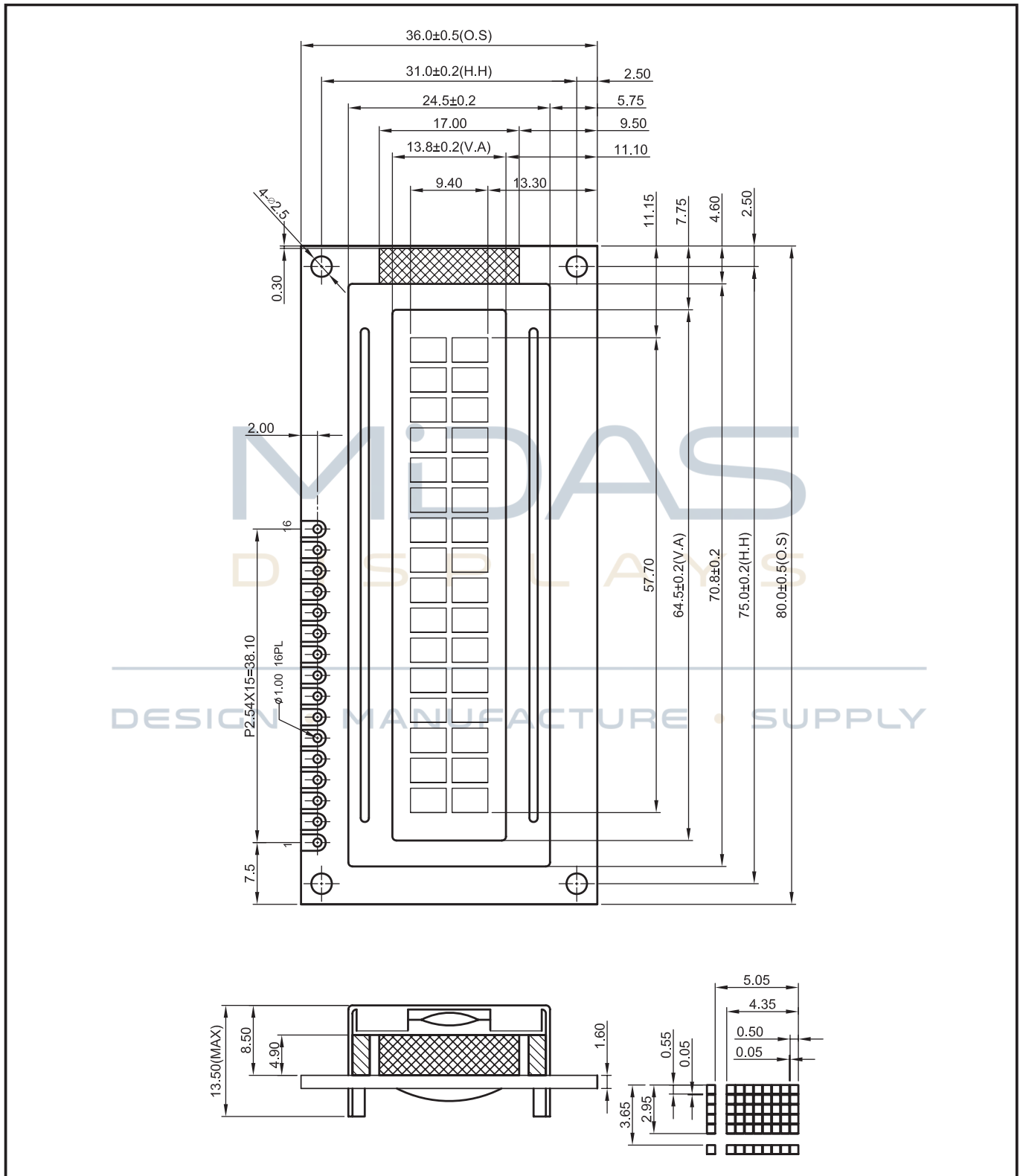

MC21605C6W-SPTLYI-V2	2 x 16	5mm Character Height	LCD Module
Specification			
Version: 1		Date: 20/10/2016	
Revision			



Pin Layout

PI	SYMBOL	DESCRIPTION	REMARKS
1	Vss	GND	
2	Vdd	Power supply for LCM	5.0V
3	V0	Operating Voltage for LCD	
4	NC	No Connection	
5	NC	No Connection	
6	NC	No Connection	
7	SA0	I2C interface, SA1 and SA0 slave	
8	SA1	address, connect to Vdd/Vss	
9	NC	No Connection	
10	NC	No Connection	
11	NC	No Connection	
12	CSB	Chip Select. Low=True High=False	
13	SDA	Serial Input Data	
14	SCL	Serial Clock Input	
15	A	Power Supply for BKL	
16	K	Power Supply for BKL	

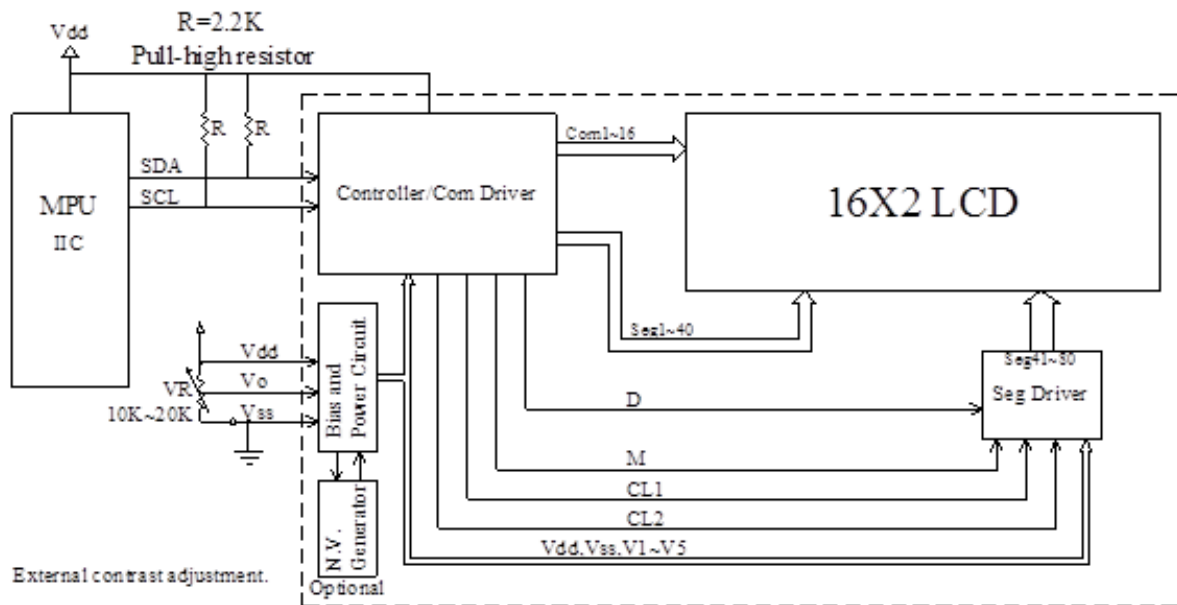

Character located	1	2	3	4	5	6	7	8	9	10	11	12	13	14	15	16
DDRAM address	00	01	02	03	04	05	06	07	08	09	0A	0B	0C	0D	0E	0F
DDRAM address	40	41	42	43	44	45	46	47	48	49	4A	4B	4C	4D	4E	4F

MC21605C6W-SPTLYI-V2	2 x 16	5mm Character Height	LCD Module
Specification			
Version: 1		Date: 20/10/2016	
Revision			



Font Map

Upper 4bit Lower 4bit	LLLL	LLLH	LLHL	LLHH	LHLL	LHLH	LHHL	LHHH	HLLL	HLLH	HLHL	HLHH	HHLL	HHLH	HHHL	HHHH
LLLL	CG RAM (1)															
LLLH	(2)															
LLHL	(3)															
LLHH	(4)															
LHLL	(5)															
LHLH	(6)															
LHHL	(7)															
LHHH	(8)															
HLLL	(1)															
HLLH	(2)															
HLHL	(3)															
HLHH	(4)															
HHLL	(5)															
HHLH	(6)															
HHHL	(7)															
HHHH	(8)															

MC21605C6W-SPTLYI-V2	2 x 16	5mm Character Height	LCD Module
Specification			
Version: 1		Date: 20/10/2016	
Revision			
Page 4 of 5			



Absolute Maximum Ratings

Item	Symbol	Condition	Min	Typ	Max	Unit
Power Supply (LOGIC)	Vdd	25°C	-0.3	---	5.5	V
Power Supply (LCD)	V0	25°C	Vss -0.3	---	Vss +7.0	V
Input Voltage	Vin	25°C	-0.3	---	Vdd +0.3	V
Operating Temperature	Vopr	---	-20	---	70	C
Storage Temperature	Vstg	---	-30	---	80	C

Electronic Characteristics

Item	Symbol	Condition	Minimum	Typical	Maximum	Unit
Input Voltage High	V _{IH}	---	2.50	---	V _{DD}	V
Input Voltage Low	V _{IL}	---	-0.30	---	0.55	V
Output Voltage High	V _{OH}	---	3.90	---	---	V
Output Voltage Low	V _{OL}	---	---	---	0.40	V
Supply Voltage Logic	V _{DD} - V _{SS}	---	4.50	5.00	5.50	V
Supply Voltage LCD	V _{DD} - V ₀	Ta=25°C	3.60	3.70	3.80	V
Supply Current	I _{DD}	V _{DD} =5.0V	1.00	1.20	1.50	mA

LCD Characteristics

For STN/FSTN LCD Panel Types						
Item	Symbol	Condition	Min	Typ	Max	Unit
Viewing Angle	Φ2 – Φ1	CR ≥ 2	40°	---	20	ψ=180°
	Θ		60°			
Contrast Ratio	K	---	---	3	---	---
Response Time (Rise)	TR	---	---	150	200	ms
Response Time (Fall)	TF	---	---	150	200	ms

LED Characteristics

Item	Symbol	Condition	Minimum	Typical	Maximum	Unit
Supply Current	I _{LED}	V=4.1V	117	130	156	mA
Supply Voltage	V	---	3.90	4.10	4.30	V
Reverse Voltage	VR	---	---	---	8	V
Luminance (Without LCD)	IV	I _{LED} =130mA	216	270	---	Cd/m ²
Wave Length	λP	I _{LED} =130mA	569	570	573	nm
LED Life Time	---	I _{LED} =130mA	---	10000K	---	Hour

Attention: It is constant current, not constant voltage, which should be applied when driving the LED backlight, please ensure you adhere to this rule.

MC21605C6W-SPTLYI-V2	2 x 16	5mm Character Height	LCD Module
Specification			
Version: 1		Date: 20/10/2016	
Revision			
			Page 5 of 5