

MCCOG240064A16W-BNMLW (2)	240 x 64	LCD Module
<b>Specification</b>		
Version: 1	Date: 08/05/2021	
<b>Revision</b>		
1	06/05/2021	First Issue

Display Features			
Resolution	240 x 64		
Appearance	White on Blue		
Logic Voltage	3V		
Interface	SPI		
Font Set	N/A		
Display Mode	Transmissive		
LC Type	Blue STN		
Module Size	120.00 x 44.82 x 5.50mm		
Operating Temperature	-20°C ~ +70°C		
Construction	COG	Box Quantity	Weight / Display
LED Backlight	White	---	---

\* - For full design functionality, please use this specification in conjunction with the ST7565P specification. (Provided Separately)

Display Accessories	
Part Number	Description

Optional Variants	
Appearances	Voltage



## **FUNCTIONS & FEATURES**

- Viewing Direction : 6 O'clock
- Driving Scheme : 1/65 Duty, 1/7Bias
- Power Supply Voltage : 3.0V
- LCD Operation Voltage : 8.0V
- Display Contents : 240\*64 dots
- Interface : SPI Interface
- Operating temperature : -20°C ~ +70°C
- Storage temperature : -30°C ~ +80°C

## **MECHANICAL SPECIFICATIONS**

- Module Size : 120.00 (L)mm x 194.82 (W)mm x 5.50(T)mm
- Viewing Area : 102.40 mm x 30.22 mm
- Active Area : 98.38 mm x 26.22 mm
- Dot Size : 0.39 (W)mm x 0.39 (H) mm
- Dot Gap : 0.02 mm

MIDAS  
DISPLAYS

---

DESIGN • MANUFACTURE • SUPPLY



**EXTERNAL DIMENSIONS**

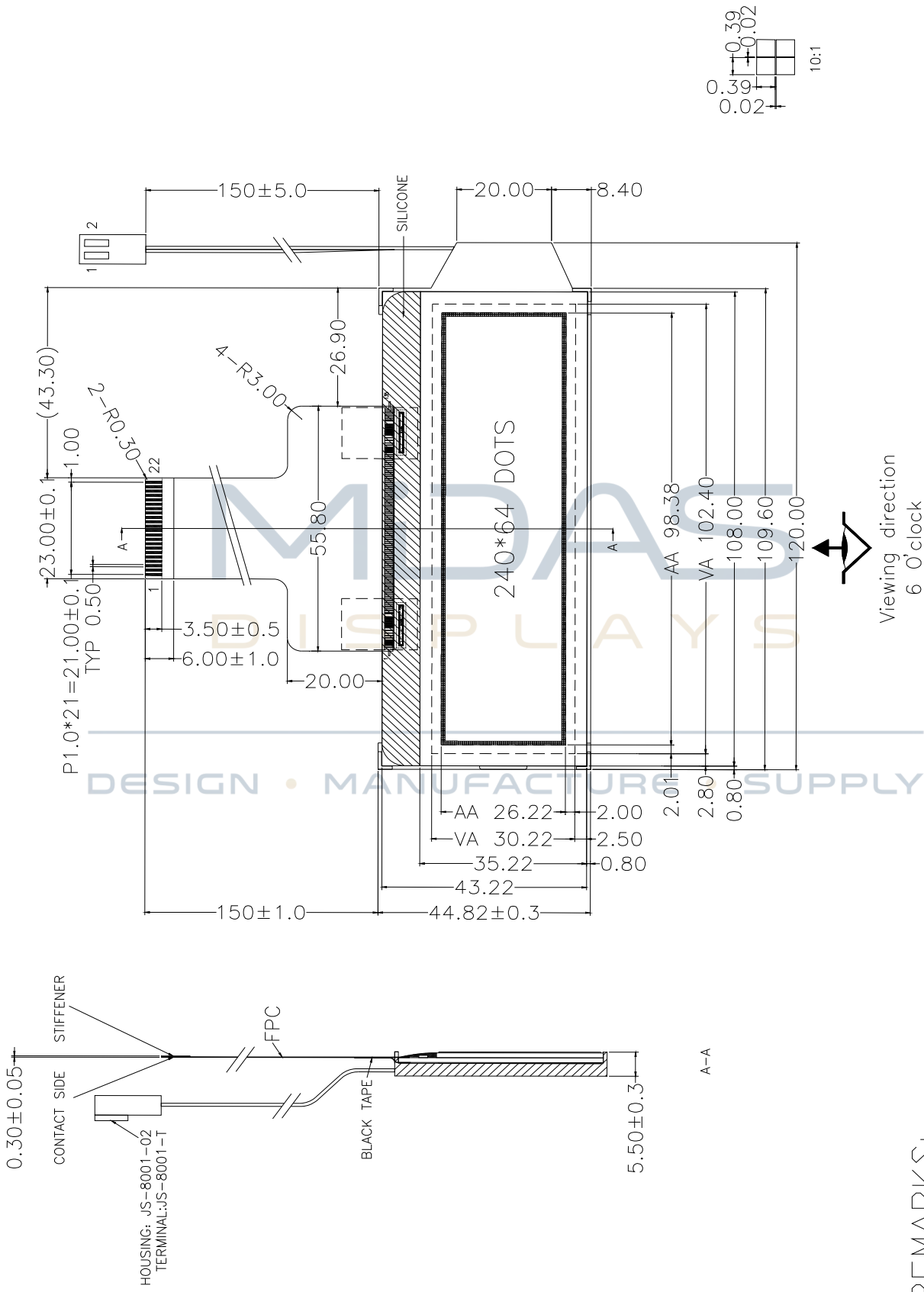

REMARKS:  
 1, UNMARKED TOLERANCE IS ±0.3.  
 2, THE MATERIAL COMPLY WITH ROHS.

# BLOCK DIAGRAM

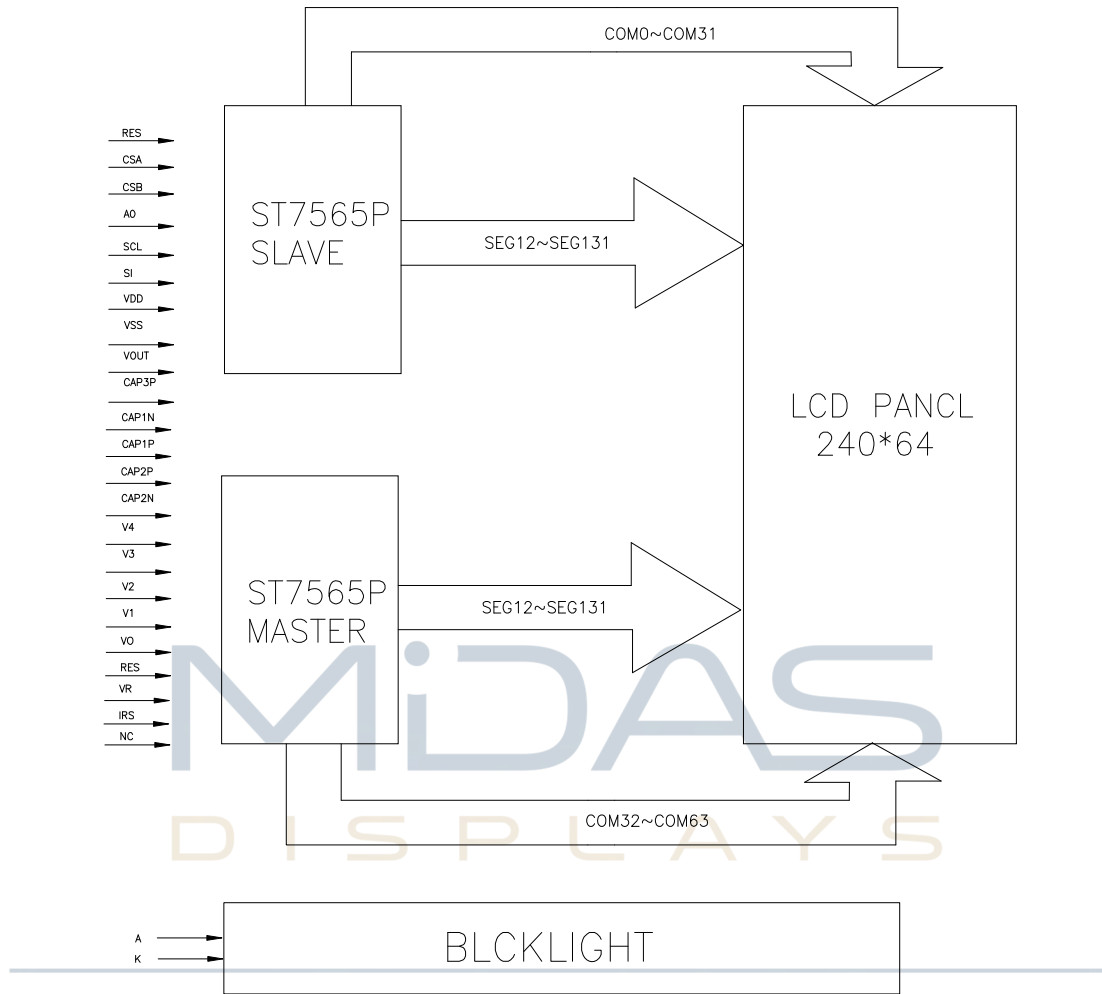

DESIGN • MANUFACTURE • SUPPLY



## PIN DESCRIPTION

Pin No.	Name	Description
1	RES	Hardware reset input pin. When RSTB is "L", internal initialization is executed and the internal registers will be initialized.
2	CSA	This is the chip select signal for Master driver .WhenCSA=Low then the chip select becomes active ,and data/command I/O is enabled
3	CSB	This is the chip select signal for Master driver .WhenCSB=Low then the chip select becomes active ,and data/command I/O is enabled
4	A0	It determines whether the access is related to data or command. A0="H": Indicates that signals on D[7:0] are display data. A0="L": Indicates that signals on D[7:0] are command.
5	SCL	Serial clock input terminal.
6	SI	Serial data input terminal.
7	VDD	Digital power. If VDD=VDD2, connect to VDD2 externally.
8	VSS	Ground of chip.
9	VOUT	DC-DC voltage converter for LCD driver circuit. Connect a capacitor between VOUT and VSS.
10	CAP3P	DC-DC voltage converter for LCD driver circuit. If using built-in voltage booster circuit, the application circuit please refers to section of Liquid Crystal Driver Power Circuit.
11	CAP1N	
12	CAP1P	
13	CAP2P	
14	CAP2N	
15	V4	The power supply pins for LCD. Insure the voltage levels of VOUT, V0, V1, V2, V3 and V4 always match below relation: VOUT > V0 > V1 > V2 > V3 > V4 > VSS
16	V3	
17	V2	
18	V1	
19	V0	
20	VR	If using external resistance for V0 voltage regulator, this pin is provided to connect external resistor for voltage divide.
21	IRS	This pin selects built-in resistor for V0 adjustment is enable or disable. IRS="H": built-in resistor is enabled. IRS="L": built-in resistor is disabled.
22	NC	No connection.

# BACKLIGHT ELECTRICAL/OPTICAL SPECIFICATIONS

Item	Symbol	min.	typ.	max.	Unit	Condition
Forward Current	I <sub>v</sub>	3.8	4.0	4.2	v	I <sub>f</sub> =30 mA
Power Dissipation	P <sub>d</sub>		120		mW	I <sub>f</sub> =30 mA
Luminous Uniformity	DL <sub>v</sub>	70			%	MIN/MAX*100%
Luminance	L <sub>v</sub>	-	360	-	cd/m <sup>2</sup>	I <sub>f</sub> =30 mA T=25°C
Color Coordinate	X	0.25		0.33		
	Y	0.25		0.33		

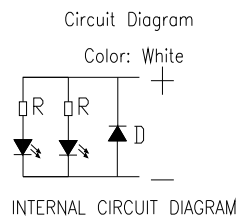
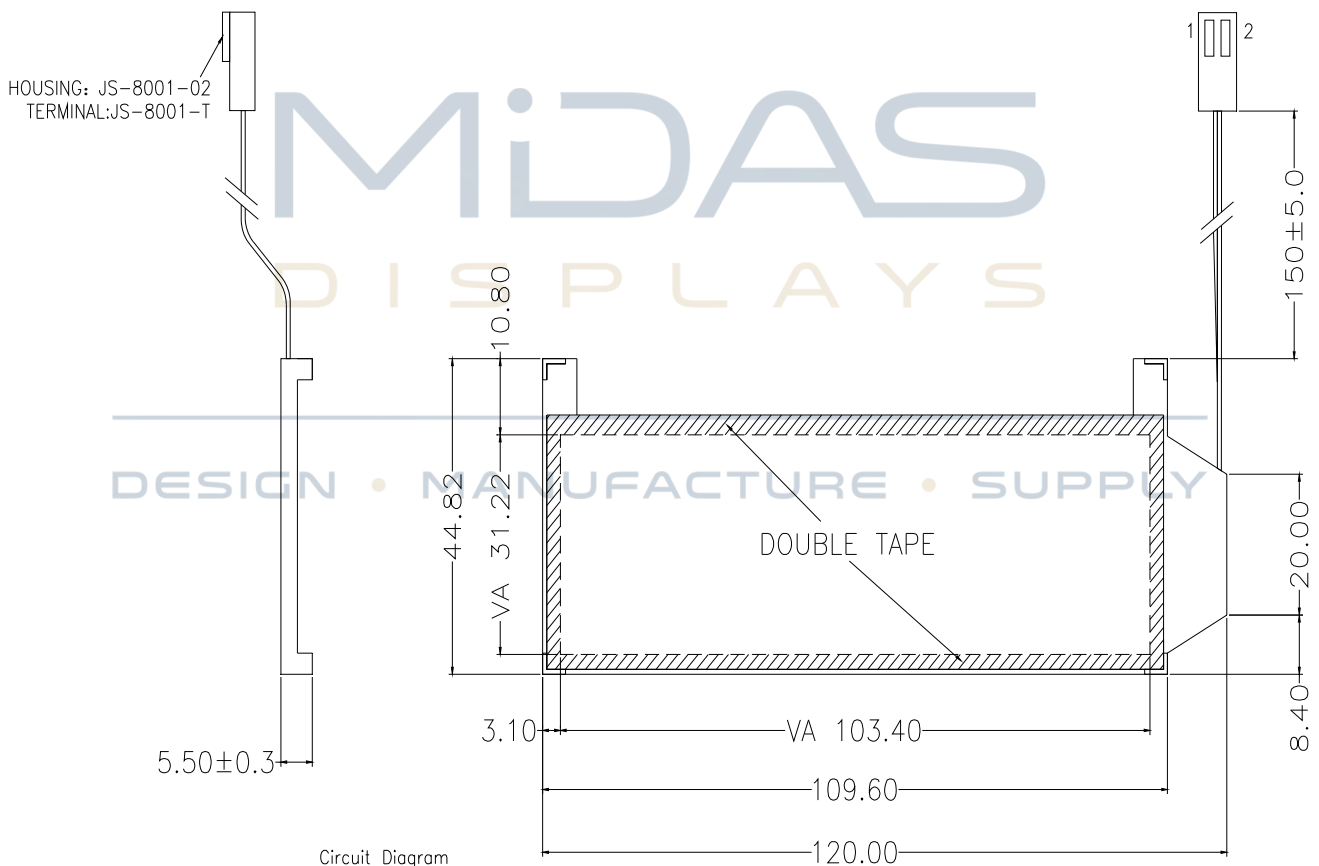

## MAXIMUM ABSOLUTE LIMIT

Characteristic	Symbol	value	Unit
Power supply voltage	VDD	-0.3 ~ +3.3	V
LCD Driver Voltage	Vout,V0	-0.3 ~+8.3	V
Input voltage	V1,V2,V3,V4	-0.3 ~ V0	V
Operating temperature	Topr	-20 ~ +70	°C
Storage temperature	Tstg	-30 ~ +80	°C

## ELECTRICAL CHARACTERISTICS

### 1. DC Characteristics

Item	Symbol	Min	Typ	Max	Condition	Unit	Remark
Operating voltage	V <sub>DD</sub>	2.7	3.0	3.3		V	
LCD driving voltage	V <sub>LCD</sub>	7.7	8.0	8.3	-	V	
Operating current	I <sub>DD</sub>	---	TBD	---		mA	

### 2. AC Characteristics

#### System Bus Timing for 4-Line Serial Interface

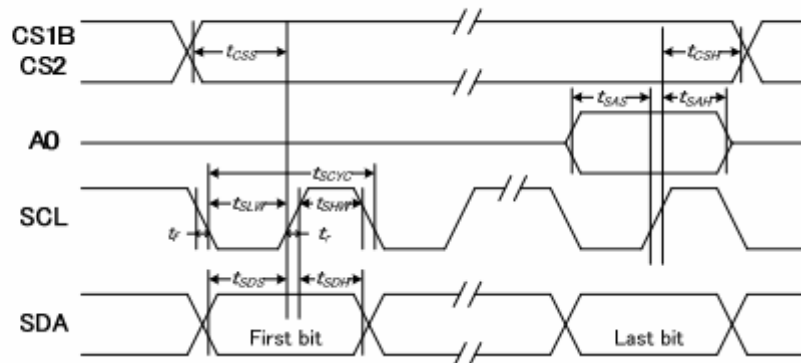

Item	Signal	Symbol	Condition	Min.	Max.	Unit
Serial clock period	SCLK	tSCYC		100	—	ns
SCLK "H" pulse width		tSHW		50	—	
SCLK "L" pulse width		tSLW		50	—	
Address setup time	A0	tSAS		30	—	
Address hold time		tSAH		20	—	
Data setup time	SDA	tSDS		30	—	
Data hold time		tSDH		20	—	
CS-SCLK time	CS1B	tCSS		30	—	
CS-SCLK time	CS2	tCSH		60	—	

# INSTRUCTION DESCRIPTION

## Instruction Set

INSTRUCTION	A0	R/W (RWR)	COMMAND BYTE								DESCRIPTION
			D7	D6	D5	D4	D3	D2	D1	D0	
Display ON/OFF	0	0	1	0	1	0	1	1	1	D	D=1, display ON D=0, display OFF
Set Start Line	0	0	0	1	S5	S4	S3	S2	S1	S0	Set display start line
Set Page Address	0	0	1	0	1	1	Y3	Y2	Y1	Y0	Set page address
Set Column Address	0	0	0	0	0	1	X7	X6	X5	X4	Set column address (MSB)
	0	0	0	0	0	0	X3	X2	X1	X0	Set column address (LSB)
Read Status	0	1	BUSY	MX	D	RST	0	0	0	0	Read IC Status
Write Data	1	0	D7	D6	D5	D4	D3	D2	D1	D0	Write display data to RAM
Read Data	1	1	D7	D6	D5	D4	D3	D2	D1	D0	Read display data from RAM
SEG Direction	0	0	1	0	1	0	0	0	0	MX	Set scan direction of SEG MX=1, reverse direction MX=0, normal direction
Inverse Display	0	0	1	0	1	0	0	1	1	INV	INV =1, inverse display INV =0, normal display
All Pixel ON	0	0	1	0	1	0	0	1	0	AP	AP=1, set all pixel ON AP=0, normal display
Bias Select	0	0	1	0	1	0	0	0	1	BS	Select bias setting 0=1/9; 1=1/7 (at 1/65 duty)
Read-modify-Write	0	0	1	1	1	0	0	0	0	0	Column address increment: Read:+0 , Write:+1
END	0	0	1	1	1	0	1	1	1	0	Exit Read-modify-Write mode
RESET	0	0	1	1	1	0	0	0	1	0	Software reset
COM Direction	0	0	1	1	0	0	MY	-	-	-	Set output direction of COM MY=1, reverse direction MY=0, normal direction
Power Control	0	0	0	0	1	0	1	VB	VR	VF	Control built-in power circuit ON/OFF
Regulation Ratio	0	0	0	0	1	0	0	RR2	RR1	RR0	Select regulation resistor ratio
Set EV	0	0	1	0	0	0	0	0	0	1	Double command!! Set electronic volume (EV) level
	0	0	0	0	EV5	EV4	EV3	EV2	EV1	EV0	
Power Save	0	0	Compound Command								Display OFF + All Pixel ON
Set Booster	0	0	1	1	1	1	1	0	0	0	Double command!! Set booster level: BL[1:0]=(0,0), x2, x3, x4
	0	0	0	0	0	0	0	0	BL1	BL0	BL[1:0]=(0,1), x5 BL[1:0]=(1,1), x6
NOP	0	0	1	1	1	0	0	0	1	1	No operation
Test	0	0	1	1	1	1	-	-	-	-	Do NOT use. Reserved for testing.

Note: Symbol "-" means this bit can be "H" or "L".





# LCD LAYOUT

## 11. ARTWORK

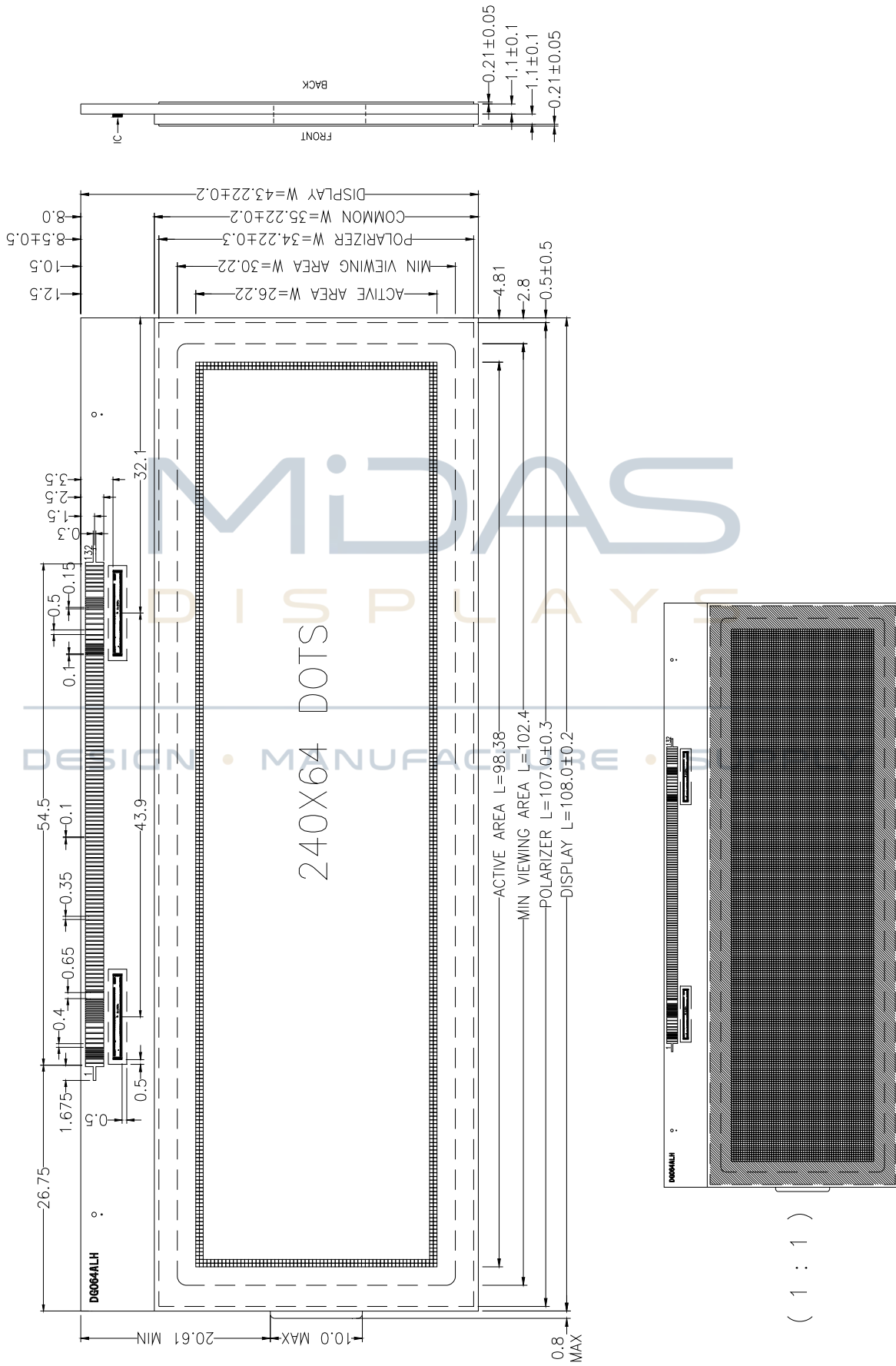

## 2. Labeling

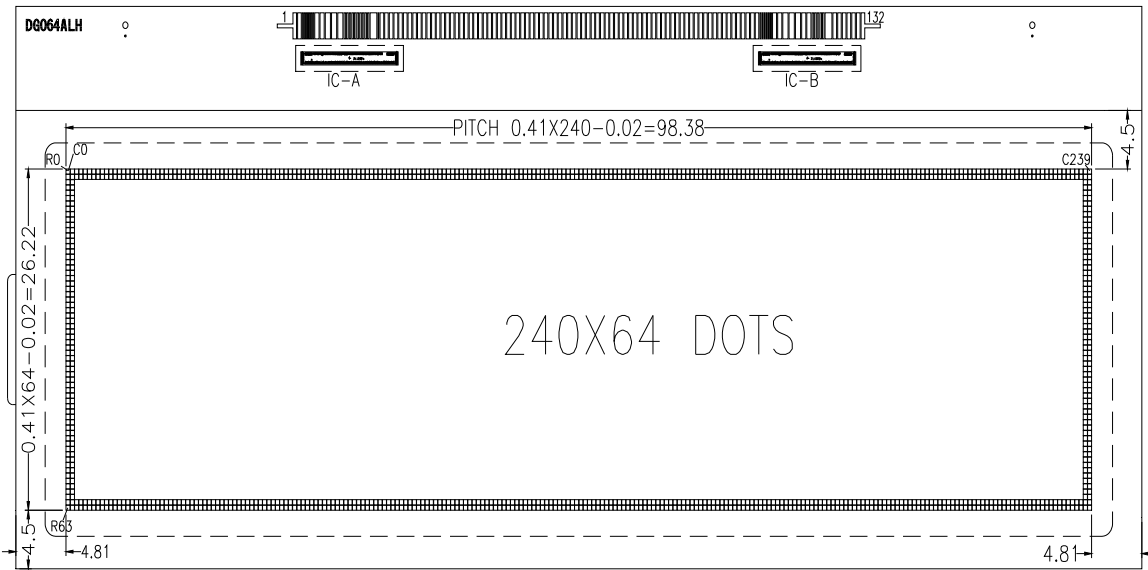

## 3. SEG&COM LAYOUT

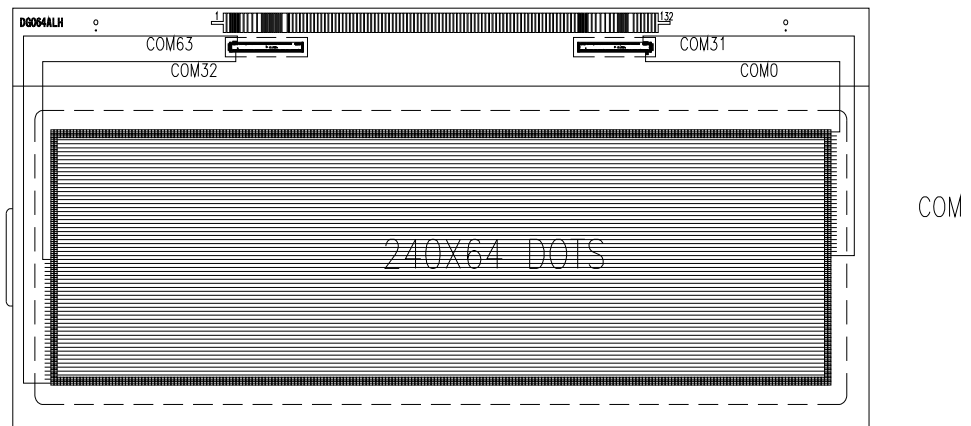
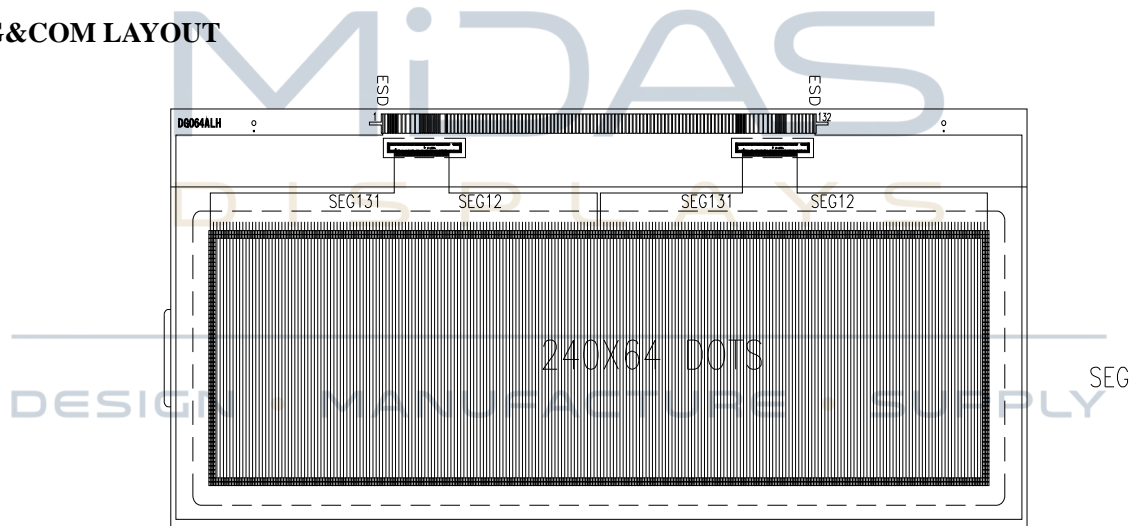

# PAD CONFIGURATION GRAPHIC DIMENSION

IC-A		IC-B	
IC NO.	PAD CONFIGURATION	IC NO.	PAD CONFIGURATION
COM63	COM63[R63(CO-C239)]	SEG131	SEG131[C120(R0-R63)]
COM62	COM62[R62(CO-C239)]	SEG130	SEG130[C121(R0-R63)]
COM33	COM33[R33(CO-C239)]	SEG13	SEG13[C238(R0-R63)]
COM32	COM32[R32(CO-C239)]	SEG12	SEG12[C239(R0-R63)]
SEG131	SEG131[CO(R0-R63)]	COM0	COM0[RO(CO-C239)]
SEG130	SEG130[C1(R0-R63)]	COM1	COM1[R1(CO-C239)]
SEG13	SEG13[C118(R0-R63)]	COM30	COM30[R30(CO-C239)]
SEG12	SEG12[C119(R0-R63)]	COM31	COM31[R31(CO-C239)]

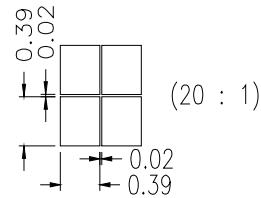

UNLESS OTHERWISE SPECIFIED  
DIMENSIONS ARE IN MM  
TOLERANCES: ±0.1MM

## IC LAYOUT

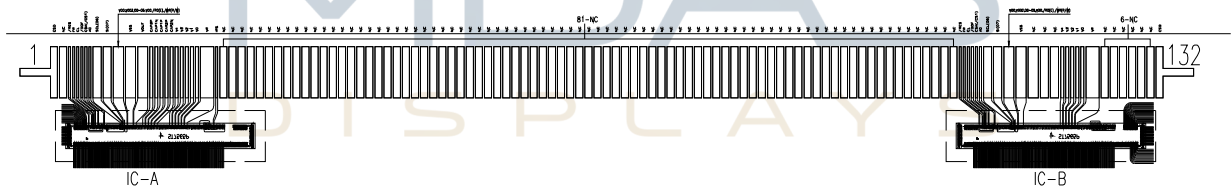

## IC NO. CONFIGURATION PAD CONFIGURATION

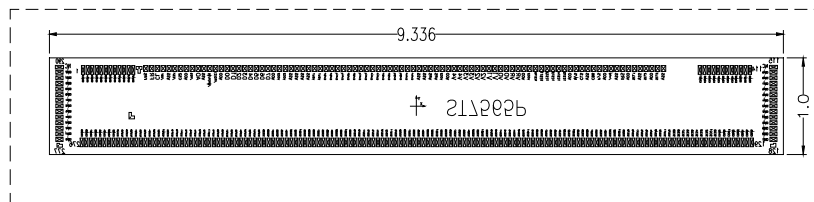

PAD NO.	PAD CONFIGURATION
1	ESD
2	NC
3	/RES
4	FR
5	CL
6	/DOF
7	CSM(CS1)
8	AO
9	SCL(D6)
10	SI(D7)
11	VSS
12	VSS
13	VOUT
14	CAP3P
15	CAP1N
16	CAP1P
17	CAP2P
18	CAP2N
19	V4
20	V3
21	V2
22	V1
23	V0
24	VR
25	IRS
26-106	NC

PAD NO.	PAD CONFIGURATION
107	/RES
108	FR
109	CL
110	/DOF
111	CSM(CS1)
112	AO
113	SCL(D6)
114	SI(D7)
115	VSS
116	VSS
117	NC
118	NC
119	NC
120	V4
121	V3
122	V2
123	V1
124	V0
125	VR
126-131	NC
132	ESD

## MODULE ACCEPT QUALITY LEVEL (AQL)

Inspection Plan: ANSI Z-1.4, Normal Inspection Level II, Single Sampling Plan.

## RELIABILITY TEST

Operating life time: Longer than 50000 hours

(at room temperature without direct irradiation of sunlight)

Reliability characteristics shall meet following requirements.

TEMPERATURE TESTS	NORMAL GRADE
High temperature storage	+80°C x 96hrs
Low temperature storage	-30°C x 96hrs
High temperature operation	+70°C x 96hrs
Low temperature operation	-20°C x 96hrs
High temperature, High humidity	+60°C x 90%RH x 96hrs
Thermal shock	-20°C x 30min 10s ↓ 5Cycles +70°C x 30min
Vibration test	Frequency x Swing x Time 40Hz x 4mm x 4hrs
Drop test	Drop height x Times 1.0m x 6times

## QUALITY DESCRIPTION & APPLICATION NOTE

Please refer to "General Inspection Criteria" document

---

DESIGN • MANUFACTURE • SUPPLY