

MCT0096A0W80160PMLIPS	80 x 160	SPI Interface	TFT Module
Specification			
Version: 1		Date: 09/04/2018	
Revision			
1	28/08/2017	First Issue.	

Display Features					
Display Size	0.96"				
Resolution	80 x 160				
VGA Size	N/A				
Orientation	Portrait				
Appearance	RGB				
Logic Voltage	2.8V				
Interface	4-Line SPI				
Brightness	320 cd/m ²				
Touchscreen	N/A				
Module Size	13.30 x 27.948 x 1.40 mm				
Operating Temperature	-20°C ~ +70°C			Box Quantity	Weight / Display
Pinout	13 - Way FFC			---	---

* - For full design functionality, please use this specification in conjunction with the ST7735S specification. (Provided Separately)

Display Accessories	
Part Number	Description
LEDV3	Constant current LED back light driver.

Optional Variants	
Appearances	Voltage



1. Scope

This data sheet is to introduce the specification of MCT0096A0W80160PMLIPS active matrix TFT module. It is composed of a color TFT-LCD panel, driver IC, FPC and a backlight unit. The 0.96" display area contains 80 (RGB) x 160 pixels.

2. Application

Digital equipments which need color display, mobile navigator/video systems.

3. General Information

Item	Contents	Unit
Size	0.96	inch
Resolution	80 (RGB) x 160	/
Interface	4-Line SPI Interface	/
Technology type	IPS	/
Pixel pitch	0.135 x 0.135	mm
Pixel Configuration	R.G.B. Vertical Stripe	
Outline Dimension (W x H x D)	13.30 x 27.948 x 1.40	mm
Active Area	10.80 x 21.696	mm
Display Mode	Transmissive	/
Driver IC	ST7735S	
Viewing Direction	Free	
Backlight Type	LED	/
Weight	TBD	g



5. Interface signals

No.	Symbol	Description
1	TP0	Touch Pin, If not used, Please open this pin.
2	TP1	Touch Pin, If not used, Please open this pin.
3	SDA	SPI interface input/output pin. The data is latched on the rising edge of the SCL signal.
4	SCL	This pin is used to be serial interface clock.
5	D/C	Display data/command selection pin in 4-line serial interface.
6	RESET	This signal will reset the device and it must be applied to properly initialize the chip. Signal is active low.
7	CS	Chip selection pin, Low enable, High disable.
8	GND	Power Ground
9	NC	Not Connect
10	VDD	Power Supply for Analog, VDD=2.5V~3.3V.
11	LEDK	LED Cathode
12	LEDA	LED Anode
13	GND	Power Ground

6. Absolute maximum Ratings

6.1. Electrical Absolute max. ratings

Parameter	Symbol	MIN	MAX	Unit	Remark
Supply Voltage	VDD	-0.3	4.8	V	

6.2. Environment Conditions

Item	Symbol	MIN	MAX	Unit	Remark
Operating Temperature	TOPR	-20	70	°C	
Storage Temperature	TSTG	-30	80	°C	

6.3. LED Backlight Absolute max. ratings

Item	Symbol	MIN	MAX	Unit	Remark
LED Forward Current	ILED	--	25	mA	One LED



7. Electrical Specifications

7.1 Electrical characteristics

Ta=25°C

Item	Symbol	Unit	Condition	Min	Typ	Max	Note
Power and Operation Voltage							
Analog Operating Voltage	VDD	V	Operation Voltage	2.5	2.8	3.3	Note2
Logic Operating Voltage	VDDIO	V	I/O Supply Voltage	1.65	2.8	3.3	Note2
Digital Operating Voltage	VCORE	V	Digital Supply Voltage	-	1.5	-	Note2
Driver Supply Voltage	-	V	-	-	-	32	Note3
Input and output							
Logic Hight level input voltage	VIH	V	-	0.7*VDDI	-	VDDI	Note1,2,3
Logic Low level input voltage	VIL	V	-	VSS	-	0.3*VDDI	Note1,2,3
Logic Hight level output voltage	VOH	V	IOL=1.0mA	0.8*VDDI	-	VDDI	Note1,2,3
Logic Low level output voltage	VOL	V	IOL=1.1mA	VSS	-	0.2*VDDI	Note1,2,3
Logic Hight level input Current	IIH	uA	-	-	-	1	Note1,2,3
Logic Low level input Current	IIL	uA	-	-1.0	-	-	Note1,2,3
Logic input Leakage Current	ILEA	uA	VIN=VDDI or VSS	-0.1	-	0.1	Note1,2,3

Notes:

1: VDDIO=1.65 to 3.3V,VDD=2.5 to 3.3V,AGND=VSS=0V,Ta=-30 to 70(to +85 no damage)°C

2: Please supply digital VDDIO voltage equal or less than analog VDD voltage.

3: CSX,RDX,WRX,D[17:0],D/CX,RESX,TE,DOTCLK,VSYN,HSYN,DE,SDA,SCL,IM3,IM2,IM1,IM0,and Test pins.

7.2 LED Backlight

Ta=25°C

Item	Symbol	MIN	TYP	MAX	Unit	Remark
Forward Current	IF	-	15	-	mA	-
Forward Voltage	VF	-	3.0	-	V	
LED Power Consumption	PLED	-	45	-	mW	Note

Note : Calculator Value for reference ILED×VLED×LED Quantity= PLED

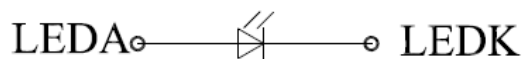

LED CIRCUIT DIAGRAM

VF=3V IF=15mA

7.3. Backlight Recommended Circuit

Motherboard driver backlight is need constant current circuit, if the rated voltage screen after light brightness difference. Current and power consumption of the machine are inconsistent, so recommend a backlight driving circuit is best rated current. It is recommended to use IC (AW9364). The reference circuit is as follows,

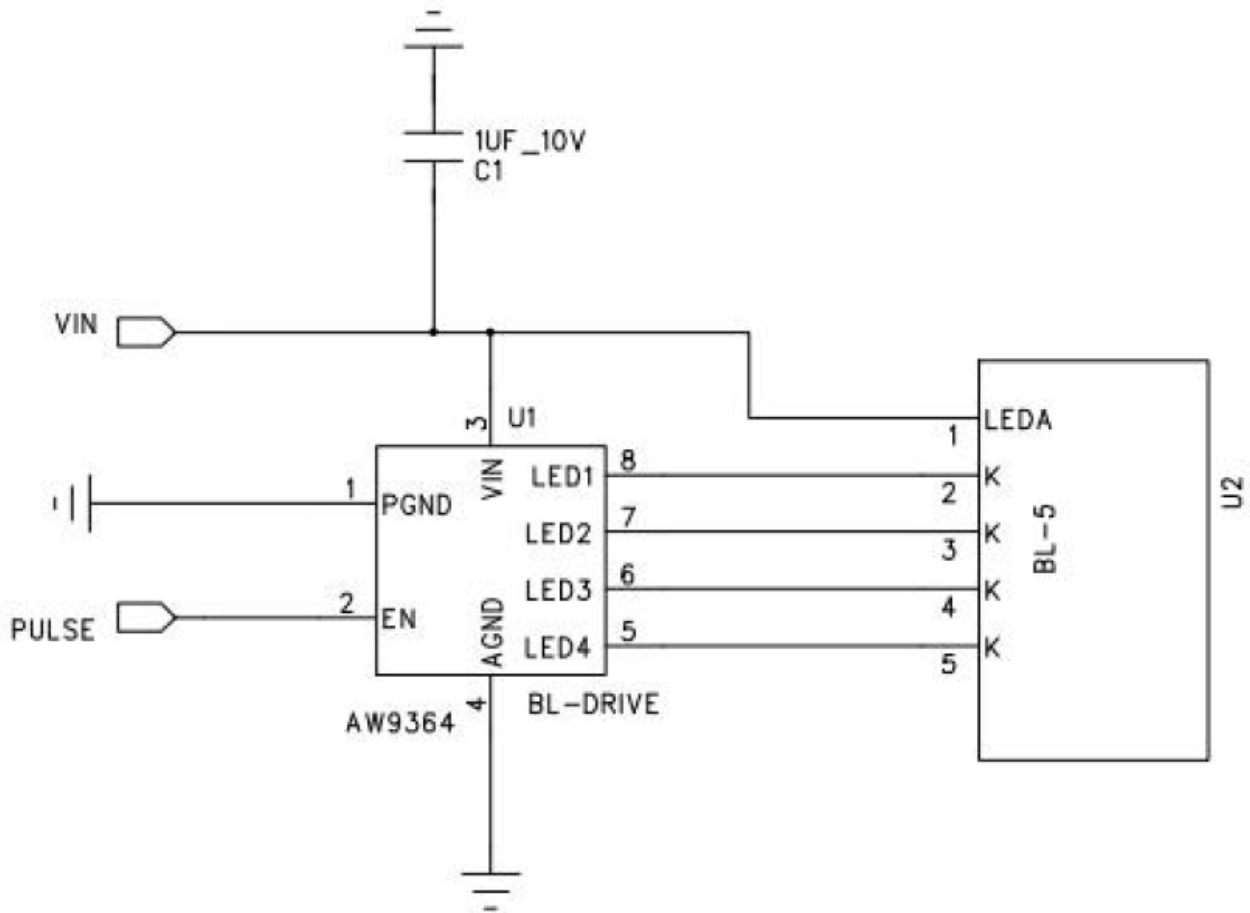

DESIGN • MANUFACTURE • SUPPLY



8. Command/AC Timing

Serial Interface Characteristics (4-line serial)

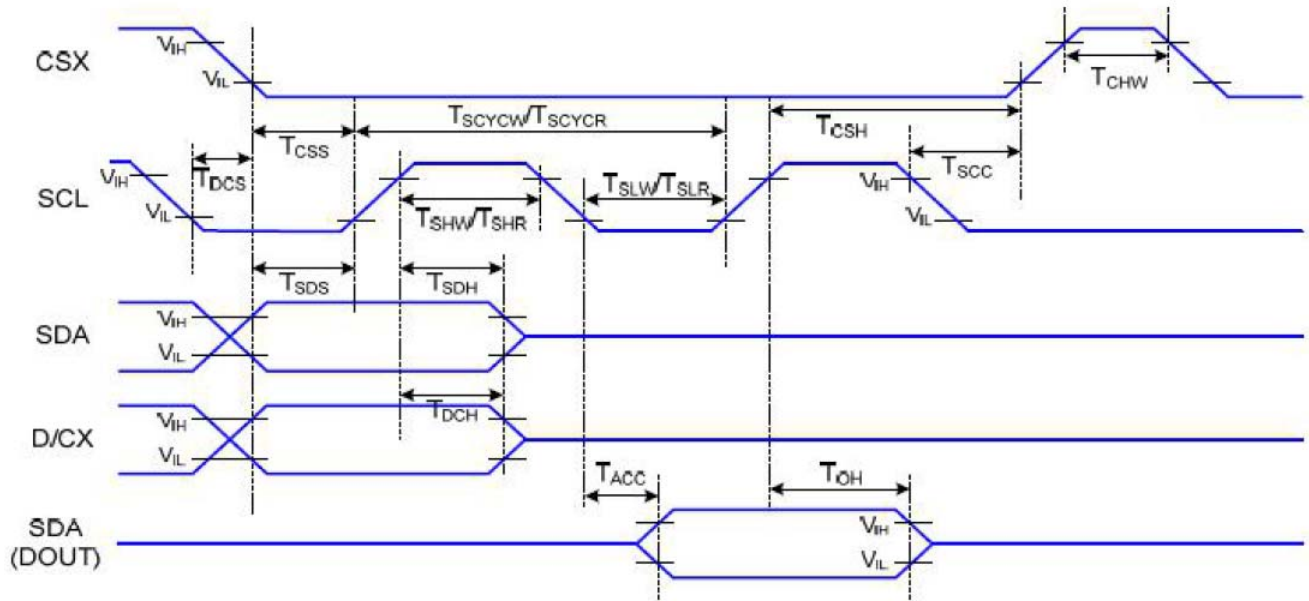

4-line serial Interface Timing Characteristics

(VDDIO=1.65 to 3.3V, VDD=2.4 to 3.3V, AGND=DGND=0V, Ta= -30 to 70°C)

Signal	Symbol	Parameter	Min	Max	Unit	Description
CSX	TCSS	Chip select setup time (Write)	45		ns	
	TCSH	Chip select hold time (Write)	45		ns	
	TCSS	Chip select setup time (Read)	60		ns	
	TSCC	Chip select hold time (Read)	65		ns	
	TCHW	Chip select "H" pulse width	40		ns	
SCL	TSCYCW	Serial clock cycle (Write)	66		ns	-Write Command & Data Ram
	TSHW	SCL "H" pulse width (Write)	15		ns	
	TSLW	SCL "L" pulse width (Write)	15		ns	
	TSCYCR	Serial clock cycle (Read)	150		ns	-Read Command & Data Ram
	TSHR	SCL "H" pulse width (Read)	60		ns	
	TSLR	SCL "L" pulse width (Read)	60		ns	
D/CX	TDCS	D/CX setup time	10		ns	
	TDCH	D/CX hold time	10		ns	
SDA (DIN) (DOUT)	TSDS	Data setup time	10		ns	For Maximum CL=30Pf For Minimum CL=8pF
	TSDH	Data hold time	10		ns	
	TACC	Access time	10	50	ns	
	TOH	Output disable time	15	50	ns	

9. Optical Specification

Ta=25°C

Item	Symbol	Condition	Min	Typ.	Max.	Unit	Remark
Contrast Ratio	CR	$\theta=0^\circ$	TBD	TBD	-		Note1 Note2
Response Time	Ton/ Toff	25°C	-	35	50	ms	Note1 Note3
Threshold Voltage	Vsat		4.1	4.3	4.5	V	Note4
	Vth		1.6	1.8	2.0	V	
View Angles	θT	$CR \geq 10$	-	80	-	Degree	Note6
	θB		-	80	-		
	θL		-	80	-		
	θR		-	80	-		
Chromaticity	White	x		TBD		Note7, Note1	
		y		TBD			
	Red	x	Brightness is on	0.610	0.625		0.640
		y		0.295	0.310		0.325
	Green	x		0.280	0.295		0.310
		y		0.503	0.518		0.533
	Blue	x		0.127	0.142		0.157
		y		0.128	0.143		0.158
NTSC	S			50		%	Note7
Transmittance	%	$\theta=0^\circ$	4.1	4.59			Note5
Luminance	L		300	320	350	cd/m ²	Note1 Note8
Uniformity	U			TBD		%	Note1 Note9



Note 1: Definition of optical measurement system.

Temperature = 25°C(±3°C)

LED back-light: ON, Environment brightness < 150 lx

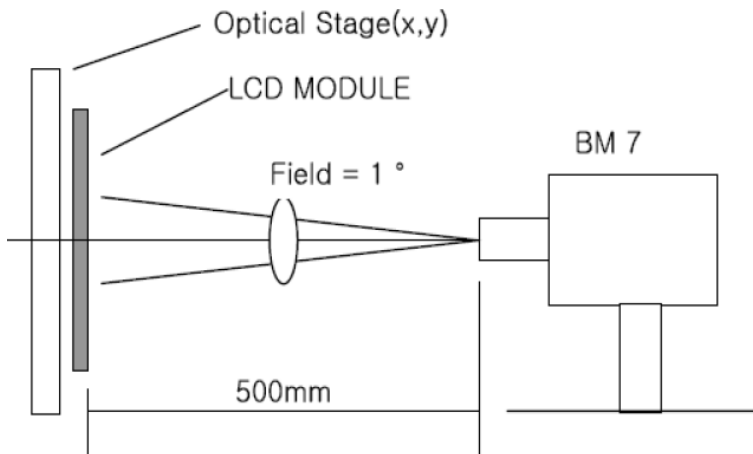

Note 2: Contrast ratio is defined as follow:

$$\text{Contrast Ratio} = \frac{\text{Surface Luminance with all white pixels}}{\text{Surface Luminance with all black pixels}}$$

Note 3: Response time is defined as follow:

Response time is the time required for the display to transition from black to white (Rise Time, Tr) and from white to black(Decay Time, Tf).

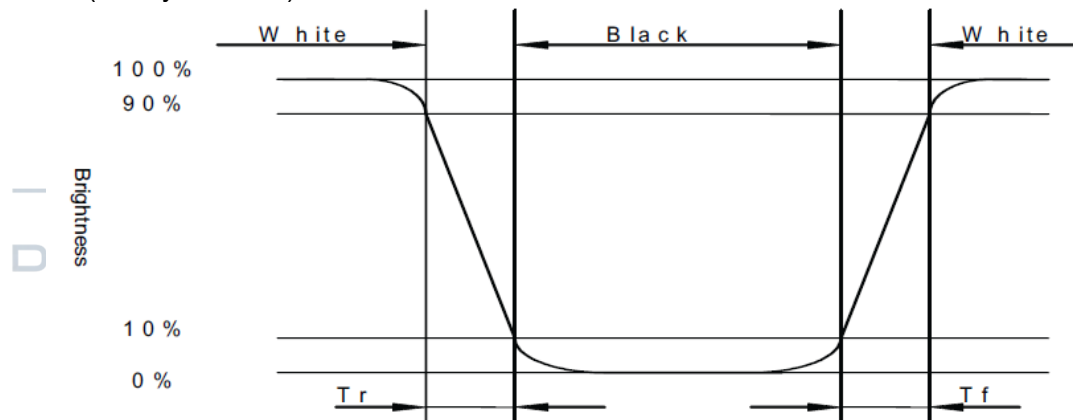

Note 4:

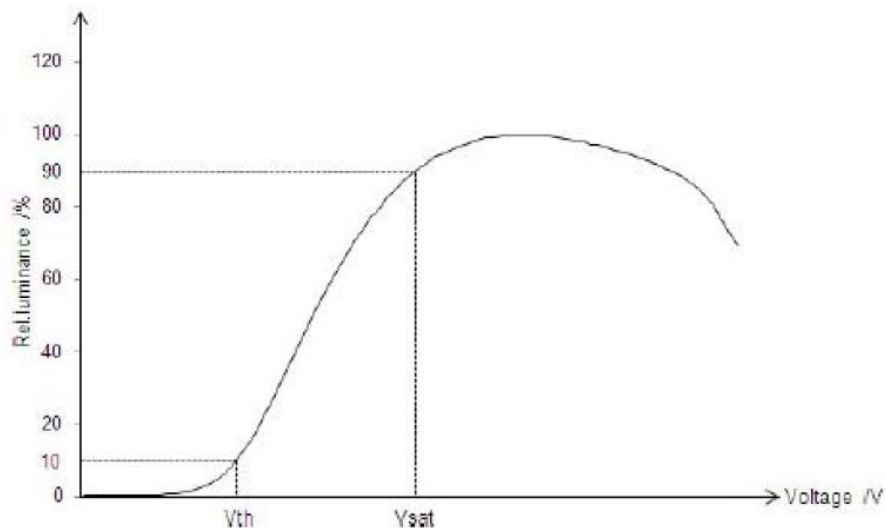

Note 5 : Surface luminance is the center point across the LCD surface 50cm from the surface with all pixels displaying white. This measurement shall be taken at the locations shown in FIG as follow:

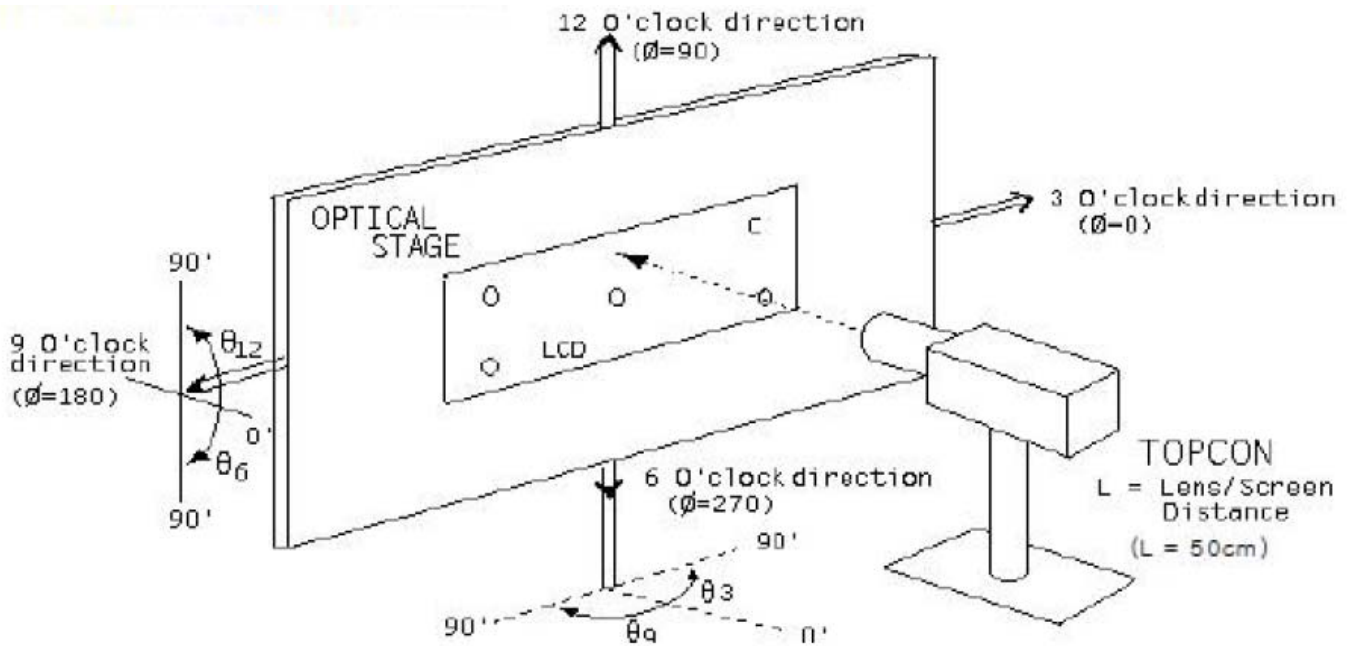

Note 6: Viewing angle range is defined as follow:

Viewing angle is measured at the center point of the LCD.

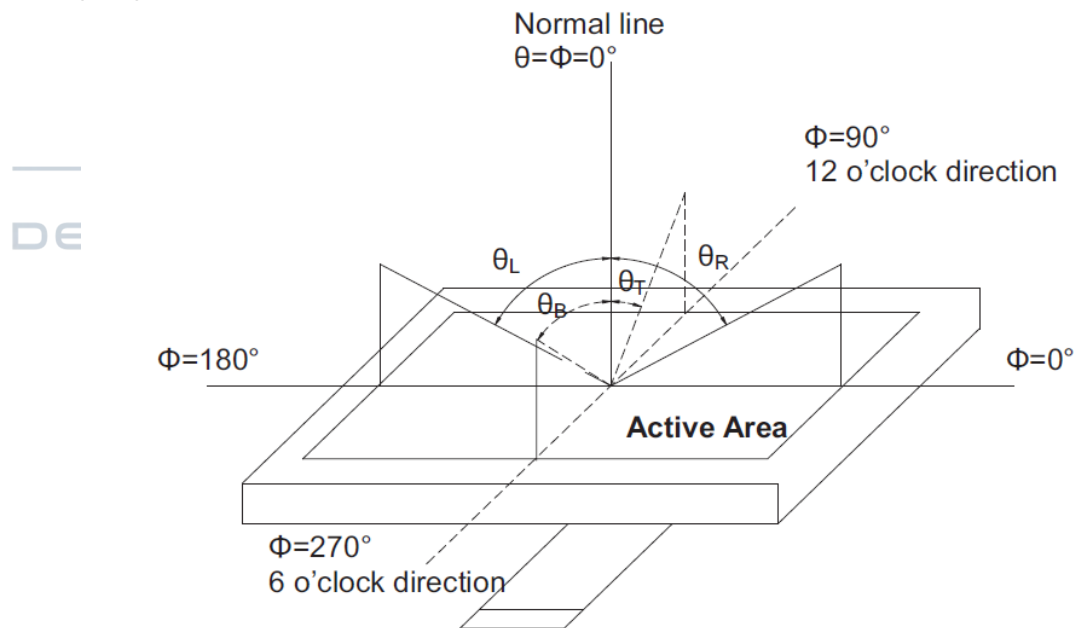

Note 7: Color chromaticity is defined as follow: (CIE1931)

Color coordinates measured at center point of LCD.

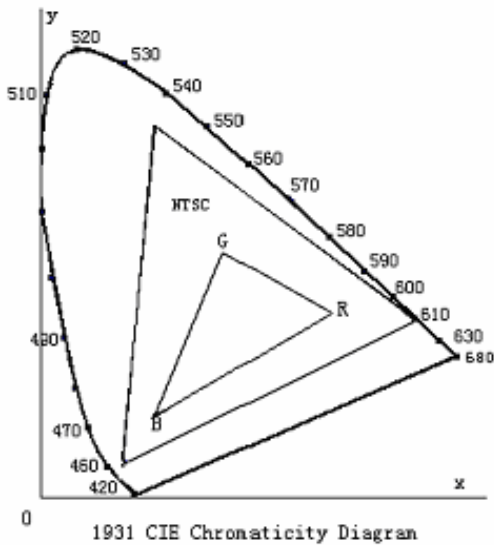

$$S = \frac{\text{area of RGB triangle}}{\text{area of NTSC triangle}} \times 100\%$$

Note 8: Luminance is defined as follow:

Luminance is defined as the brightness of all pixels “White” at the center of display area on optimum contrast.

Note 9: Luminance Uniformity is defined as follow:

Active area is divided into 9 measuring areas (Refer Fig. 2). Every measuring point is placed at the center of each measuring area.

$$\text{Uniformity (U)} = \frac{\text{Minimum Luminance(brightness) in 9 points}}{\text{Maximum Luminance(brightness) in 9 points}}$$

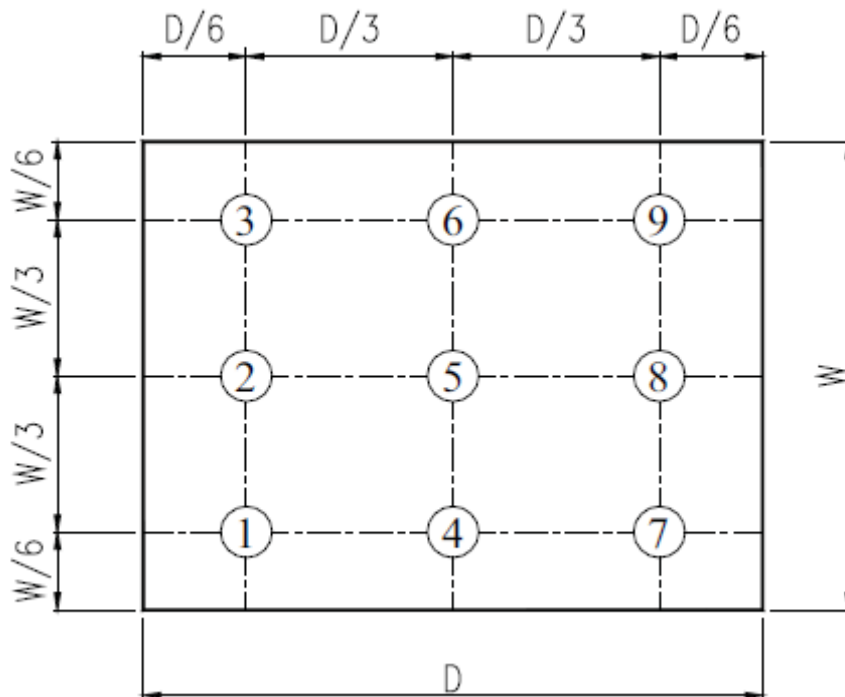

Fig. 2 Definition of uniformity

—
D P L Y



10. Environmental / Reliability Tests

No	Test Item	Condition	Judgment criteria
1	High Temp Operation	Ts=+70°C, 96hrs	Per table in below
2	Low Temp Operation	Ta=-20°C, 96hrs	Per table in below
3	High Temp Storage	Ta=+80°C, 96hrs	Per table in below
4	Low Temp Storage	Ta=-30°C, 96hrs	Per table in below
5	High Temp & High Humidity Storage	Ta=+60°C, 90% RH 96 hours	Per table in below (polarizer discoloration is excluded)
6	Thermal Shock (Non-operation)	-30°C 30 min~+80°C 30 min, Change time:5min, 10 Cycles	Per table in below
7	ESD (Operation)	C=150pF, R=330Ω · 5points/panel Air:±8KV, 5times; Contact:±4KV, 5 times;	Per table in below
8	Vibration (Non-operation)	Frequency range:10~55Hz, Stroke:1.5mm Sweep:10Hz~55Hz~10Hz 2 hours for each direction of X.Y.Z.	Per table in below
9	Shock (Non-operation)	60G 6ms, ±X,±Y,±Z 3times, for each direction	Per table in below
10	Package Drop Test	Height:80 cm, 1 corner, 3 edges, 6 surfaces	Per table in below

INSPECTION	CRITERION(after test)
Appearance	No Crack on the FPC, on the LCD Panel
Alignment of LCD Panel	No Bubbles in the LCD Panel No other Defects of Alignment in Active area
Electrical current	Within device specifications
Function / Display	No Broken Circuit, No Short Circuit or No Black line No Other Defects of Display



11. Precautions for Use of LCD Modules

11.1 Safety

The liquid crystal in the LCD is poisonous. Do not put it in your mouth. If the liquid crystal touches your skin or clothes, wash it off immediately using soap and water.

11.2 Handling

- A. The LCD and touch panel is made of plate glass. Do not subject the panel to mechanical shock or to excessive force on its surface.
- B. Do not handle the product by holding the flexible pattern portion in order to assure the reliability
- C. Transparency is an important factor for the touch panel. Please wear clear finger sacks, gloves and mask to protect the touch panel from finger print or stain and also hold the portion outside the view area when handling the touch panel.
- D. Provide a space so that the panel does not come into contact with other components.
- E. To protect the product from external force, put a covering lens (acrylic board or similar board) and keep an appropriate gap between them.
- F. Transparent electrodes may be disconnected if the panel is used under environmental conditions where dew condensation occurs.
- G. Property of semiconductor devices may be affected when they are exposed to light, possibly resulting in IC malfunctions.
- H. To prevent such IC malfunctions, your design and mounting layout shall be done in the way that the IC is not exposed to light in actual use.

11.3 Static Electricity

- A. Ground soldering iron tips, tools and testers when they are in operation.
- B. Ground your body when handling the products.
- C. Power on the LCD module before applying the voltage to the input terminals.
- D. Do not apply voltage which exceeds the absolute maximum rating.
- E. Store the products in an anti-electrostatic bag or container.

11.4 Storage

- A. Store the products in a dark place at $+25^{\circ}\text{C} \pm 10^{\circ}\text{C}$ with low humidity (40% RH to 60% RH). Don't expose to sunlight or fluorescent light.
- B. Storage in a clean environment, free from dust, active gas, and solvent.

11.5 Cleaning

- A. Do not wipe the touch panel with dry cloth, as it may cause scratch.
- B. Wipe off the stain on the product by using soft cloth moistened with ethanol. Do not allow ethanol to get in between the upper film and the bottom glass. It may cause peeling issue or defective operation. Do not use any organic solvent or detergent other than ethanol.

11.6 Cautions for installing and assembling

Bezel edge must be positioned in the area between the Active area and View area. The bezel may press the touch screen and cause activation if the edge touches the active area. A gap of approximately 0.5mm is needed between the bezel and the top electrode. It may cause unexpected activation if the gap is too narrow. There is a tolerance of 0.2 to 0.3mm for the outside dimensions of the touch panel and tail. A gap must be made to absorb the tolerance in the case and connector.

In order to make the display assembly stable and firm, Midas recommends to design some supporting at the display backside, especially for the display with tape-attached touch panel, such supporting is important and essential, or else, the display may drop-off from front after some period of time.

