

RoHS & Halogen Free & REACH Compliance.

SPECIFICATION FOR APPROVAL

Customer : _____

Customer P/N: _____

Drawing No : _____

Quantity : X Pcs. Date : 2024/06/13

Pulse P/N : BDCC00252012R47MCG

SPECIFICATION ACCEPTED BY:	
COMPONENT ENGINEER	
ELECTRICAL ENGINEER	
MECHANICAL ENGINEER	
APPROVED	
REJECTED	

Pingzhen
No.270, Nanfeng Rd., Pingzhen Dist.,
Taoyuan City 324019, Taiwan
TEL : +886-2-6621-6900
FAX : +886-3-419-2199

Dongguan
No. 78, Puxing Rd., Yuliangwei Administration
Area, Qingxi Town, Dongguan City,
Guangdong, China
TEL : +86-769-8773-0251~3
FAX : +86-769-8773-0232

Drawn by Chang.Yuwen	Checked by Tom.Chen	Approved by Jacky.Chung
--------------------------------	-------------------------------	-----------------------------------

BDCC00252012 Series Specification

1 Scope: This specification applies to Molding power inductors

2 Part Numbering:

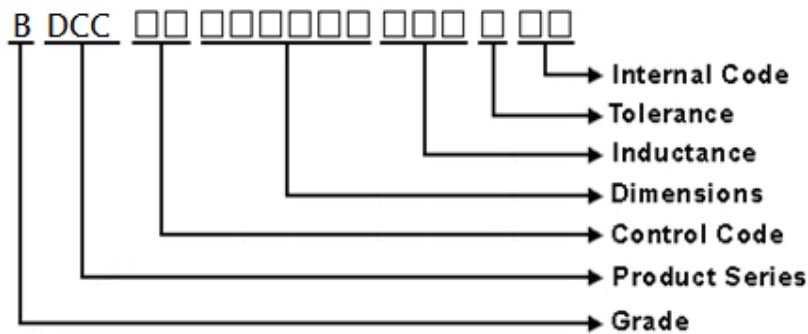

3 Rating:

Operating Temperature: - 40°C ~125°C(Including self-temperature rise)

4 Marking:



5 Standard Testing Condition

	Unless otherwise specified	In case of doubt
Temperature	Ordinary Temperature(15 to 35°C)	20 to 30°C
Humidity	Ordinary Humidity(25 to 85% RH)	50 to 80 %RH

BDCC00252012 Series Specification

6 Configuration and Dimensions:

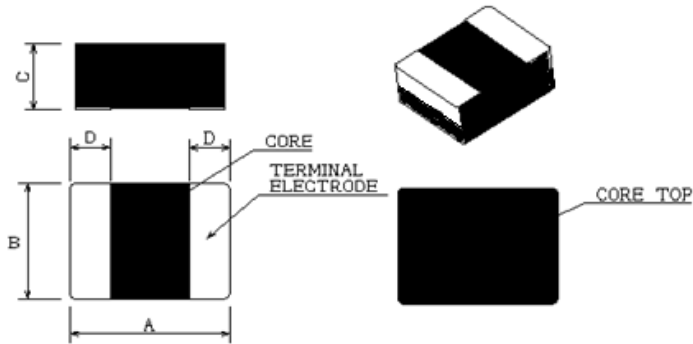

Dimensions in mm

TYPE	252012
A	2.5±0.2
B	2.0±0.2
C	1.2 Max.
D	0.6±0.3

Net Weight (grms)

Size Code	Net Weight (grms)
252012	≐0.0365

7 Electrical Characteristics:

Part No.	Inductance (μ H)	Tolerance (\pm %)	Test Freq.	I _{rms} (A) Max.(Typ)	I _{sat} (A) Max.(Typ)	RDC(m Ω) Max.(Typ)
BDCC00252012R47MCG	0.47	20	2MHz,1V	6.0(6.7)	6.7(7.4)	13.5(11)

NOTE:

1. Operating temperature range - 4 0°C ~ 1 2 5°C(Including self - temperature rise)
2. I_{sat} for Inductance drop 30% from its value without current.
3. I_{rms} for a 40°C temperature rise from 25°C ambient.
4. All test data is referenced to 25°C ambient
5. Absolute maximum voltage 20VDC
6. Rated current: I_{sat} or I_{rms}, whichever is smaller

BDCC00252012 Series Specification

8 BDCC00252012Series

8.1 Construction:

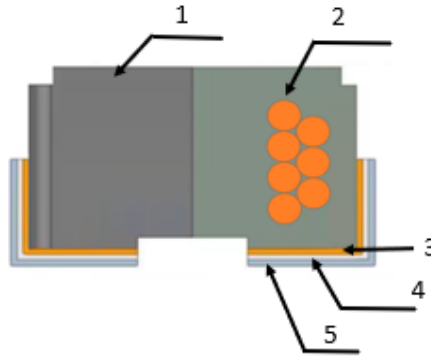

8.2 Material List:

ITEM	PART	DESCRIPTION
1	Core	Metal Powder
2	Wire	Copper wire
3	Terminal	Cu
4		Ni
5		Sn

BDCC00252012 Series Specification

9 Reliability Of Molding power inductors

1-1.Mechanical Performance

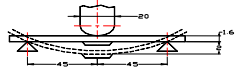
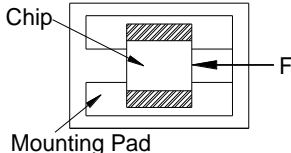
No	Item	Specification	Test Method
1-1-1	Flexure Strength	The forces applied on the right conditions must not damage the terminal electrode and the metal body	Test device shall be soldered on the substrate Substrate Dimension: 100x40x1.6mm Deflection: 2.0mm Keeping Time: 30sec 
1-1-2	Vibration	Appearance: No damage (for microscope of CASTOR MZ-45 20X) Inductance change shall be within $\pm 20\%$	Test device shall be soldered on the substrate Oscillation Frequency: 10 to 55 to 10Hz for 1min Amplitude: 1.5mm Time: 2hrs for each axis (X, Y & Z), total 6hrs
1-1-3	Resistance to Soldering Heat	Appearance: No damage More than 75% of the terminal electrode should be covered with solder. Inductance: within $\pm 20\%$ of initial value	Pre-heating: 150°C, 1min Solder Composition: Sn/Ag3.0/Cu0.5(Pb-Free) Solder Temperature: 260 \pm 5°C Immersion Time: 10 \pm 1sec
1-1-4	Solder ability	The electrodes shall be at least 95% covered with new solder coating	Pre-heating: 150°C, 1min Solder Composition: Sn/Ag3.0/Cu0.5(Pb-Free) Solder Temperature: 245 \pm 5°C Immersion Time: 4 \pm 1sec
1-1-5	Terminal Strength Test	No split termination  Chip Mounting Pad	Test device shall be soldered on the substrate, then apply a force in the direction of the arrow. Force : 5N Keeping Time: 10 \pm 1sec

1-2.Environmental Performance

No	Item	Specification	Test Method															
1-2-1	Temperature Cycle	Appearance: No damage Inductance: within $\pm 20\%$ of initial value	One cycle: <table border="1" style="width: 100%; border-collapse: collapse;"> <thead> <tr> <th>Step</th> <th>Temperature (°C)</th> <th>Time (min)</th> </tr> </thead> <tbody> <tr> <td>1</td> <td>-40\pm3</td> <td>30</td> </tr> <tr> <td>2</td> <td>25\pm2</td> <td>3</td> </tr> <tr> <td>3</td> <td>125\pm3</td> <td>30</td> </tr> <tr> <td>4</td> <td>25\pm2</td> <td>3</td> </tr> </tbody> </table> Total: 100cycles Measured after exposure in the room condition for 24hrs	Step	Temperature (°C)	Time (min)	1	-40 \pm 3	30	2	25 \pm 2	3	3	125 \pm 3	30	4	25 \pm 2	3
Step	Temperature (°C)	Time (min)																
1	-40 \pm 3	30																
2	25 \pm 2	3																
3	125 \pm 3	30																
4	25 \pm 2	3																
1-2-2	Humidity Resistance		Temperature: 60 \pm 2°C Relative Humidity: 90 ~ 95% / Time: 1000hrs Measured after exposure in the room condition for 24hrs															
1-2-3	High Temperature Resistance		Temperature: 125 \pm 3°C Relative Humidity: 0% / Time: 1000hrs Measured after exposure in the room condition for 24hrs															
1-2-4	Low Temperature Resistance		Temperature: -40 \pm 3°C Relative Humidity: 0% / Time: 1000hrs Measured after exposure in the room condition for 24hrs															

BDCC00252012 Series Specification

Reflow Profile

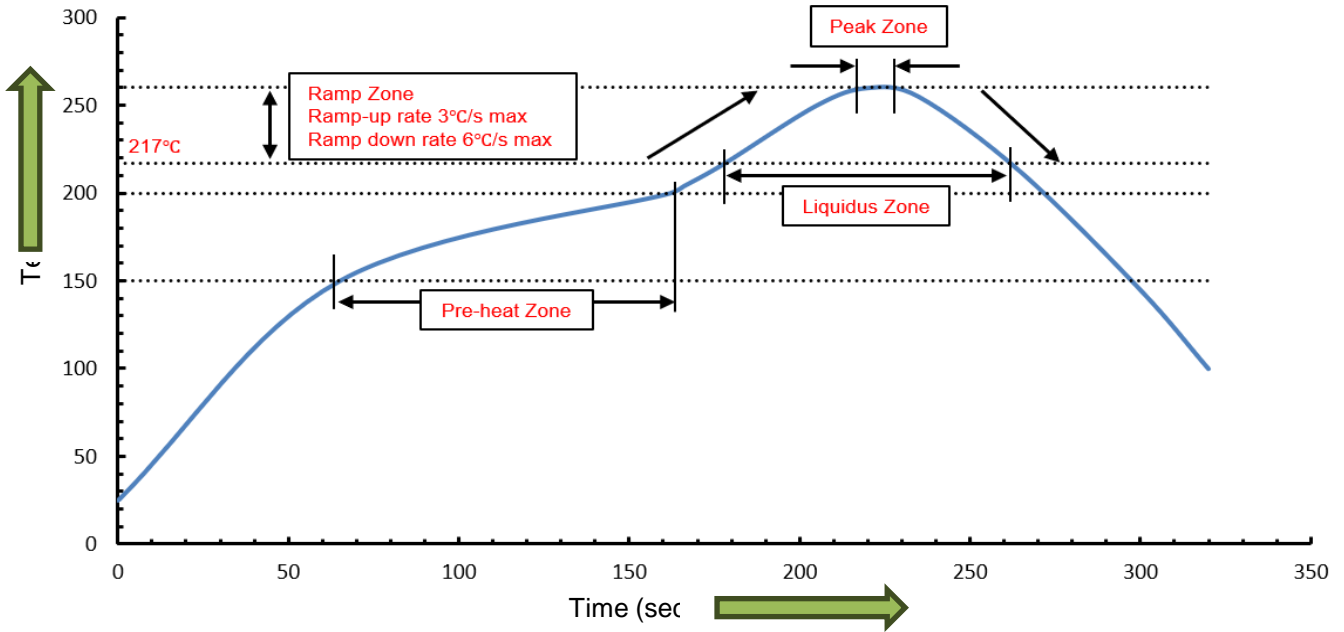

Refer to J-STD-020F

Profile Feature	Pre-heat Zone	Ramp-up Zone	Liquidus Zone	Peak Zone	Ramp-down Zone
Temperature	150~200°C	217°C~T _p	above 217°C	above 255°C	T _p ~217°C
Time	60~120sec	---	60~150sec	<30sec	---
Rate	---	< 3°C/sec	---	---	< 6°C/sec

Note:

1. T_p<260°C
2. Time [25°C to peak temperature] < 8 minutes
3. Reflow soldering must not be performed more than 3 times.
4. For superior solder joint connectivity results, soldering under standard nitrogen atmosphere is recommended.

BDCC00252012 Series Specification

10 Packaging:

10.1 Packaging -Cover Tape

The force for tearing off cover tape is 10 to 100 grams in the arrow direction.

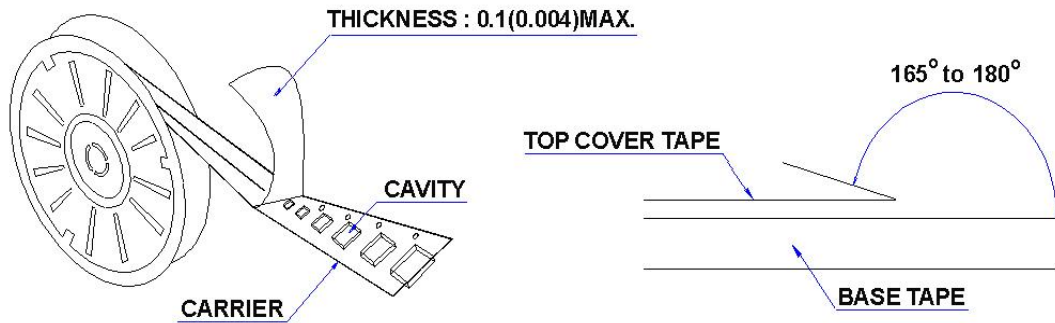

10.2 Packaging Quantity

TYPE	PCS/REEL
252012	3000

10.3 Reel Dimensions

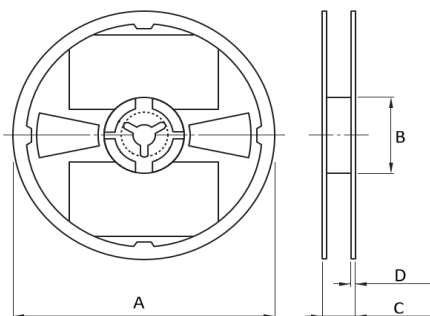

Dimensions in mm

TYPE	A	B	C	D
252012	178	60	12	1.5

BDCC00252012 Series Specification

10 Packaging:

10.4 Tape Dimensions in mm

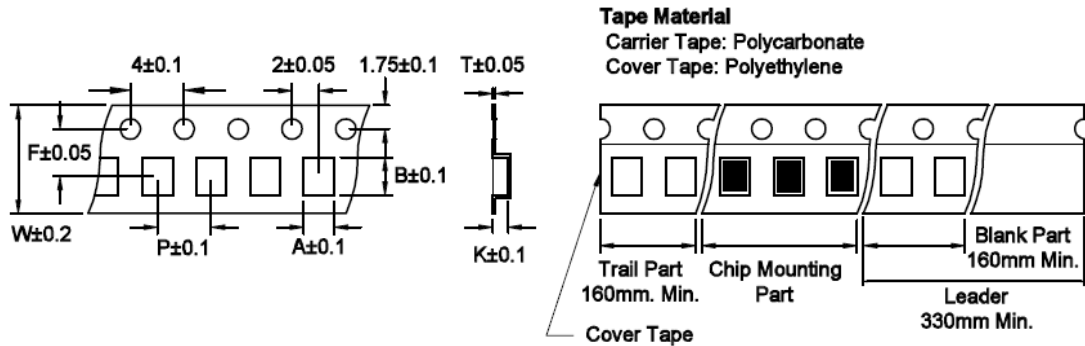

TYPE	A	B	T	W	P	F	K
252012	2.30	2.80	0.22	8	4	3.5	1.35

11 Recommended Land Pattern:

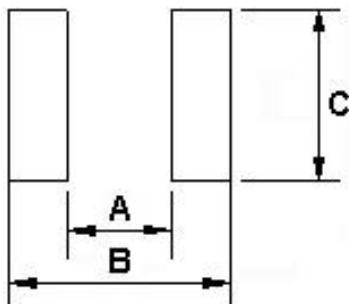

Dimensions in mm

TYPE	A	B	C
252012	1.3	2.8	2.2

12 Note:

- The storage period is within 12 months. Products should be stored in the warehouse on the following condition: (Temperature: 5~40°C; Humidity: 20%~75%RH).
Solderability should be checked if the period is exceeded.
- Please make sure that your product has been evaluated and confirmed against your specifications when our product is mounted to your product.
- Do not knock nor drop.
- All the items and parameters in this product specification have been prescribed on the premise that our product is used for the purpose, under the condition and in the environment agreed upon between you and us. You are requested not to use our product deviating from such agreement.
- Please keep the distance between transformer/coil and other components (refer to the standard IEC 950)

BDCC00252012 Series Specification

13 Graph:

