



Flexible LED Neon Strips – RGB Addressable

ILPN-K517-RGB1-2M0-SK1xx10-I1

Unlike traditional Neon strips, this ILS product has no need for transformers or high-cost glass tubing and gasses. Featuring an RGB addressable LED strip with translucent silicone rubber diffuser enabling the neon style. IP67 rating allows the Neon Flex to withstand normal environmental conditions, meaning they are suitable for use inside or out. Supplied as a 2-meter reel, with power connections on one end. The Neon Flex can be cut at intervals, allowing adaptability to various applications. End caps are also available to enable the IP rating to be sustained regardless of adjustments.



CONTENTS

Applications	page 2	Flexible LED Neon End Caps	page 4
Technical Features	page 2	Wiring Connection	page 5
Product Options	page 3	Important Information and Precautions	page 5
Technical Drawings	page 3	Safety Information	page 6
Flexible LED Neon Mounting	page 4		

APPLICATIONS

- » Task Lighting
- » Back Lighting
- » Desk Lighting
- » Garage Lighting
- » Accent Lighting
- » Under Cabinet Lighting
- » Bar Lighting
- » Refrigeration
- » Industrial
- » Photography

TECHNICAL FEATURES

LED Family	5050 RGB
Mounting	Mounting is simple using clip in brackets
Dimensions	Reel Length - 2000mm
Wiring	Strip is pre-wired with connector fitted
Max single power run	5m
Working Voltage	5V, 12V and 24V DC Constant Voltage
Operating temperature	-30°C - 70°C
Storage temperature	-40°C - 85°C

PRODUCT OPTIONS

ILS Part Number	Colour	Operating Voltage
ILPN-K517-RGB1-2M0-SK10510-I1	RGB	5V DC
ILPN-K517-RGB1-2M0-SK11210-I1	RGB	12V DC
ILPN-K517-RGB1-2M0-SK12410-I1	RGB	24V DC

TECHNICAL DRAWINGS (MM)

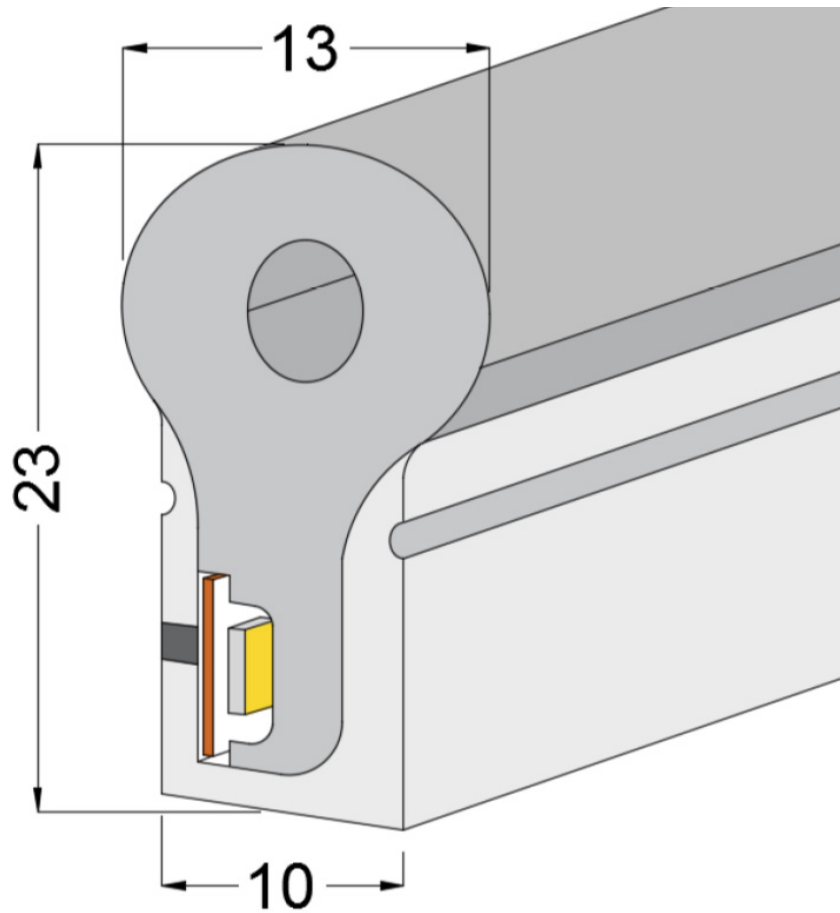

FLEXIBLE LED NEON MOUNTING: ILPA-NEON-BRACKET

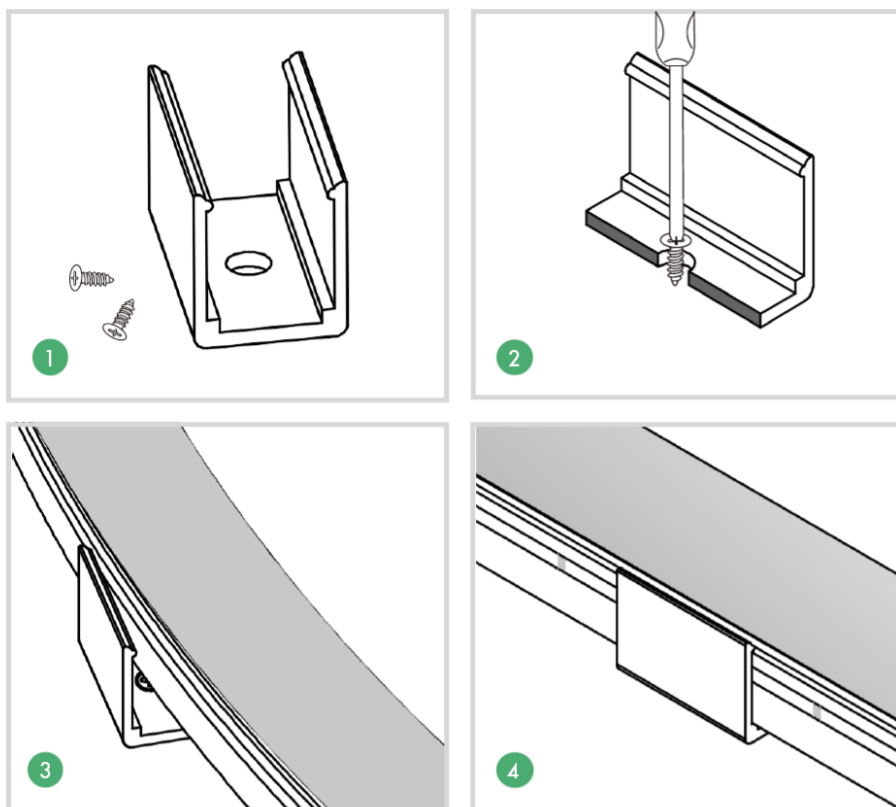

FLEXIBLE LED NEON END CAPS

If you decide to cut your Flexible LED Neon strips, then we have a number of options for end caps;

ILPA-NEON-CAP-RIGHT

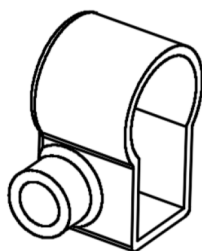

ILPA-NEON-CAP-LEFT



ILPA-NEON-CAP-END



ILPA-NEON-CAP-BLANK



WIRING CONNECTION

Each Neon Flex has the 3PIN Connector at the end side.

The male connector is signal input.

The female connector is signal output.

Cable connection: Red wire is for power + 5V, 12V & 24V
 Yellow wire is for power - (GND)
 Green wire is for data signal

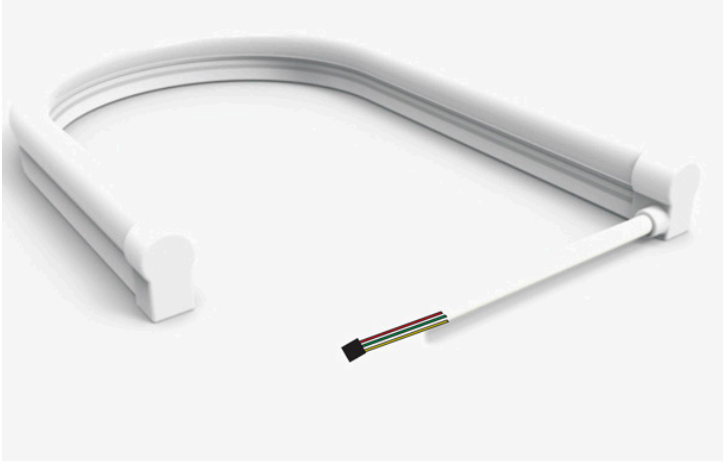

IMPORTANT INFORMATION AND PRECAUTIONS



When powered up, the product, is very bright. Thus it is advised that you do not look directly at it. Turn the Neon Strips away from you and do not shine into the eyes of others.



When powered up, the product, can reach high temperatures thus there is risk of injury if they are touched.



Products will overheat in operation if not attached to a suitable heatsink. Overheating can cause failure or irreparable damage.



DO NOT HOT PLUG ON LED SIDE OF POWER SUPPLY.



Do not operate products with a power supply with unlimited current. Connection to constant voltage power supplies that are not current limited may cause the products to consume current above the specified maximum and cause failure or irreparable damage.



DO NOT TOUCH or PUSH on the LED as this can cause irreparable damage.

SAFETY INFORMATION



The LED module itself and all its components must not be mechanically stressed.



Assembly must not damage or destroy conducting paths on the circuit board.



The mounting of the module is carried out by attaching it at the mounting holes. Metal mounting screws must be insulated with synthetic washers to prevent circuit board damage and possible short circuiting.



To avoid mechanical damage to the connecting cables, the boards should be attached securely to the intended substrate. Heavy vibration should be avoided.



Observe correct polarity! Depending on the product, incorrect polarity will lead to emission of red or no light. The module can be destroyed!



Pay attention to standard ESD precautions when installing the products.



Products, as manufactured, have no conformal coating and therefore offer no inherent protection against corrosion. Damage by corrosion will not be accepted as a materials defect claim. It is the user's responsibility to provide suitable protection against corrosive agents such as moisture and condensation and other harmful elements.



For outdoor usage, a housing is definitely required to protect the board against environmental influences. The design of the housing must correspond to the IP standards in the application. It is also the responsibility of the user to ensure any housings or modifications keep the T_c junction temperature to within stated ranges.



To also ease the luminaire/installation approval, electronic control gear for LED or LED modules should carry the CE mark and be ENEC certified. In Europe the declarations of conformity must include the following standards: CE: EC 61374-2-13, EN 55015, IEC 61547 and IEC 61000-3-2 - ENEC: 61374-2-13 and IEC/EN 62384.



The evaluation of eye safety occurs according to the standard IEC 62471:2006 ("photobiological safety of lamps and lamp systems"). Within the risk grouping system of this CIE standard, the LED specified in this datasheet falls into the class "moderate risk" (exposure time 0.25s). Under real circumstances (for exposure time, eye pupils, observation distance), it is assumed that no endangerment to the eye exists from these devices. As a matter of principle, however, it should be mentioned that intense light sources have a high secondary exposure potential due to their blinding effect. As is also true when viewing other bright light sources (e.g. headlights), temporary reduction in visual acuity and afterimages can occur, leading to irritation, annoyance, visual impairment and even accidents, depending on the situation.

FURTHER INFORMATION

The values contained in this datasheet can change due to technical innovation. Any such changes will be made without separate notification.

If you require further assistance or have a specific or custom enquiry, please contact the ILS team via email or phone. Alternatively please visit our website for more product information and to see our full ranges.



Unit 2, Berkshire Business Centre,
Berkshire Drive, Thatcham,
Berkshire, RG19 4EW

+44 (0)1635 294606

info@i-led.co.uk

<https://i-led.co.uk>

ABOUT ILS

ILS offers a high level of technical skill, professionalism and commercial understanding to companies requiring market-leading optoelectronics solutions. Offering conceptual advice, electronics design and manufacturing capability, we use high quality production resources both in-house and in Asia, providing project support from prototyping to mass production. We also understand the need to provide cost-effective solutions and we do so using high quality components to ensure that the end product's reliability and quality is uncompromised. Apart from LEDs in the visible spectrum, we have a wide range of [Infrared](#), [UV LEDs](#), [UV tubes](#), and lasers.

ILS is a division of [Intelligent Group Solutions Ltd \(IGS\)](#) a well-established respected industry leading Optoelectronics solutions provider. Much of IGS' business comes from providing semi-custom or custom products both in component and sub-assembly form, and from providing design support and prototyping within the European market place. We can deliver production displays to wherever in the world that the customer's manufacturing or assembly is being undertaken.

INTELLIGENT GROUP SOLUTIONS DIVISIONS

