

# Impregnated Metallized Paper EMI Suppression Capacitors SMP255, Class X2, 310 VAC SMD (Automotive Grade)

## Overview

Multilayer, metallized paper, encapsulated and impregnated in self-extinguishing material that meets the requirements of UL 94 V-0.

## Applications

The capacitors are intended for use as interference suppressors in X2 (across-the-line) applications.

## Benefits

- High dV/dt capability
- Impregnated paper that ensures excellent stability and reliability properties, particularly in applications with continuous operation
- Approvals: ENEC, cULus
- Rated voltage: 310 VAC 50/60 Hz, maximum recommended DC voltage 630 VDC
- Capacitance range: 10 – 150 nF
- Size code: 5045 (12.7 mm), 6560 (16.5 mm), 7067 (17.8 mm)
- Capacitance tolerance:  $\pm 20\%$
- Automotive (AEC-Q200) grade

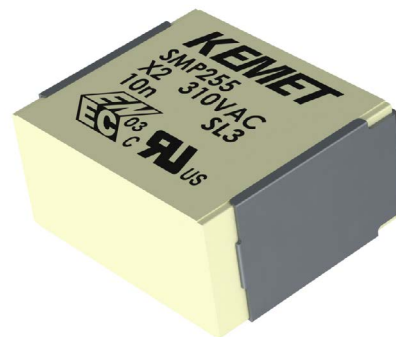

## Customer Part Number System

SMP255	F	A	5100	M	B31	TR24
Series	Rated Voltage (VAC)	Chip Length (mm)	Capacitance Code (pF)	Capacitance Tolerance	Box	Packaging
X2, Metallized Paper	F = 310	A = 12.7 B = 16.5 C = 17.8	The last three digits represent significant figures. The first digit specifies the total number of digits.	M = $\pm 20\%$	Box B31 = 5045 and 5026 chip sizes C31 = 6560 and 6528 chip sizes D32 = 7067 and 7040 chip sizes	See Ordering Options Table

## KEMET Internal Part Number System

P	106	YR	103	M	310	V
Capacitor Class	Series	Chip Length (mm)	Capacitance Code (pF)	Capacitance Tolerance	Rated Voltage (VAC)	Packaging
P = Paper	X2, Metallized paper	YR = 12.7 ZS = 16.5 FK = 17.8	First two digits represent significant figures. Third digit specifies number of zeros.	M = $\pm 20\%$	310 = 310	See Ordering Options Table

## Benefits cont.

- Climatic category: 40/125/56/B, IEC 60068-1
- Tape & Reel packaging in accordance with IEC 60286-3
- RoHS compliance and lead-free terminations
- Operating temperature range of -40°C to +125°C
- 100% screening factory test at 2,150 VDC
- Highest possible safety regarding active and passive flammability
- Excellent self-healing properties ensure long life, even when subjected to frequent overvoltages
- Good resistance to ionization due to impregnated dielectric

## Ordering Options Table

Chip Size (EIA)	Packaging Type	KEMET Packaging Code	Legacy Packaging Code
5045, 6560	Tape & Reel (Horizontal Taping Orientation)	V	TR24
7067	Tape & Reel (Horizontal Taping Orientation)	V	TR32
5026	Tape & Reel (Vertical Taping Orientation)	Y	TV24
6528	Tape & Reel (Vertical Taping Orientation)	Y	TV44
7040	Tape & Reel (Vertical Taping Orientation)	Y	TV32

## Dimensions – Millimeters

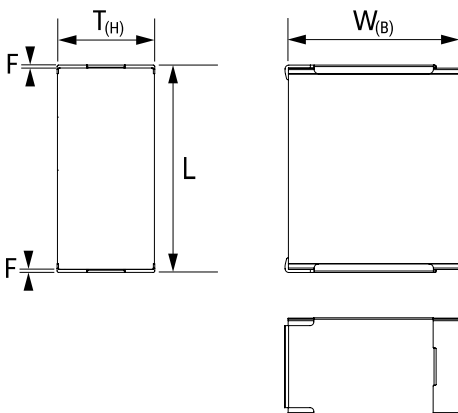

Chip Size	W		T		L		F	
	Nominal	Tolerance	Nominal	Tolerance	Nominal	Tolerance	Nominal	Tolerance
5045	11.5	-0/+0.6	6.5	-0/+0.4	12.7	-0/+0.4	0.5	Nominal
6560	15.0	-0/+0.6	7.0	-0/+0.4	16.5	-0/+0.4	0.5	Nominal
7067	17.0	-0/+0.6	10.2	-0/+0.4	17.8	-0/+0.4	0.5	Nominal
5026	6.5	-0/+0.6	11.5	-0/+0.4	12.7	-0/+0.4	0.5	Nominal
6528	7.0	-0/+0.6	15.0	-0/+0.4	16.5	-0/+0.4	0.5	Nominal
7040	10.2	-0/+0.6	17.0	-0/+0.4	17.8	-0/+0.4	0.5	Nominal

## Performance Characteristics

Rated Voltage	310 VAC 50/60 Hz
Capacitance Range	1.0 – 150 nF
Capacitance Tolerance	±20% (at room temperature)
Temperature Range	-40°C to +125°C
Climatic Category	40/125/56/B
Approvals	ENEC, cULus
Storage Conditions	Storage time: ≤ 24 months from the date marked on the label package
	Average relative humidity per year ≤ 70%
	RH ≤ 85% for 30 days randomly distributed throughout the year
	Dew is absent
	Temperature: -40 to 80°C (see "Maximum Humidity in Storage Conditions" graph below)
Dissipation Factor (tanδ) at 1 kHz	Maximum Values at +23°C
	≤ 1.3%
Test Voltage Between Terminals	The 100% screening factory test is carried out at 2,150 VDC. The voltage level is selected to meet the requirements in applicable equipment standards. All electrical characteristics are checked after the test. This test may not be repeated due to potential capacitor damage. KEMET is not liable for any failures that result from repeating the test.
Insulation Resistance	Between Terminals
	≥ 12,000 MΩ

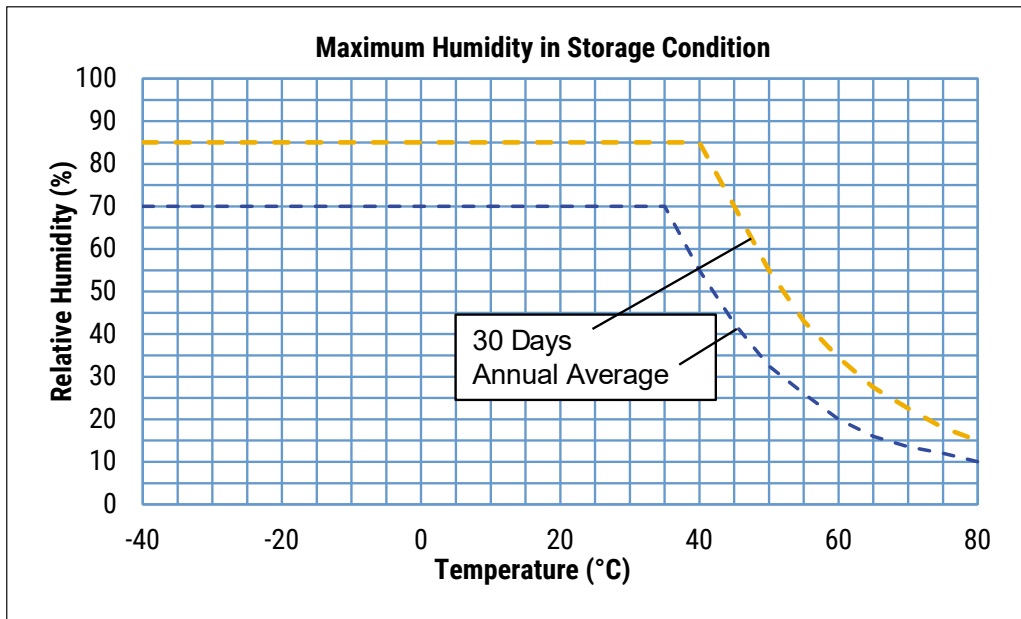

## Qualification

Automotive grade products meet or exceed the requirements outlined by the Automotive Electronics Council. Details regarding test methods and conditions are referenced in document AEC-Q200, Stress Test Qualification for Passive Components. For additional information regarding the Automotive Electronics Council and AEC-Q200, please visit their website at [www.aecouncil.com](http://www.aecouncil.com).

---

## Cleaning/Storage and Moisture Recommendations

### Cleaning Suggestions

To clean the PCB assembly KEMET recommends to use a suitable solvent like Isopropyl alcohol, deionized water or neutral pH detergents. Aggressive solvents shall not be used. For any different cleaning solvent used please contact KEMET Technical Services to analyze the potential impact on KEMET products.



### Storage and Moisture Recommendations

KEMET SMD film capacitors are supplied in a moisture barrier bag (MBB) Class 1. We can guarantee a 24 month shelf life (temperature  $\leq 40^{\circ}\text{C}$ /relative humidity  $\leq 90\%$ ). After the MBB has been opened, components may stay in areas with controlled temperature and humidity (temperature  $\leq 30^{\circ}\text{C}$ /relative humidity  $\leq 60\%$ ) for 168 hours (MSL 3). For longer periods of time and/or higher temperature and/or higher relative humidity values, it is absolutely necessary to protect the components against humidity. If the reel inside the MBB is partially used, KEMET recommends to re-use the same MBB or to avoid areas without controlled temperature and humidity (see above). If the above conditions are not respected, components require baking (minimum time: 48 hours at  $55 \pm 5^{\circ}\text{C}$ ,  $\leq 5\%$  RH) before the reflow.

## Environmental Test Data

Test	Publication	Procedure
Impulse Voltage and Endurance	IEC 60384-14	1.25 x V <sub>R</sub> VAC 50 Hz, once every hour increase to 1,000 VAC for 0.1 second, 1,000 hours at upper rated temperature.
Vibration	IEC 60068-2-6 Test Fc	3 directions at 2 hours each. 10 – 500 Hz at 0.75 mm or 98 m/s <sup>2</sup>
Bump	IEC 60068-2-27 Test Eb	4,000 bumps at 390 m/s <sup>2</sup>
Rapid Change of Temperature	IEC 60068-2-14 Test Na	Upper and lower rated temperature 5 cycles
Active Flammability	IEC 60384-14	V <sub>R</sub> + 20 surge pulses at 2.5 kV (pulse every 5 seconds)
Passive Flammability	IEC 60384-14 IEC 60695-11-5	Needle-flame test
Humidity	IEC 60068-2-3 Test Ca	+40°C and 90 – 95% R.H.
Damp Heat Steady State	IEC 60068-2-78 Test Cab	+40 ±2°C and 93 ±3% R.H., 56 days
Operational Life Test	AEC-Q200: MIL-STD-202 Method 108	100% of rated voltage above 85°C. 1,000h/125°C
Humidity Bias Test	AEC-Q200: MIL-STD-202 Method 103	Rated voltage. 1,000h. 40°C/93%RH
Temperature Cycling Test	AEC-Q200: JESD22-A104	Unpowered. 1,000 cycles. 125°C/-40°C

## Approvals

Certification Body	Mark	Specification	File Number
IMQ S.p.A.		EN/IEC 60384-14	CA08.00240
UL		UL 60384 and CAN/CSA E60384-14	E97797

## Environmental Compliance

All KEMET EMI capacitors are RoHS compliant.



**Table 1 – Ratings & Part Number Reference**

Chip Capacitance (nF)	Maximum Dimensions in mm			dV/dt (V/μs)	KEMET Part Number	Customer Part Number
	L -0/+0.4	W -0/+0.6	T -0/+0.4			
10	12.7	11.5	6.5	1,200	P106YR103M310(1)	SMP255FA5100MB31(1)
12	12.7	11.5	6.5	1,200	P106YR123M310(1)	SMP255FA5120MB31(1)
15	12.7	11.5	6.5	1,200	P106YR153M310(1)	SMP255FA5150MB31(1)
18	12.7	11.5	6.5	1,200	P106YR183M310(1)	SMP255FA5180MB31(1)
22	12.7	11.5	6.5	1,200	P106YR223M310(1)	SMP255FA5220MB31(1)
27	12.7	11.5	6.5	1,200	P106YR273M310(1)	SMP255FA5270MB31(1)
33	16.5	15.0	7.0	1,200	P106ZS333M310(1)	SMP255FB5330MC31(1)
39	16.5	15.0	7.0	1,200	P106ZS393M310(1)	SMP255FB5390MC31(1)
47	16.5	15.0	7.0	1,200	P106ZS473M310(1)	SMP255FB5470MC31(1)
56	16.5	15.0	7.0	1,200	P106ZS563M310(1)	SMP255FB5560MC31(1)
68	16.5	15.0	7.0	1,200	P106ZS683M310(1)	SMP255FB5680MC31(1)
82	17.8	17.0	10.2	1,200	P106FK823M310(1)	SMP255FC5820MD32(1)
100	17.8	17.0	10.2	1,200	P106FK104M310(1)	SMP255FC6100MD32(1)
120	17.8	17.0	10.2	600	P106FK124M310(1)	SMP255FC6120MD32(1)
150	17.8	17.0	10.2	600	P106FK154M310(1)	SMP255FC6150MD32(1)
Capacitance Value (nF)	L (mm)	W (mm)	T (mm)	dV/dt (V/μs)	Customer Part Number	KEMET Part Number

(1) Insert packaging code. See Ordering Options Table for available options.

## Soldering Process

Reflow soldering temperature is measured on the top body surface of the component. Use the recommended soldering profiles for convection reflow ovens and IR reflow ovens. If a vapor phase reflow oven is used, consult KEMET. Exceeding the manufacturer’s process recommendations may harm the component. KEMET is not liable for any defect caused by exceeding recommendations. According to international standards, the maximum temperature capability must be measured on the top surface of a component. The international standards do not define how the thermocouple should be fastened on the component. Our recommendation for attaching the thermocouple to the top surface of the component is to glue it with high temperature resistant glue or with thermo tape specified for reflow profiling. Compliant to lead-free reflow soldering process.

Profile Feature	Termination Finish
	100% Matte Sn
<b>Preheat/Soak</b>	
Temperature Minimum ( $T_{Smin}$ )	150°C
Temperature Maximum ( $T_{Smax}$ )	200°C
Time ( $t_s$ ) from $T_{Smin}$ to $T_{Smax}$	60 - 120 seconds
Ramp-Up Rate ( $T_L$ to $T_p$ )	3°C/second maximum
Liquidous Temperature ( $T_L$ )	217°C
Time Above Liquidous ( $t_L$ )	60 - 150 seconds
Peak Temperature ( $T_p$ )	245°C
Time Within 5°C of Maximum Peak Temperature ( $t_p$ )	30 seconds maximum
Ramp-Down Rate ( $T_p$ to $T_L$ )	6°C/second maximum
Time 25° to Peak Temperature	8 minutes maximum

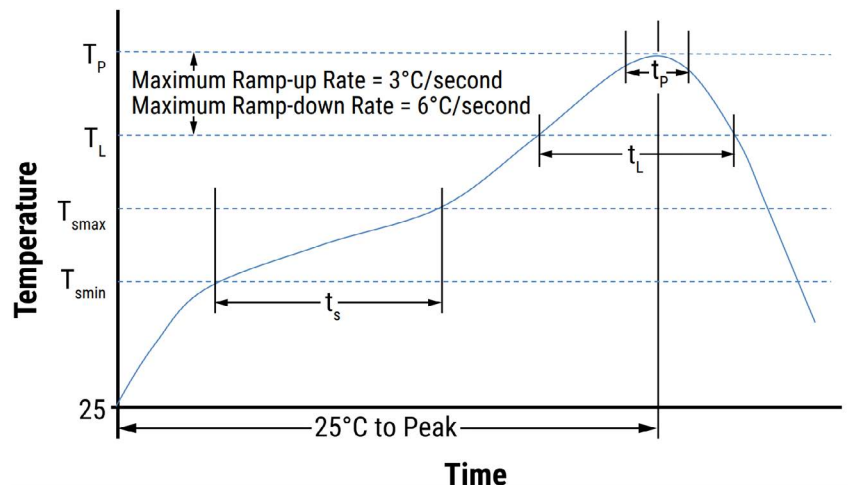

Note: All temperatures refer to the center of the package, measured on the capacitor body surface that is facing up during assembly reflow.

## Temperature Sensor Position in Reflow Profiling

For vertical capacitors profiling

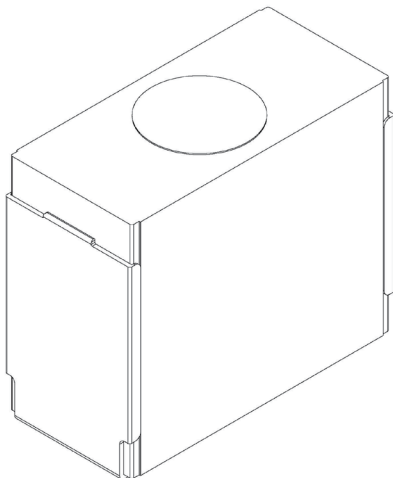

For horizontal capacitors profiling

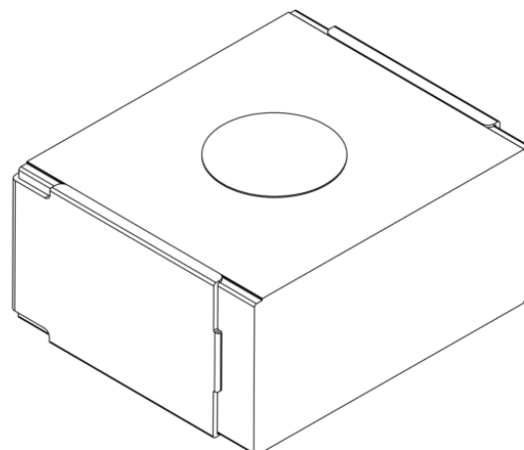

## Soldering Land Dimensions

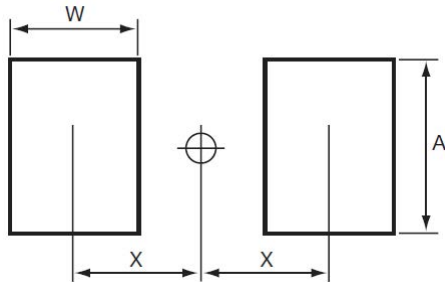

L	Case Size		W		Ah		Av		X	
	mm	Horizontal	Vertical	mils	mm	mils	mm	mils	mm	mils
12.7	5045	5026	100	2.5	455	11.6	260	6.6	276	7.0
16.5	6560	6528	120	3.0	590	15.0	280	7.1	355	9.0
17.8	7067	7040	140	3.5	670	17.0	405	10.3	374	9.5

Ah = horizontal mounting

Av = vertical mounting

## Mounting

### Resistance to Vibration and Mechanical Shock

AEC-Q200 Rev. E Mechanical Stress Tests:

<b>Mechanical Shock</b>	<b>MIL-STD-202 Method 213</b>	Figure 1 of Method 213 • SMD: Condition C • Tested per the Supplier's recommended mounting method
<b>Vibration</b>	<b>MIL-STD-202 Method 204</b>	• 5 g for 20 minutes, 12 cycles each of 3 orientations • Tested per the Supplier's recommended mounting method • Verification of transfer load: during setup, verify that with the selected PCB design (size, thickness and secure points), or an alternative mount, that the transferred load onto the component corresponds to the requested load. This verification can be achieved using a laser vibrometer or other adequate measuring device. • Test from 10 Hz – 2,000 Hz.



## Construction

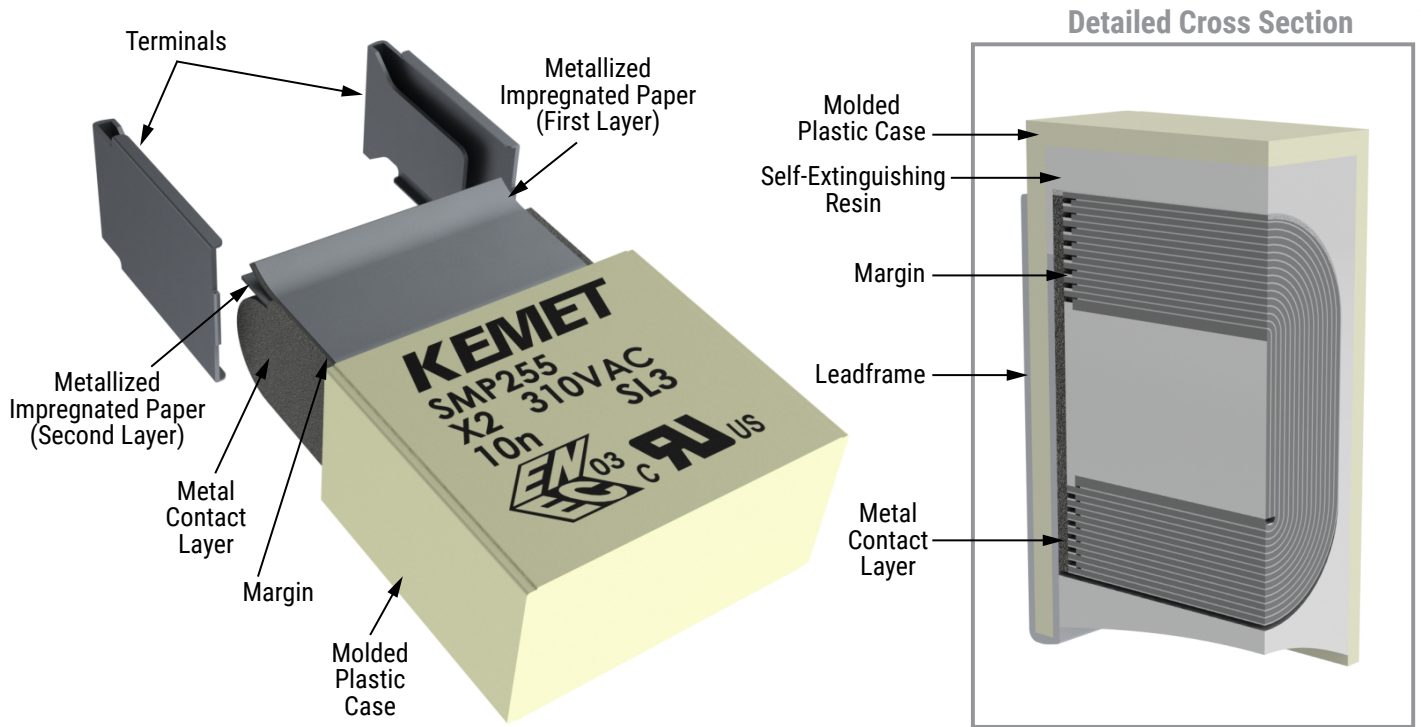

## Marking

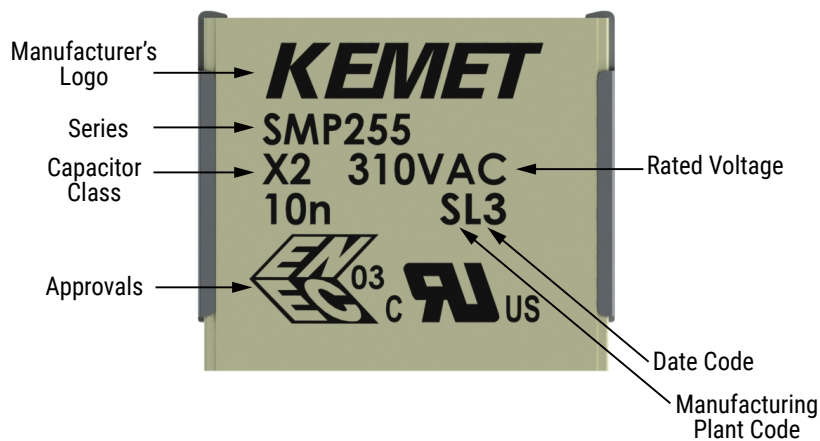

Manufacturing Plant & Date Code (IEC 60062)			
Year	Digit 2	Month	Digit 3
2020	M	January	1
2021	N	February	2
2022	P	March	3
2023	R	April	4
2024	S	May	5
2025	T	June	6
2026	U	July	7
2027	V	August	8
2028	W	September	9
2029	X	October	0
2030	A	November	N
2031	B	December	D
2032	C		
2033	D		
2034	E		
2035	F		
2036	H		
2037	J		
2038	K		
2039	L		
2040	M		

## Packaging Quantities

Chip Size EIA	Taping Orientation	Thickness (mm)	Height (mm)	Length (mm)	Packing Quantity
5045	Horizontal	6.5	11.5	12.7	600
5026	Vertical	11.5	6.5	12.7	400
6560	Horizontal	7.0	15.0	16.5	500
6528	Vertical	15.0	7.0	16.5	200
7067	Horizontal	10.2	17.0	17.8	270
7040	Vertical	17.0	10.2	17.8	200

## Carrier Taping & Packaging (IEC 60286-3)

### Horizontal Taping Orientation

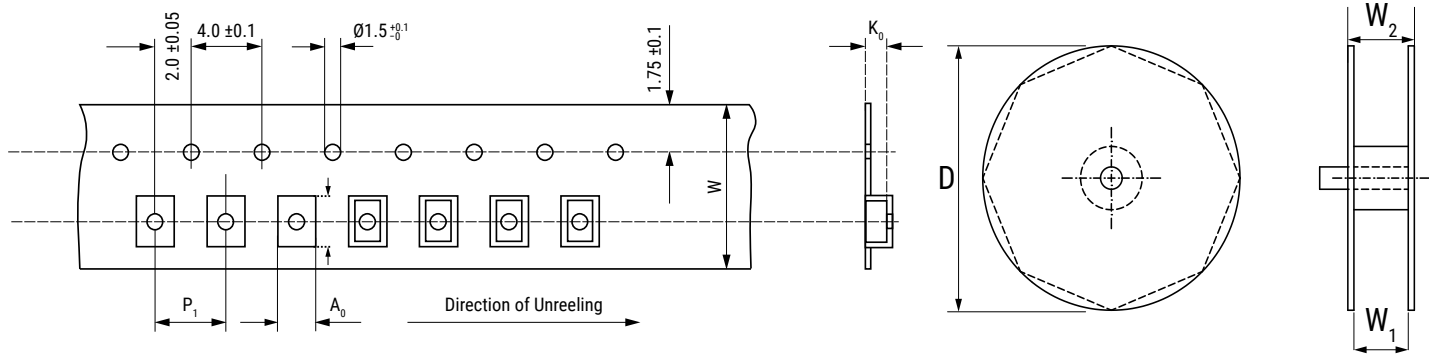

EIA Size Code Horizontal Mounting	Dimensions in mm			Taping Specification							
	B	H	L	W	P <sub>1</sub>	A <sub>0</sub>	B <sub>0</sub>	K <sub>0</sub>	D	W <sub>1</sub>	W <sub>2</sub>
	Nominal	Nominal	Nominal	-0/+0.3	+/-0.1	Nominal	Nominal	Nominal	±2.0	-0/+2	Maximum
5045	11.5	6.5	12.7	24.0	16.0	11.9	13.1	6.8	330	24.4	30.0
6560	15.0	7.0	16.5	24.0	20.0	15.4	16.8	7.3	330	24.4	30.0
7067**	17.0	10.2	17.8	32.0	24.0	17.9	18.5	10.9	330	32.4	38.0

\*\*Double sprocket holes.

### Vertical Taping Orientation

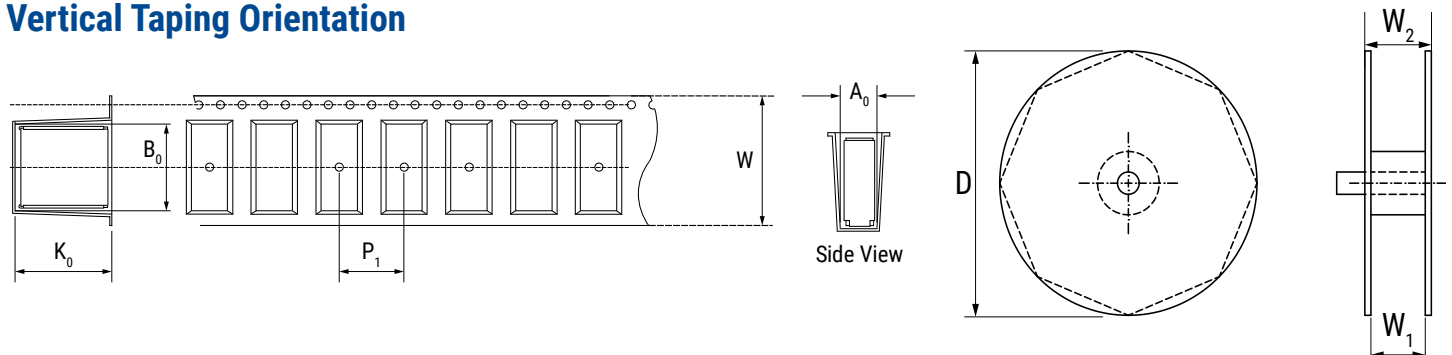

EIA Size Code Vertical Mounting	Dimensions in mm			Taping Specification							
	B*	H*	L	W	P <sub>1</sub>	A <sub>0</sub>	B <sub>0</sub>	K <sub>0</sub>	D	W <sub>1</sub>	W <sub>2</sub>
	Nominal	Nominal	Nominal	-0/+0.3	+/-0.1	Nominal	Nominal	Nominal	±2.0	-0/+2	Maximum
5026	6.5	11.5	12.7	24.0	16.0	6.9	13.1	11.8	330	24.4	30.0
6528**	7.0	15.0	16.5	44.0	20.0	7.5	17.0	15.3	330	44.4	50.0
7040**	10.2	17.0	17.8	32.0	20.0	10.9	18.5	19.9	330	32.4	38.0

\*Dimensions B and H in vertical mounting correspond to H and B in the standard mounting and in the article tables.

\*\*Double sprocket holes.

## KEMET Electronics Corporation Sales Offices

For a complete list of our global sales offices, please visit [www.kemet.com/sales](http://www.kemet.com/sales).

---

### Disclaimer

YAGEO Corporation and its affiliates do not recommend the use of commercial or automotive grade products for high reliability applications or manned space flight.

All product specifications, statements, information and data (collectively, the "Information") in this datasheet are subject to change. The customer is responsible for checking and verifying the extent to which the Information contained in this publication is applicable to an order at the time the order is placed. All Information given herein is believed to be accurate and reliable, but it is presented without guarantee, warranty, or responsibility of any kind, expressed or implied.

Statements of suitability for certain applications are based on KEMET Electronics Corporation's ("KEMET") knowledge of typical operating conditions for such applications, but are not intended to constitute – and KEMET specifically disclaims – any warranty concerning suitability for a specific customer application or use. The Information is intended for use only by customers who have the requisite experience and capability to determine the correct products for their application. Any technical advice inferred from this Information or otherwise provided by KEMET with reference to the use of KEMET's products is given gratis, and KEMET assumes no obligation or liability for the advice given or results obtained.

Although KEMET designs and manufactures its products to the most stringent quality and safety standards, given the current state of the art, isolated component failures may still occur. Accordingly, customer applications which require a high degree of reliability or safety should employ suitable designs or other safeguards (such as installation of protective circuitry or redundancies) in order to ensure that the failure of an electrical component does not result in a risk of personal injury or property damage.

Although all product-related warnings, cautions and notes must be observed, the customer should not assume that all safety measures are indicated or that other measures may not be required.

Additional information about production site flexibility can be found [here](#)

*KEMET is a registered trademark of KEMET Electronics Corporation.*