USB-8452

Specifications

2024-07-02



Contents

USB-8452 Specifications 3

USB-8452 Specifications

This section lists specifications for the USB-8452.

The following specifications are typical at 25 °C unless otherwise noted.



Note Specifications are subject to change without notice.

Digital I/O (DIO)

Number of lines	
DIO <0..7>	8
Direction control	Input or output, software selectable
Output driver type	Push-pull (active drive) or open-drain, software selectable
Absolute voltage range	-0.5 V to +5.5 V with respect to GND
Power-on state	Tri-state with weak (40 kΩ) pull down to GND

I/O specifications under different logic levels

Output Specifications			
Logic Family	Voltage Low Level (V_{OL}) (Full Temperature)	Voltage High Level (V_{OH}) (Full Temperature)	Output Drive Strength (I_{O_MAX})
	Max ($I_{OL} = 100 \mu A$)	Min ($I_{OH} = 100 \mu A$)	Max
1.2 V	0.2 V	1.0 V	± 3 mA
1.5 V	0.2 V	1.3 V	± 6 mA
1.8 V	0.2 V	1.6 V	± 8 mA
2.5 V	0.2 V	2.3 V	± 9 mA
3.3 V	0.2 V	3.1 V	± 12 mA
Output Impedance	70 Ω (typical)		

Input Specifications		
Logic Family	Input Voltage Low (V_{IL}) Max	Input Voltage High (V_{IH}) Min
1.2 V	0.42 V	0.78 V
1.5 V	0.525 V	0.975 V
1.8 V	0.63 V	1.17 V
2.5 V	0.7 V	1.6 V
3.3 V	0.8 V	2 V
Input Impedance	High impedance	
Input Protection	-0.5 V to +5.5 V, ± 50 mA maximum	

SPI Interface

Signal

SPI CS <0..7>	Output
SPI MOSI (SDO)	Output
SPI MISO (SDI)	Input
SPI CLK (SCLK)	Output (50 MHz max)
SPI system clock	100 MHz (10 ns period)
Supported clock rates	25 kHz, 32 kHz, 40 kHz, 50 kHz, 80 kHz, 100 kHz, 125 kHz, 160 kHz, 200 kHz, 250 kHz, 400 kHz, 500 kHz, 625 kHz, 800 kHz, 1 MHz, 1.25 MHz, 2.5 MHz, 3.125 MHz, 4 MHz, 6 MHz, 6.25 MHz, 10 MHz, 12.5 MHz, 20 MHz, 25 MHz, 33.33 MHz, 50 MHz
Output driver type	Push-pull (active drive)
Absolute voltage range	-0.5 V to +5.5 V with respect to GND
Power-on state	Tri-state with weak (40 k Ω) pull down to GND
Transfer size	4 bits to 64 bits, software selectable

Bit ordering	Most significant bit (msb) first
--------------	----------------------------------

SPI specifications under different logic levels

Output Specifications			
Logic Family	Voltage Low Level (V_{OL}) (Full Temperature)	Voltage High Level (V_{OH}) (Full Temperature)	Output Drive Strength (I_{O_MAX})
	Max ($I_{OL} = 100 \mu A$)	Min ($I_{OH} = 100 \mu A$)	Max
1.2 V	0.2 V	1.0 V	± 3 mA
1.5 V	0.2 V	1.3 V	± 6 mA
1.8 V	0.2 V	1.6 V	± 8 mA
2.5 V	0.2 V	2.3 V	± 9 mA
3.3 V	0.2 V	3.1 V	± 12 mA
Output Impedance	70 Ω (typical)		

Input Specifications		
Logic Family	Input Voltage Low (V_{IL}) Max	Input Voltage High (V_{IH}) Min
1.2 V	0.42 V	0.78 V
1.5 V	0.525 V	0.975 V
1.8 V	0.63 V	1.17 V
2.5 V	0.7 V	1.6 V
3.3 V	0.8 V	2 V
Input Impedance	High impedance	
Input Protection	-0.5 V to +5.5 V, ± 50 mA maximum	

SPI timing requirements

Timing Parameter ¹	Min	Max	Unit
t_{clk} SCLK period	20	—	ns
t_{clkL} SCLK low time	9	—	ns
t_{clkH} SCLK high time	9	—	ns
t_{skew} MOSI output skew (with regard to SCLK edge)	-2	2	ns
t_1 MISO hold time	5	—	ns
t_2 MISO setup time	4	—	ns

¹ All timing parameters are measured/required at IDC connector.

SPI timing diagram

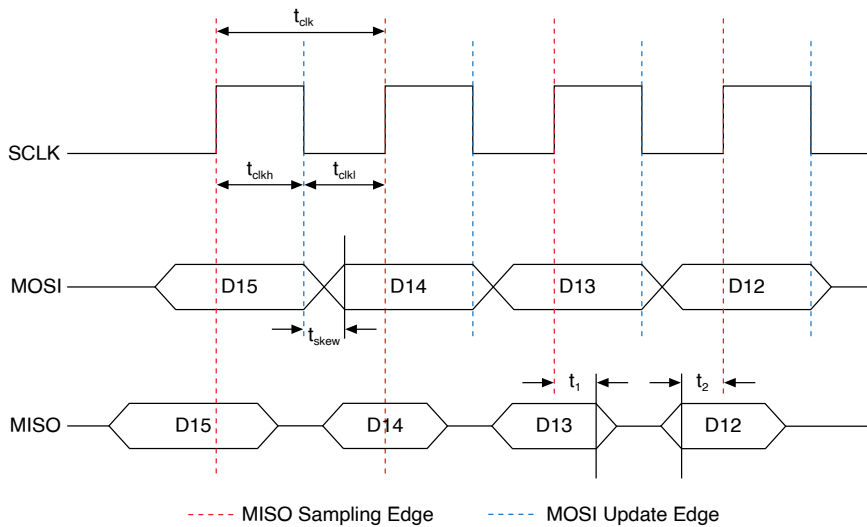

I²C Interface

Signals	
SDA	Output/input

SCL	Output/input
Supported clock rates (Master Mode)	
I ² C Standard Mode	16 kHz, 20 kHz, 25 kHz, 31 kHz, 40 kHz, 50 kHz, 62 kHz, 80 kHz, 100 kHz
I ² C Fast Mode	125 kHz, 200 kHz, 250 kHz, 400 kHz
I ² C Fast Mode Plus	500 kHz, 1 MHz
I ² C High Speed Mode	1.11 MHz, 1.33 MHz, 2.22 MHz, 3.33 MHz
Supported clock rates (Slave Mode)	Up to 3.4 MHz ^[1]
Output driver type	Open-drain
Absolute voltage range	-0.5 V to +5.5 V with respect to GND
Absolute input current	40 mA max
Power-on state	High impedance without pull-up

I²C I/O specifications under different logic levels

Logic Family	Output Voltage Low (V _{OL}) Max	Input Voltage Low (V _{IL}) Max
1.2 V	0.2 V	0.4 V

Logic Family	Output Voltage Low (V_{OL}) Max	Input Voltage Low (V_{IL}) Max
1.5 V	0.2 V	0.4 V
1.8 V	0.2 V	0.4 V
2.5 V	0.2 V	0.4 V
3.3 V	0.2 V	0.4 V
Pull-up current	3 mA (max) ¹	
Onboard capacitance	70 pF (max)	
Input protection	40 mA (max)	

¹ With onboard pull-up resistors enabled (tested under $V_{OL} = 0.24$ V)



Note This interface is compatible with both I²C and SMBus devices. (SMBus compatibility is only under $V_{ref} = 3.3$ V and using external pull-up resistors instead of onboard pull-ups. For a proper pull-up value, refer to the SMBus specifications.)

Bus Interface

USB specification	USB 2.0 High-Speed (480 Mb/s)
-------------------	-------------------------------

Power Requirements

USB high-power bus-powered device	
Input voltage	4.5 V min, 5.25 V max
Working mode current	500 mA maximum, 250 mA typical
USB Suspend	2.5 mA maximum (all front I/O lines disconnected)

Output Voltage Sources

+5 V output	
Voltage	4.75 V min, 5.25 V max
Current	20 mA max
Vref I/O reference output	
Voltage	1.2 V, 1.5 V, 1.8 V, 2.5 V, 3.3 V, with $\pm 10\%$ tolerance, software selectable
Current	20 mA max

Physical Characteristics

USB-8452

Dimensions	7.26 cm \times 9.19 cm \times 2.03 cm (2.86 in. \times 3.62 in. \times 0.8 in.)
I/O connectors	1 \times right angle USB series B receptacle, 1 \times right angle male IDE cable receptacle
Weight	79 g (2.8 oz)

USB-8452 OEM

Dimensions	6.65 cm \times 8.86 cm (2.62 in. \times 3.49 in.)
------------	---

I/O connectors	1 × right angle USB series B receptacle, 1 × right angle male IDE cable receptacle
Weight	35 g (1.23 oz)

Dimensional drawings

Figure 1. USB-8452 OEM Dimensions (Top View)

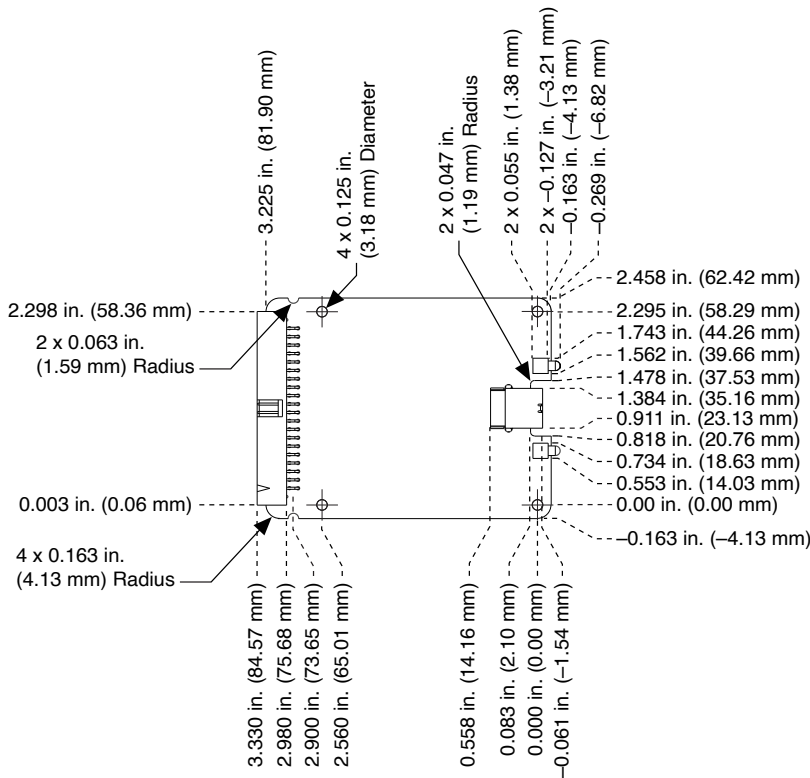
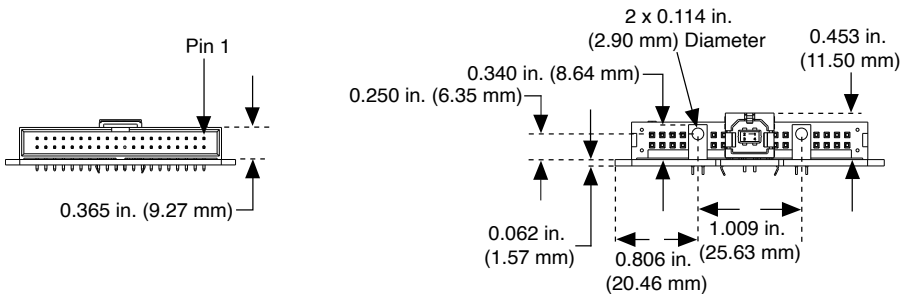

Figure 2. USB-8452 OEM Dimensions (Front and Rear Views)



Safety

Safety Standards

This product is designed to meet the requirements of the following standards of safety for information technology equipment:

- IEC 61010-1, EN 61010-1
- UL 61010-1, CSA 61010-1



Note For UL and other safety certifications, refer to the product label or the [Product Certifications and Declarations](#) section.

Hazardous Locations

The NI USB-845X modules are not certified for use in hazardous locations.

Electromagnetic Compatibility

USB-8452

This product meets the requirements of the following EMC standards for electrical equipment for measurement, control, and laboratory use:

- EN 61326 (IEC 61326): Class A emissions; Basic immunity
- EN 55011 (CISPR 11): Group 1, Class A emissions
- AS/NZS CISPR 11: Group 1, Class A emissions
- FCC 47 CFR Part 15B: Class A emissions
- ICES-001: Class A emissions

USB-8452 OEM

The USB-8452 OEM device is intended for use as part of a system. To ensure that your system meets the appropriate EMC standards, you must test the entire system.



Note For EMC declarations and certifications, and additional information, refer to the ***Online Product Certification*** section.



Note For EMC compliance, operate this product according to the documentation.

CE Compliance

USB-8452

This product meets the essential requirements of applicable European Directives, as follows:

- 2014/35/EU; Low-Voltage Directive (safety)
- 2014/30/EU; Electromagnetic Compatibility Directive (EMC)

USB-8452 OEM

The USB-8452 OEM device is intended for use as part of a system. To ensure that your system meets the appropriate CE Compliance regulations, you must test the entire system.

Product Certifications and Declarations

Refer to the product Declaration of Conformity (DoC) for additional regulatory compliance information. To obtain product certifications and the DoC for NI products, visit ni.com/product-certifications, search by model number, and click the appropriate link.

Environmental

The NI USB-845X modules are intended for indoor use only.

Operating temperature (IEC 60068-2-1 and IEC 60068-2-2)	0 °C to 45 °C
Operating humidity (IEC 60068-2-56)	10% to 90% RH, noncondensing

Maximum altitude	2,000 m (at 25 °C ambient temperature)
Storage temperature (IEC 60068-2-1 and IEC 60068-2-2)	-40 °C to 85 °C
Storage humidity (IEC 60068-2-56)	5% to 90% RH, noncondensing
Pollution Degree (IEC 60664)	2

Environmental Management

NI is committed to designing and manufacturing products in an environmentally responsible manner. NI recognizes that eliminating certain hazardous substances from our products is beneficial to the environment and to NI customers.

For additional environmental information, refer to the ***Engineering a Healthy Planet*** web page at ni.com/environment. This page contains the environmental regulations and directives with which NI complies, as well as other environmental information not included in this document.

EU and UK Customers

-  **Waste Electrical and Electronic Equipment (WEEE)**—At the end of the product life cycle, all NI products must be disposed of according to local laws and regulations. For more information about how to recycle NI products in your region, visit ni.com/environment/weee.

电子信息产品污染控制管理办法（中国RoHS）

-  **中国RoHS**—NI符合中国电子信息产品中限制使用某些有害物质指令 (RoHS)。关于NI中国RoHS合规性信息，请登录 ni.com/environment/rohs_china。(For information about China RoHS compliance, go to ni.com/environment/rohs_china.)

371746E-01