



TAOGLAS®



Datasheet

Multiband High Precision GNSS Stacked Patch Antenna

Part No:
GPDF5012.A

Description:

Passive Multiband High Precision GNSS Stacked Patch Antenna

Features:

Bands Covered:

- GPS (L1/L2/L5)
- IRNSS (L5)
- QZSS (L1/L2C/L5)
- Galileo (E1/E5a/E5b)
- GLONASS (G1/G2/G3)
- BeiDou (B1/B2a/B2b)

Dual pin, dual feed, 4-pin configuration

Dimensions: 50 x 50 x 12mm

RoHS & Reach Compliant

1. Introduction	3
2. Specifications	4
3. Antenna Characteristics (with hybrid coupler)	6
4. Radiation Patterns	11
5. Field Test Data	17
6. Mechanical Drawing	19
7. Evaluation Board Mechanical Drawing	20
8. Antenna Integration Guide	21
9. Packaging	28
<hr/>	
Changelog	29

Taoglas makes no warranties based on the accuracy or completeness of the contents of this document and reserves the right to make changes to specifications and product descriptions at any time without notice. Taoglas reserves all rights to this document and the information contained herein. Reproduction, use or disclosure to third parties without express permission is strictly prohibited.



1. Introduction



The Taoglas **GPDF5012.A** is a high performance, multi-band passive GNSS antenna that has been carefully designed to provide fantastic positional accuracy on the full GNSS spectrum. It covers GPS/QZSS L1/L2/L5, GLONASS G1/G2/G3, Galileo E1/E5a/E5b, BeiDou B1/B2a/B2b, NAVIC L5, as well as SBAS (WAAS/EGNOS/GAGAN/SDCM/SNAS).

Correct implementation of the GPDF5012.A allows the user to achieve higher location accuracy, as well as stability of position tracking in urban environments. The stacked patch construction has excellent performance across the full bandwidth of the antenna. Its design has an even gain across the hemisphere, giving excellent axial ratio, which in turn makes it extremely resilient to multipath rejection and provides excellent phase centre stability.

Typical applications that benefit from high precision capabilities include:

- Autonomous Driving
- Precision Positioning for Robotics
- Precision Agriculture
- Telematics & Container / Asset Tracking
- Timing Accuracy Synchronization



The GPDF5012.A is the latest embedded addition to Taoglas' product portfolio of high precision GNSS antennas. When used on the base and/or the rover as part of an RTK configuration, the GPDF5012.A can achieve genuine cm-level accuracy with proven results.

Full integration guidelines are contained in Section 8 of this datasheet including the Taoglas **HC125.A** hybrid coupler that will be required for use for dual pin feed patch integrations. An active version of this antenna, the **ADFGP.50A.07.0100C** is available and supplied with 100mm cable and I-PEX MHFI connector as standard.

Contact your local Taoglas Customer Services team for more information on any of the products listed above or for support regarding integration.

2. Specifications

GNSS Frequency Bands Covered							
GPS	L1	L2	L5				
	■	■	■				
GLONASS	G1	G2	G3				
	■	■	■				
Galileo	E1	E5a	E5b	E6			
	■	■	■	□			
BeiDou	B1	B2a	B2b	B3			
	■	■	■	□			
QZSS (Regional)	L1	L2C	L5	L6			
	■	■	■	□			
IRNSS (Regional)	L5						
	■						
SBAS	L1/E1/B1	L5/B2a/E5a	G1	G2	G3		
	■	■	■	■	■		

*SBAS systems: WASS(L1/L5), EGNOS(E1/E5a), SDCM(G1/G2/G3), SNAS(B1,B2a), GAGAN(L1/L5), QZSS(L1/L5), KAZZ(L1/L5).

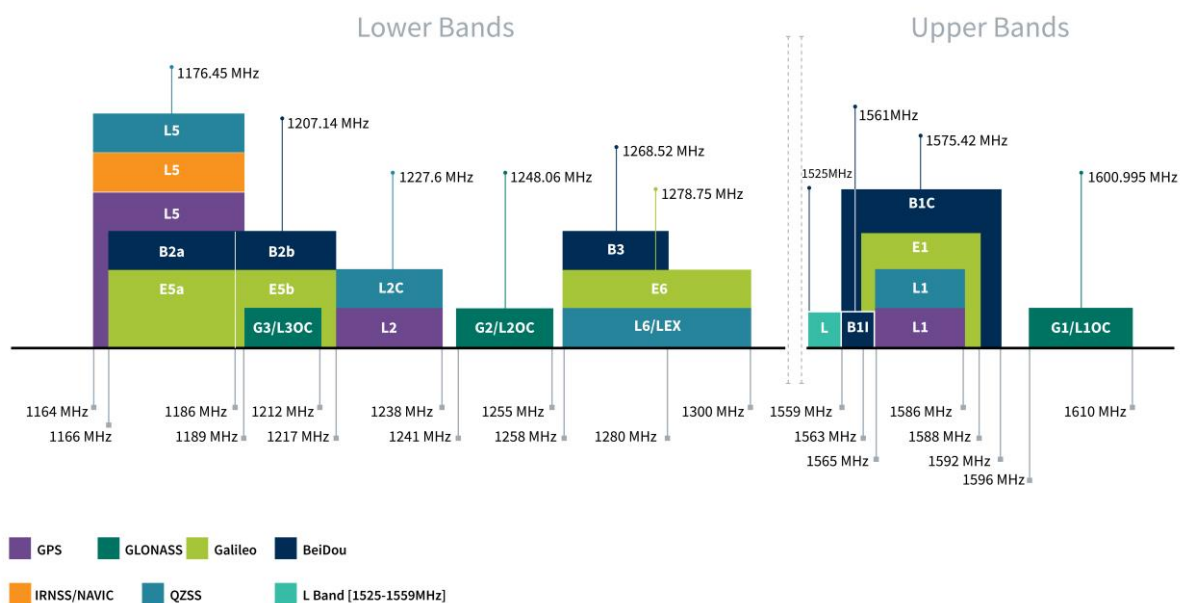

GNSS Bands and Constellations

GNSS Electrical					
Frequency (MHz)	1176.45	1227.6	1561	1575.42	1602
VSWR (max.)	1.5:1	1.5:1	1.5:1	1.5:1	1.5:1
Passive Antenna Efficiency (%)	27.6	30.6	51.2	65.3	68.6
Passive Antenna Gain at Zenith (dBi)	0.90	0.92	2.96	4.32	4.44
Axial Ratio (dB)	1.46	1.03	1.24	1.08	1.19
Group Delay (ns)	2.5	6	3	3	3
PCO (cm)	0.9	1.0	1.1	1.1	1.1
PCV (cm)	1.0	1.1	1.2	1.2	1.2
Polarization	RHCP				
Impedance	50Ω				

**Note: The antenna with Hybrid coupler was tested on a 70X70 mm ground plane
The PCO and PCV are calculated using a field of view of 60° elevation from zenith**

Mechanical	
Height	12.5 mm
Planner Dimension	50 x 50 mm diameter
Weight	86 g
Environmental	
Temperature Range	-40°C to 85°C
RoHS Compliant	Yes
REACH Compliant	Yes

3. Antenna Characteristics(with hybrid coupler)

3.1 L2_L5 - Return Loss (From Hybrid Couplers)

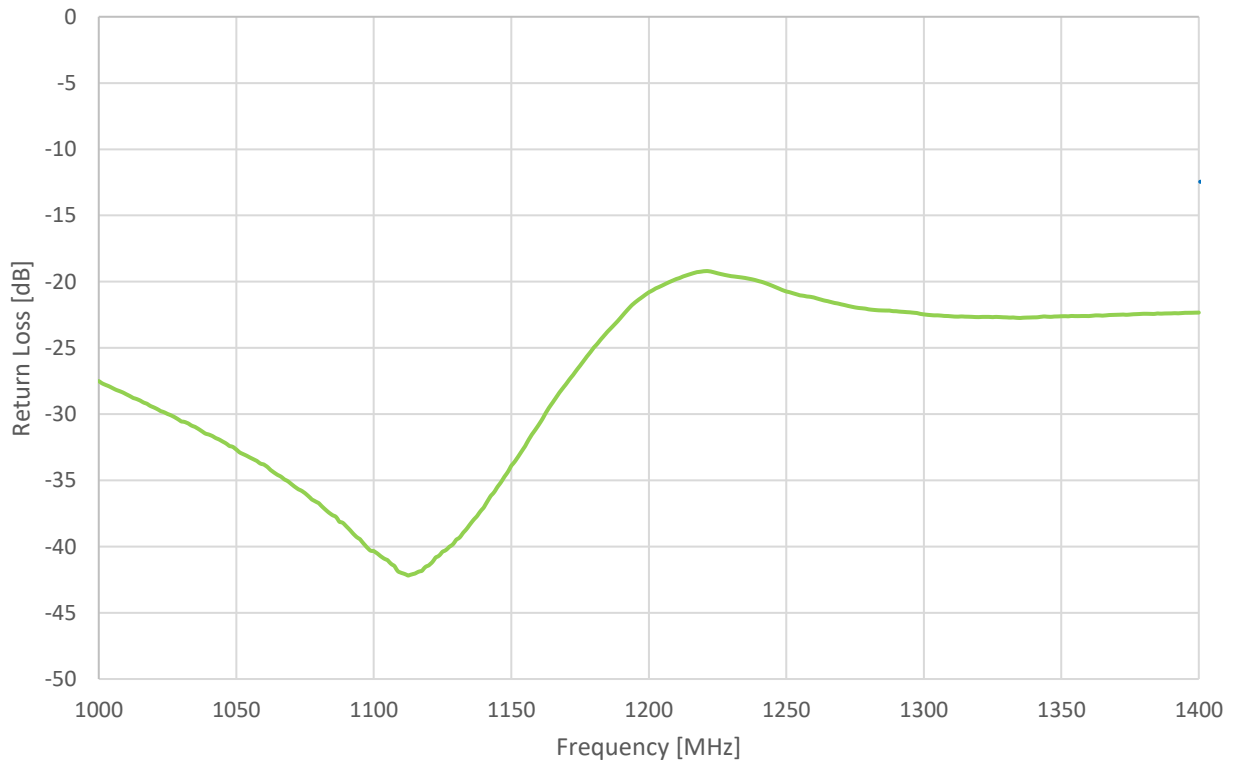

3.2 L1 - Return Loss (From Hybrid Couplers)

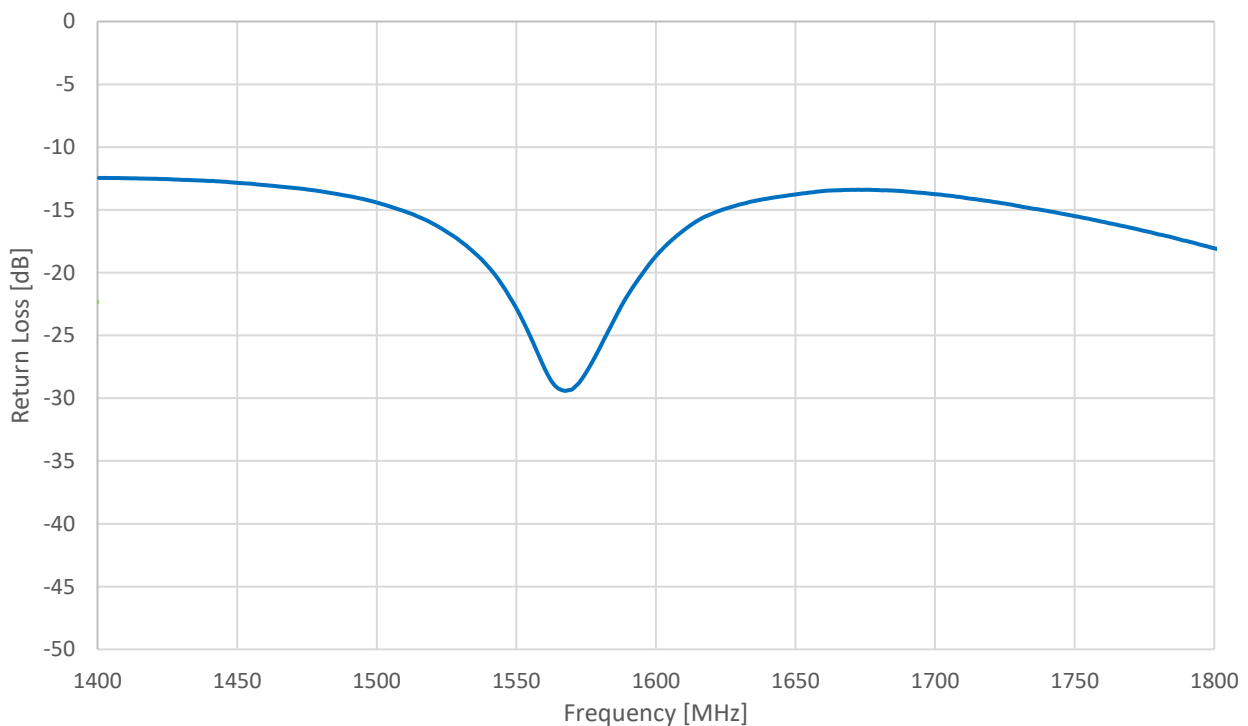

3.3 L2_L5 - Efficiency

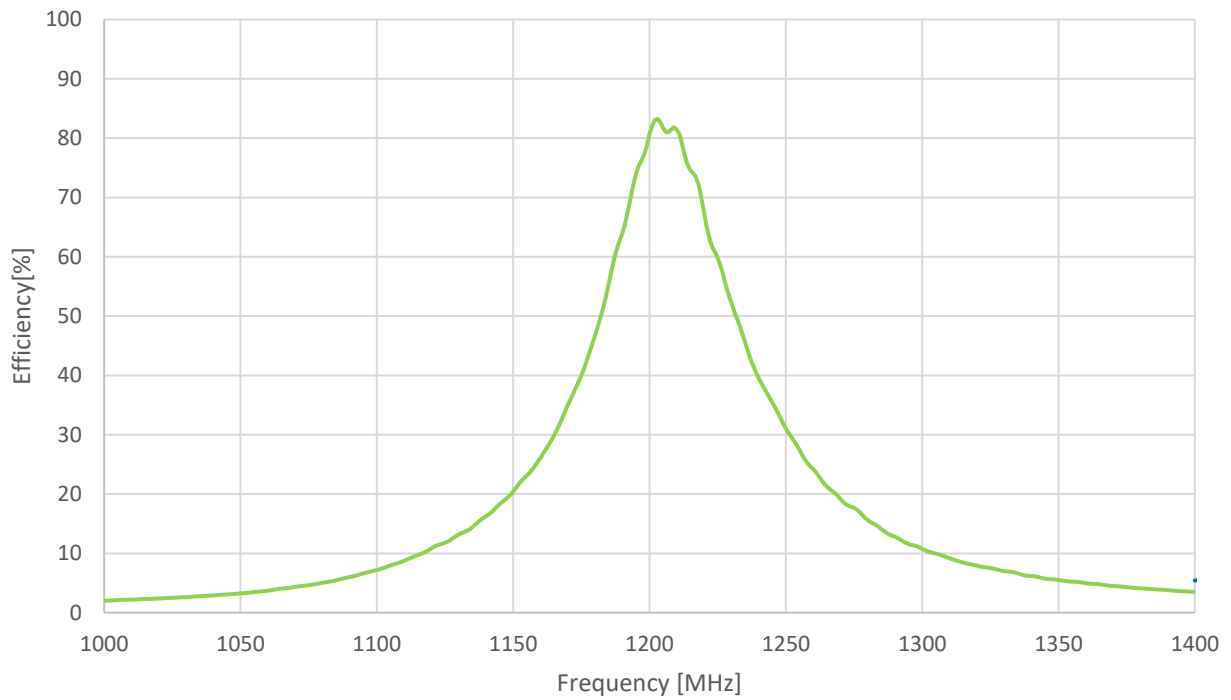

3.4 L1 - Efficiency

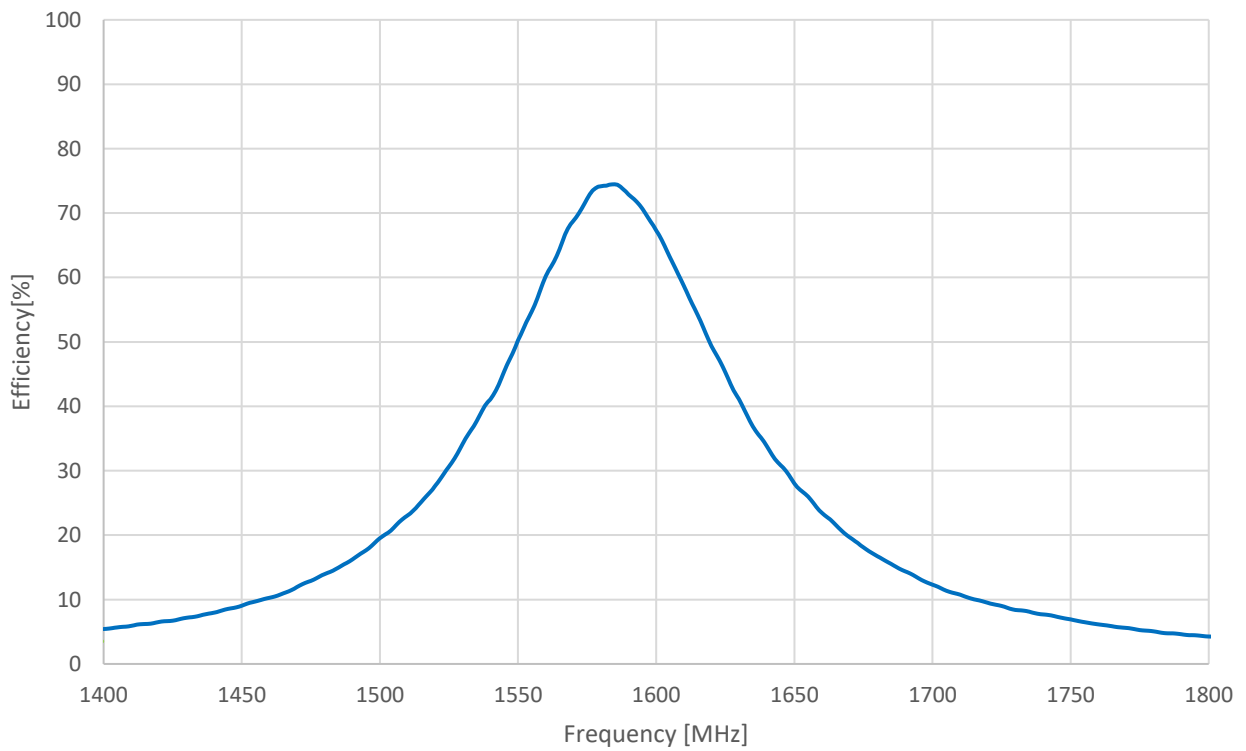

3.5 L2_L5 - Average Gain

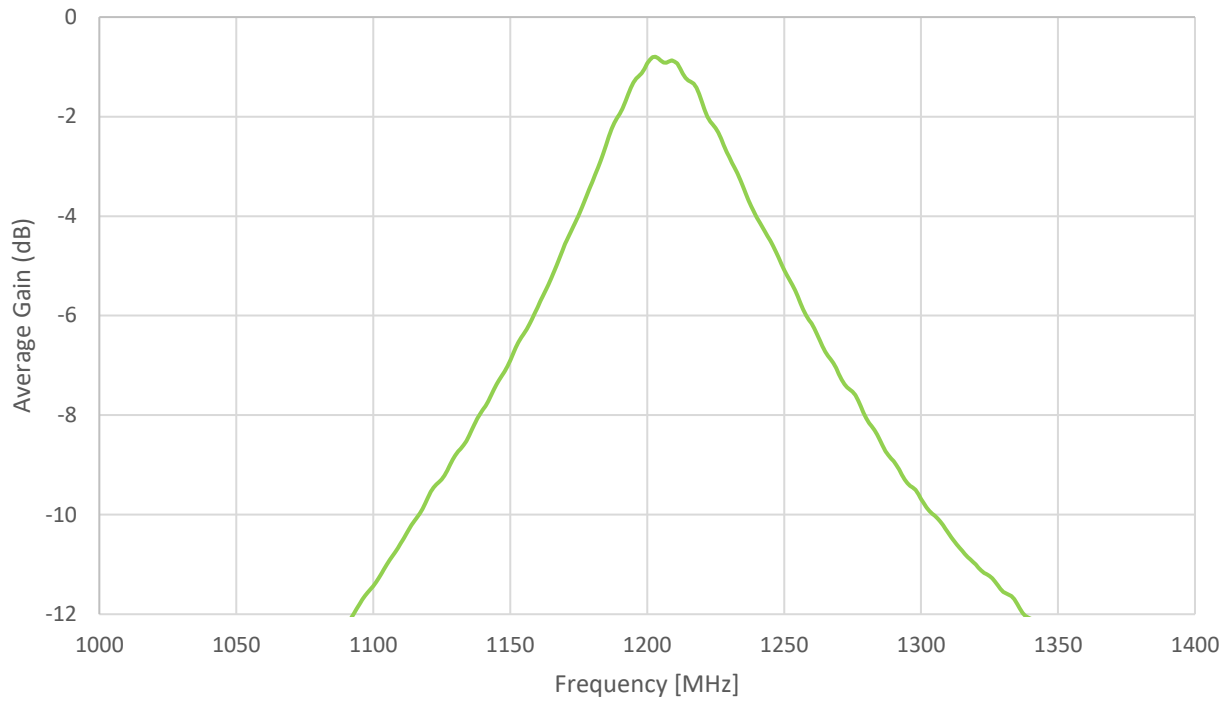

3.6 L1 - Peak Gain

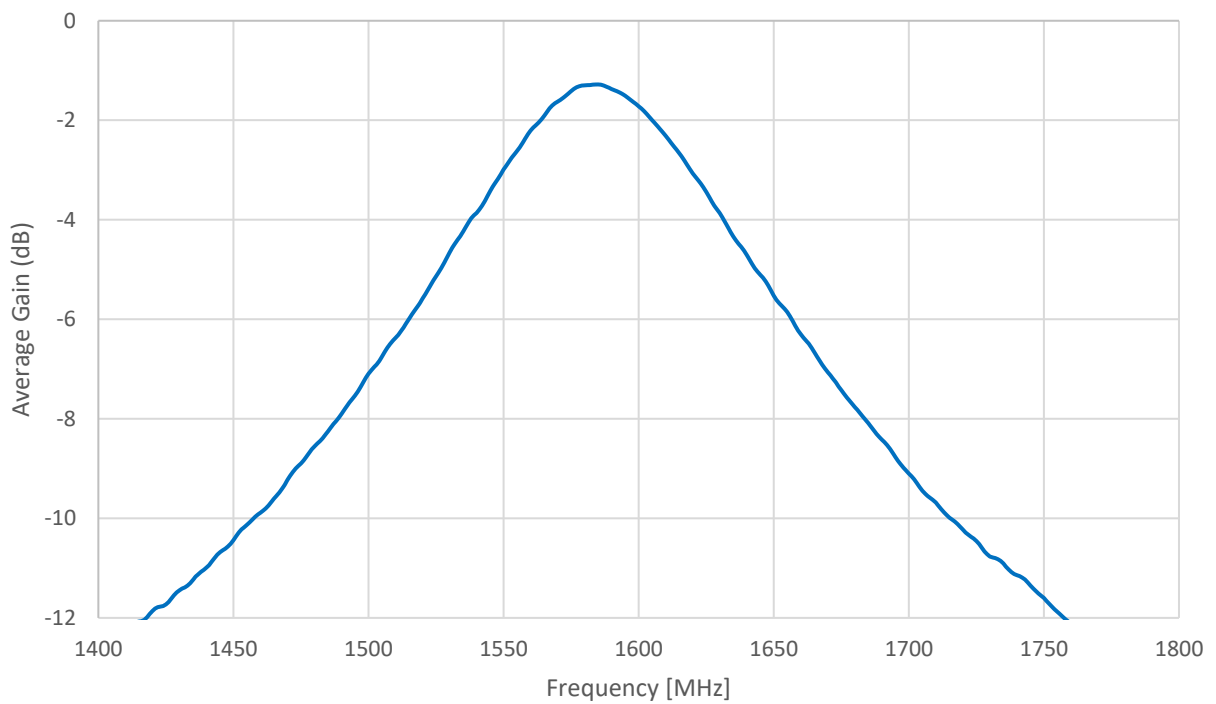

3.7 L2_L5 - Peak Gain

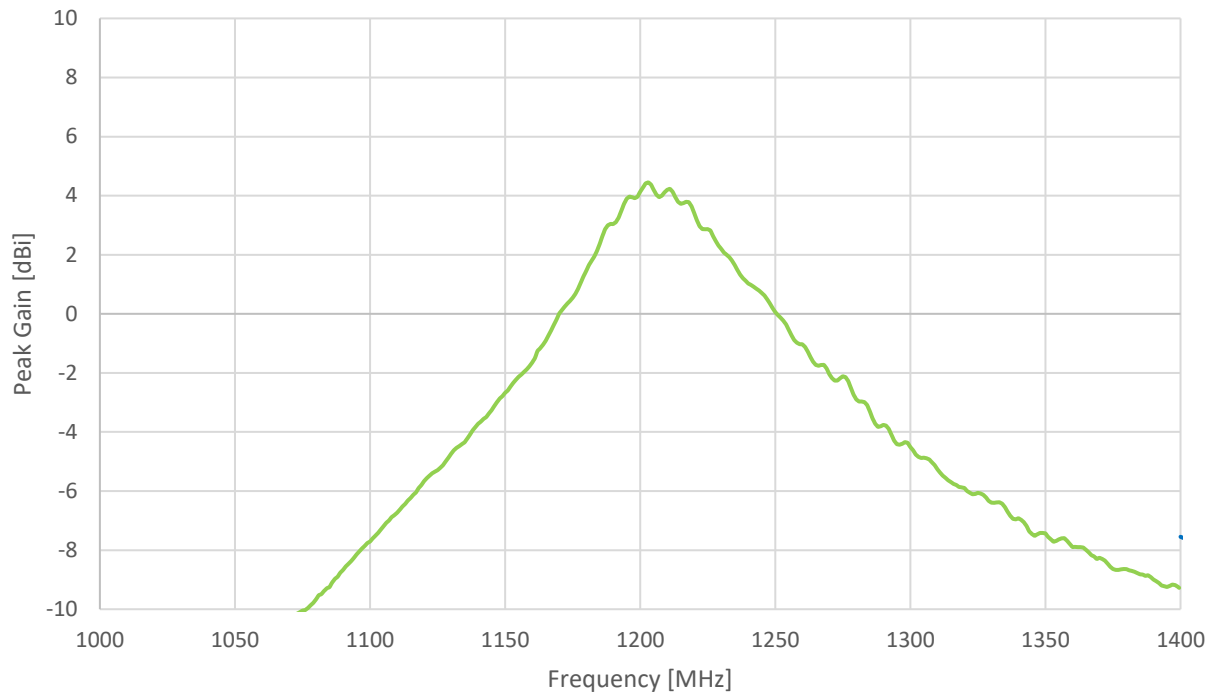

3.8 L1 - Peak Gain

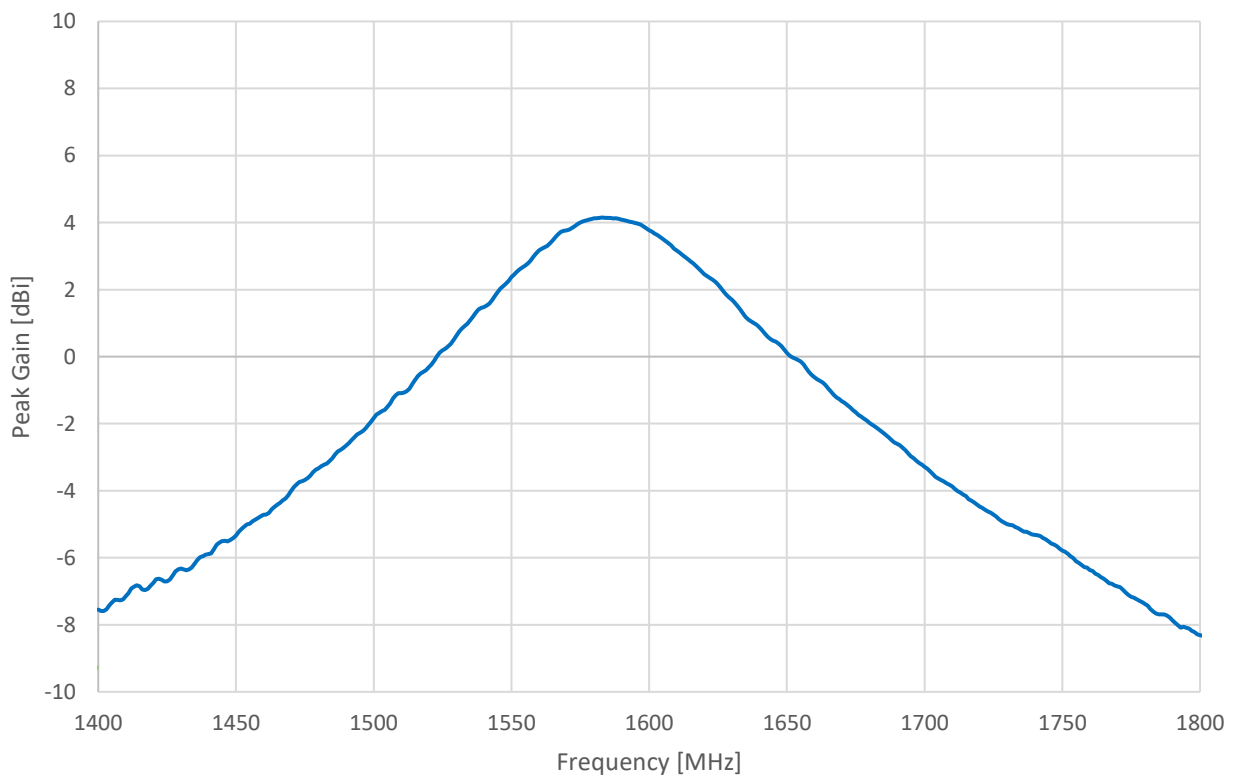

3.9 Axial Ratio

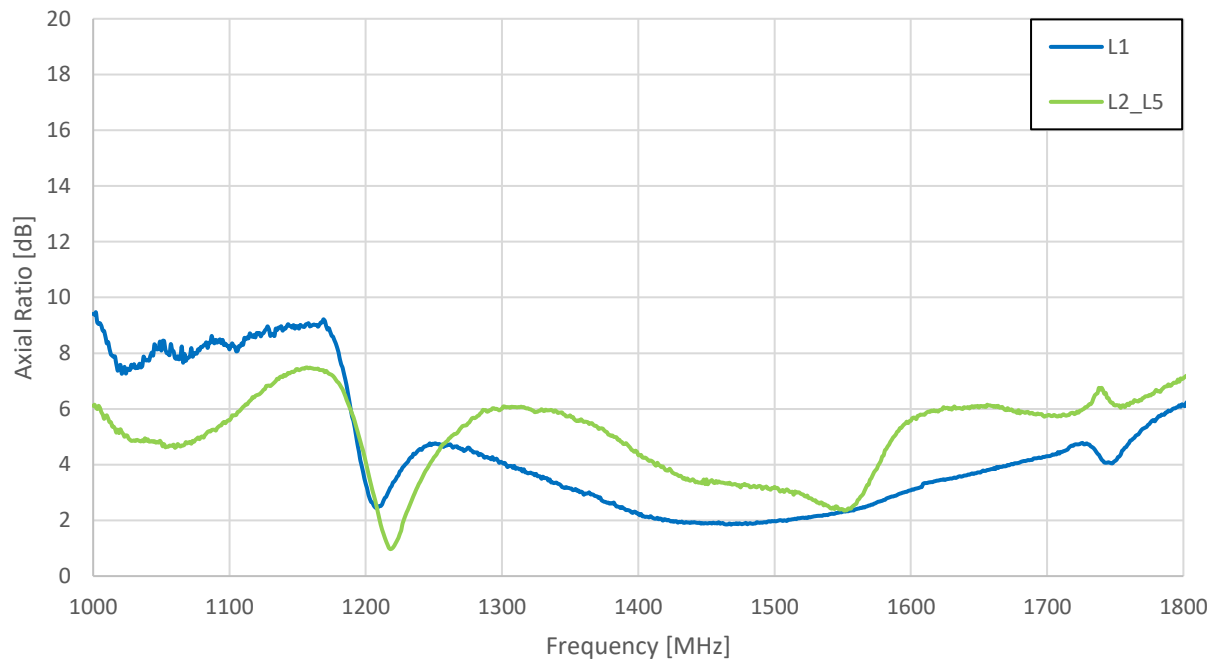

Phi=0

Phi=90

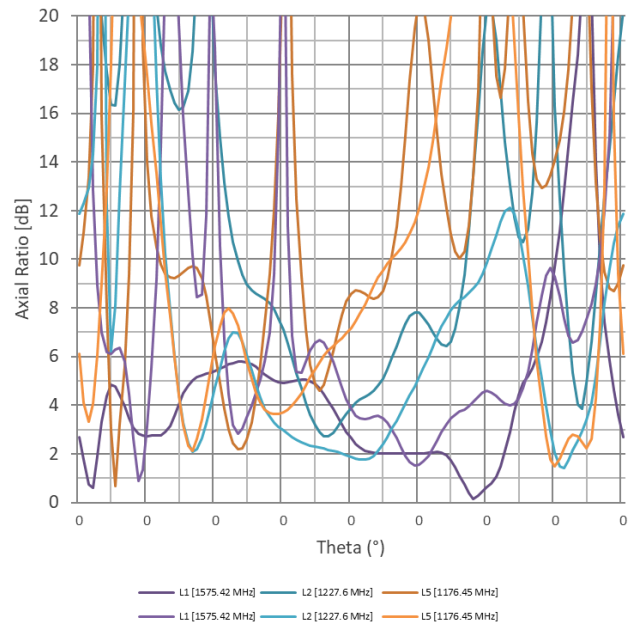
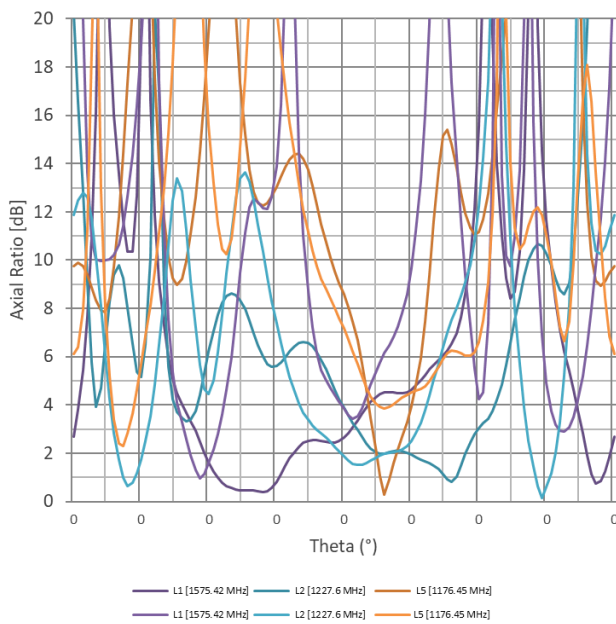

4. Radiation Patterns

4.1 Test Setup

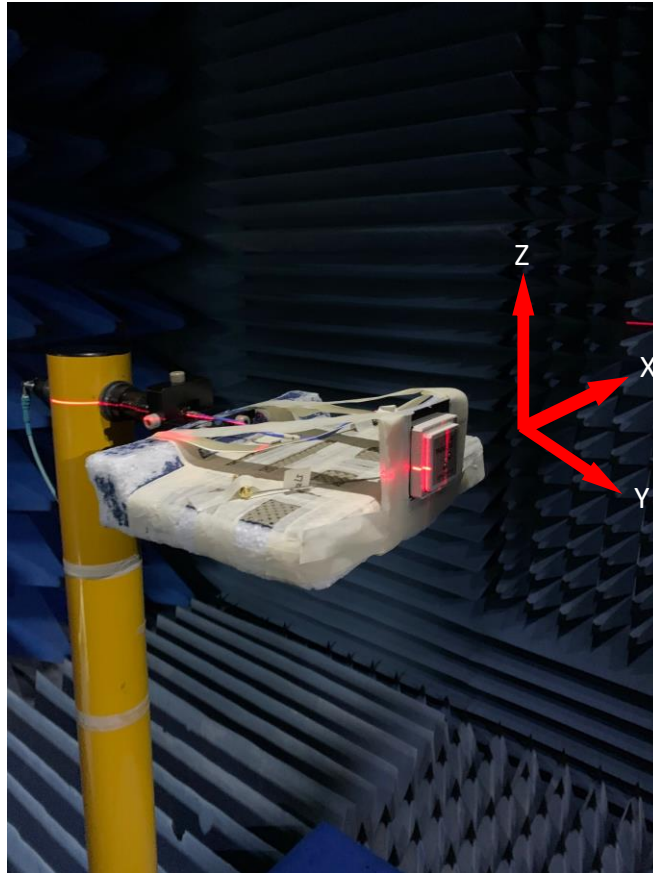

4.2 GNSS L1 Band 3D and 2D Radiation Patterns

Gain total, 1560MHz

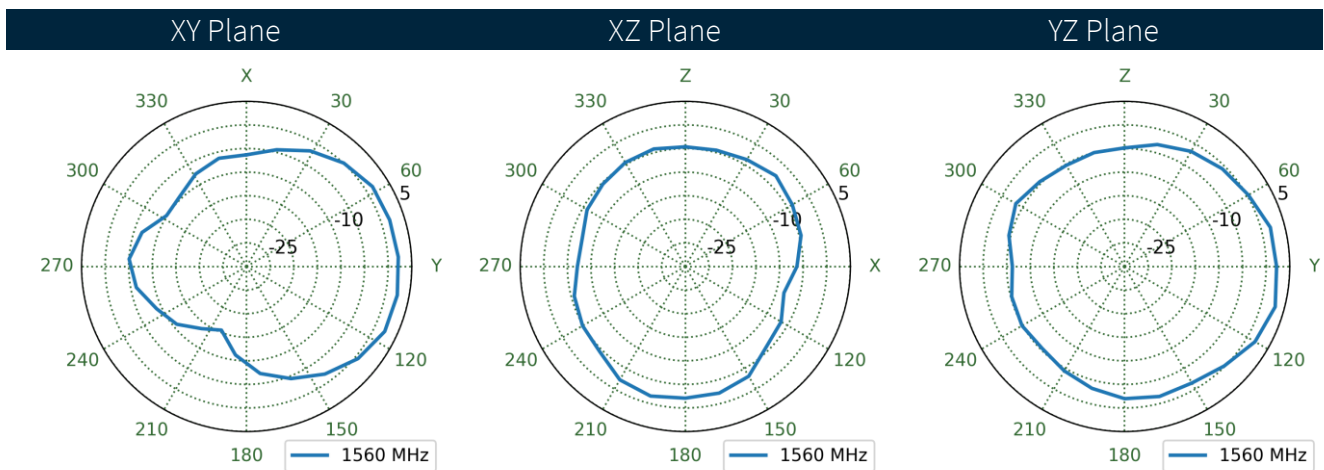
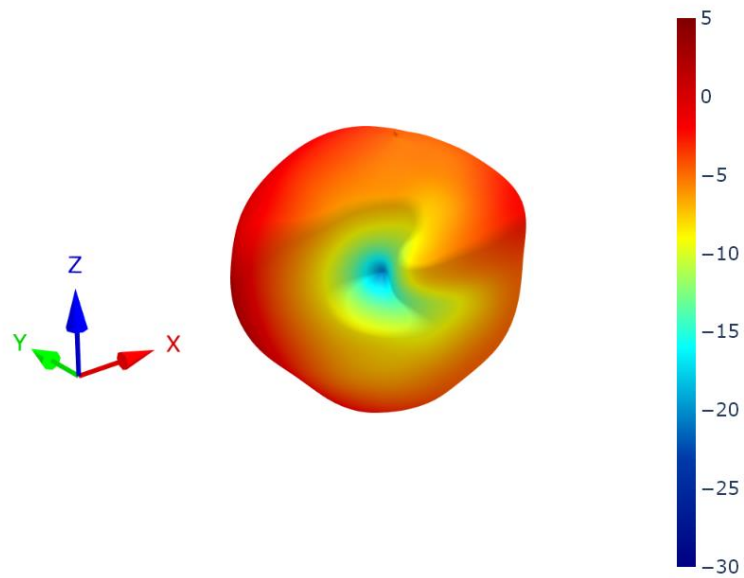

Gain total, 1575.42MHz

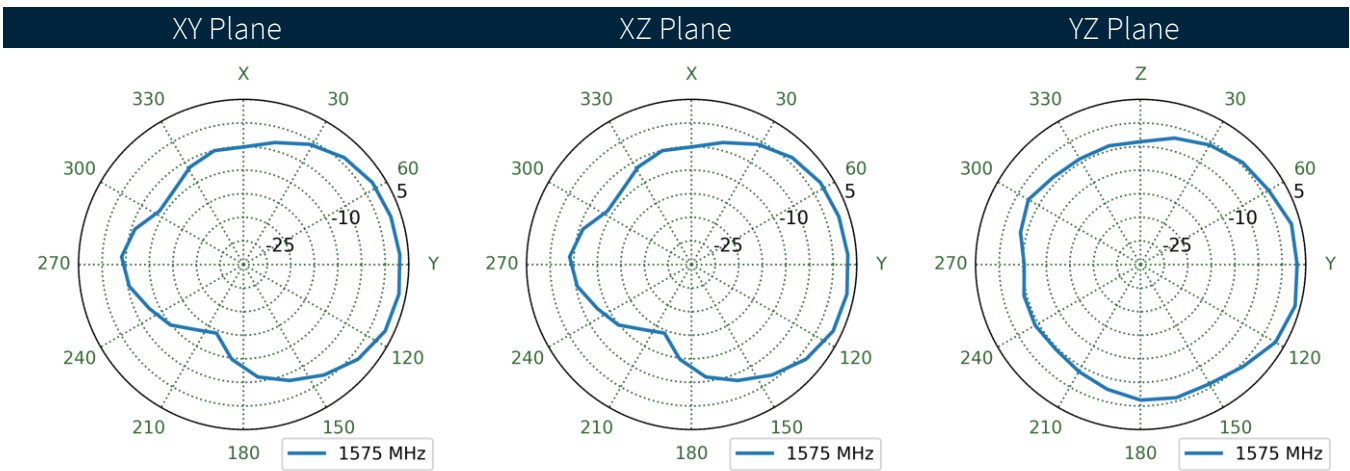
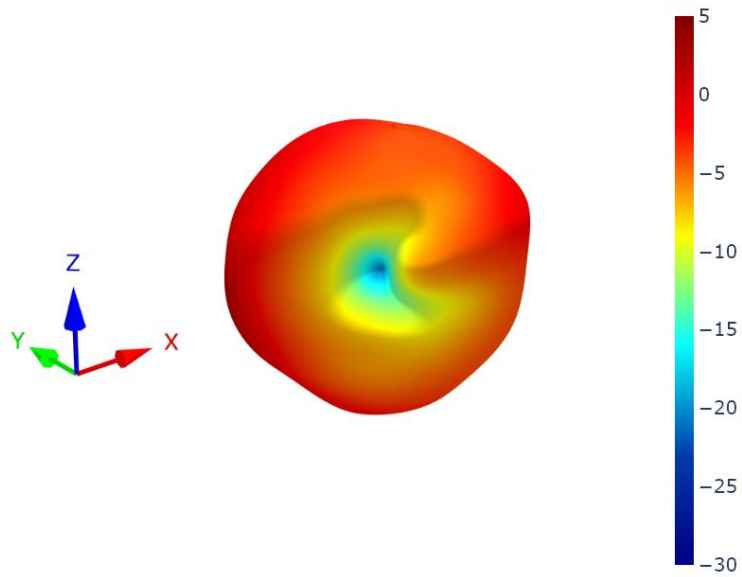

Gain total, 1600MHz

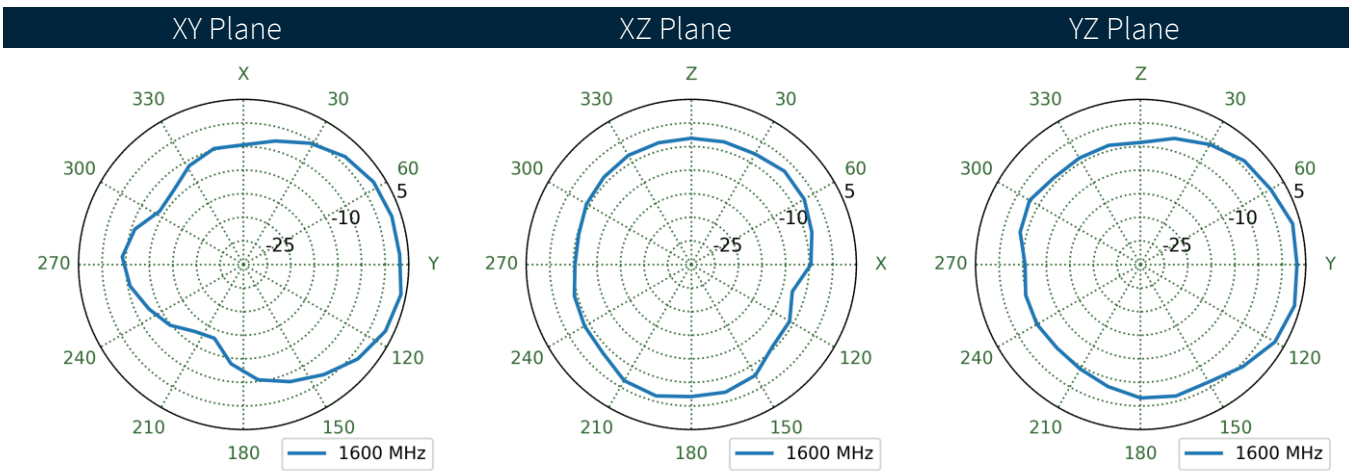
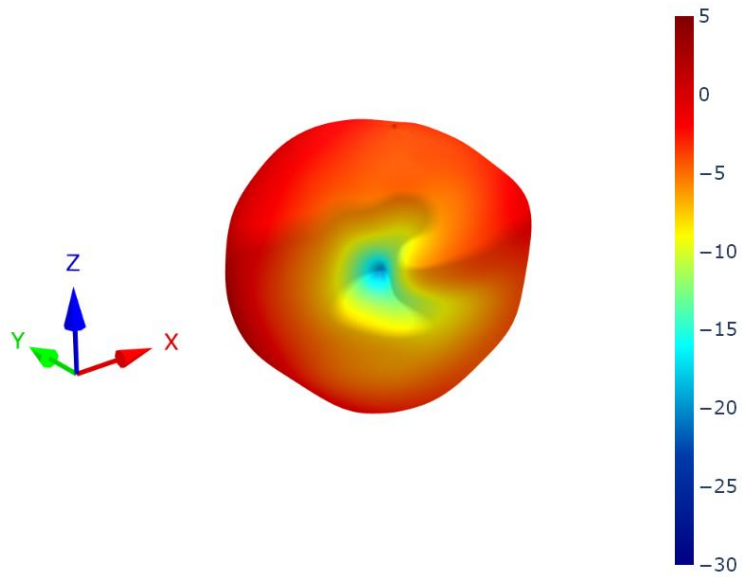

4.3 GNSS L2 L5 Band 3D and 2D Radiation Patterns

Gain total, 1177MHz

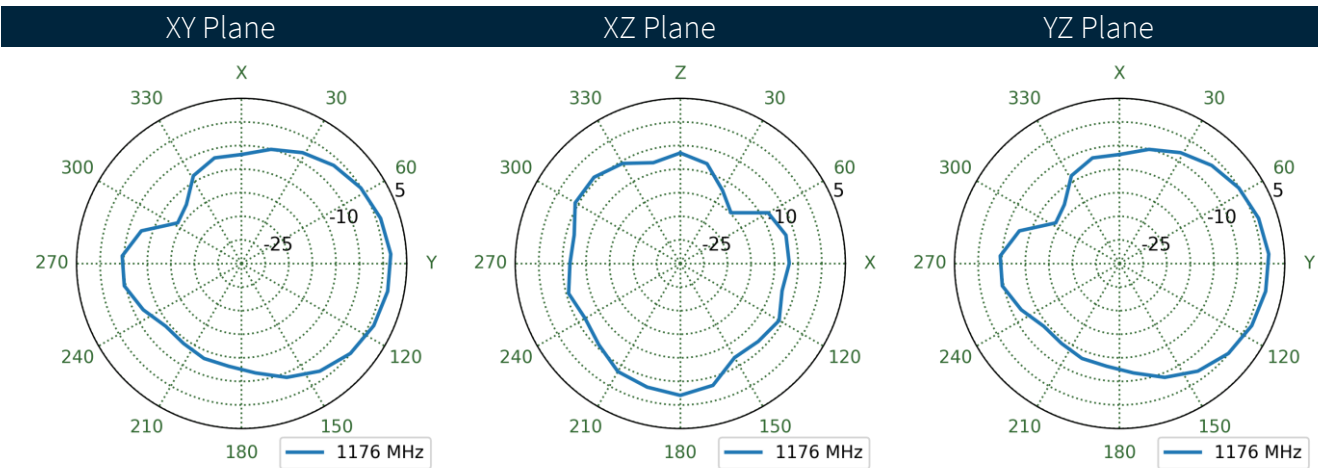
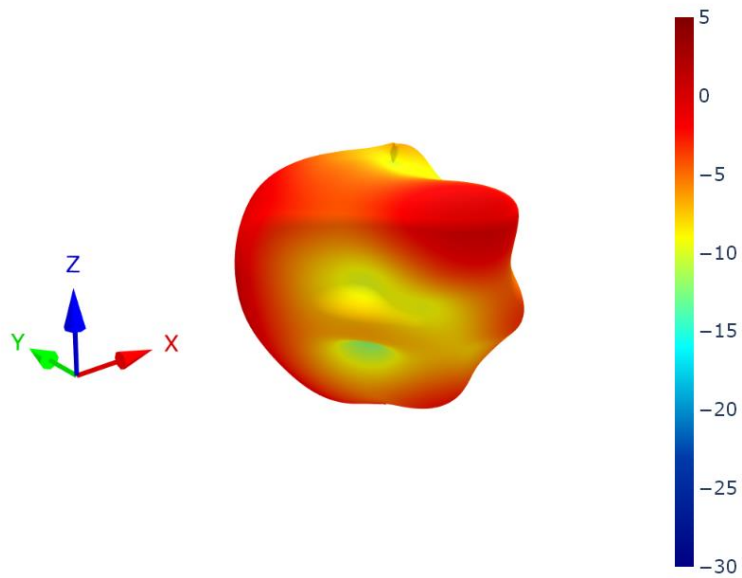

Gain total, 1228MHz

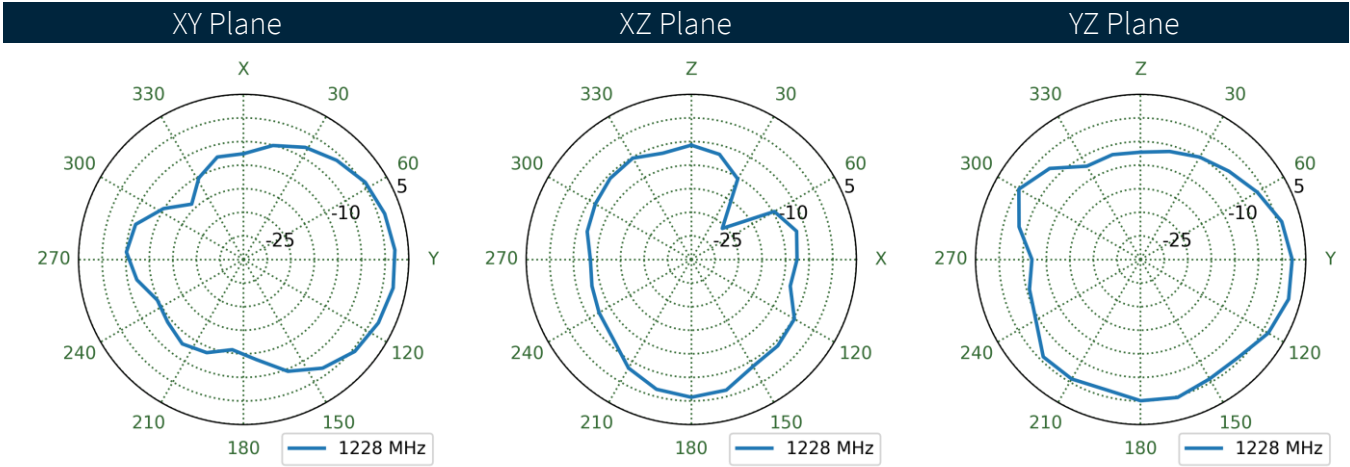
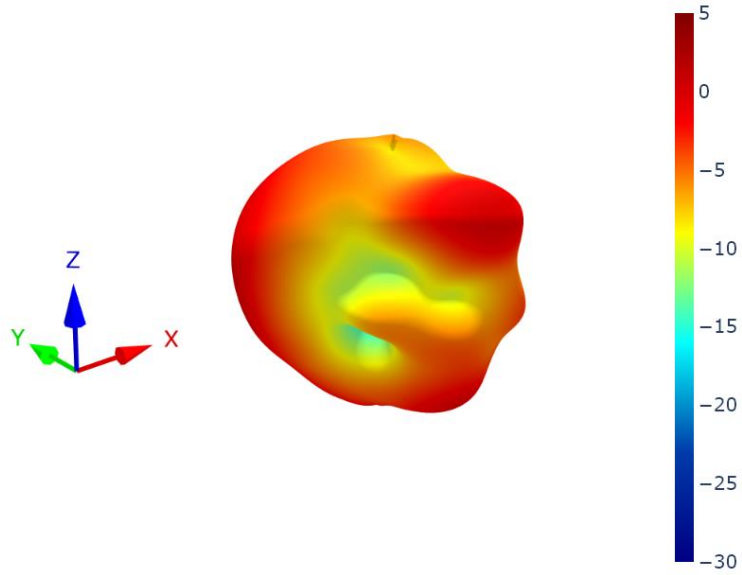

5. Field Test Results

This section outlines the field test result for GPDF5012.A antenna. The test was performed when the antenna was mounted on a static rooftop test set up in an open sky environment for a minimum of **6 hours**.

Taoglas will show the field test results using the following receivers:

5.1 Ublox ZED-F9P-0XB

Receiver features:

- Multi-band GNSS: 184-channel GPS L1C/A L2C, GLONASS: L1OF L2OF, Galileo: E1B/C E5b, BeiDou: B1I B2I, QZSS: L1C/A L2C
- Multi-band RTK with fast convergence times and reliable performance
- Nav. update rate RTK up to 20 Hz
- Position accuracy = RTK 0.01 m + 1 ppm CEP

Positioning Accuracy Table (2D Accuracy)					
Test Condition	DRMS(cm)	CEP (50%)	DRMS (68%)	2DRMS (95-98.2%)	TTF (sec)
70x70mm Ground Plane	RTK DISABLED	46.6	56.4	112.8	32
	RTK ENABLED	1.0	1.2	2.4	32

RTK Availability
70x70 mm ground plane

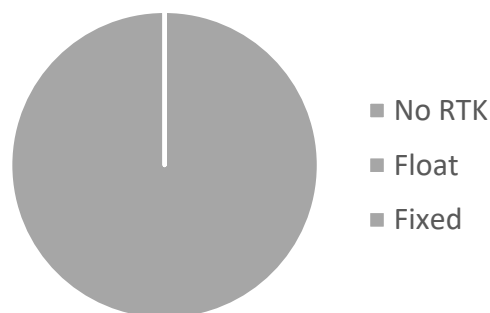

5.2 Ublox NEO-F9P-15B

Receiver features:

- Multi-band GNSS: GPS / QZSS (L1C/A, L5) GLONASS (L1OF) Galileo (E1-B/C, E5a) BeiDou (B1I, B2a) NavIC (SPS-L5)
- Multi-band PPP-RTK with fast convergence times and reliable performance
- Nav. update rate RTK up to 25 Hz
- Position accuracy = RTK 0.01 m + 1 ppm CEP

Positioning Accuracy Table (2D Accuracy)					
Test Condition	DRMS(cm)	CEP (50%)	DRMS (68%)	2DRMS (95-98.2%)	TTF (sec)
70x70mm Ground Plane	PPP-RTK DISABLED	103.19	123.52	247.06	27
	PPP-RTK ENABLED	16.7	20.04	40.08	33

*The RTK correction service used in previous measurements provides superior corrections compared to the PPP-RTK service used for measurements on the NEO-F9P.

PPP-RTK Availability 70x70 mm ground plane

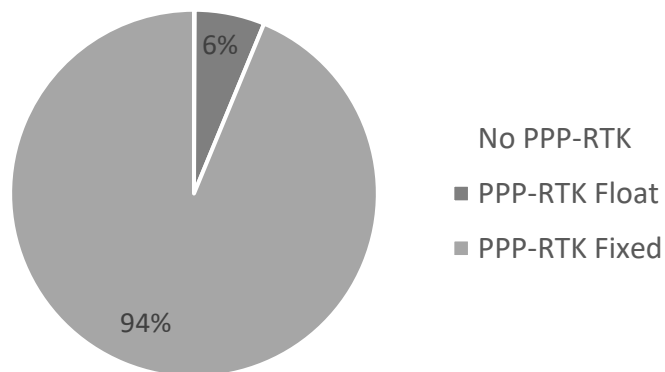

6. Mechanical Drawing (Units: mm)

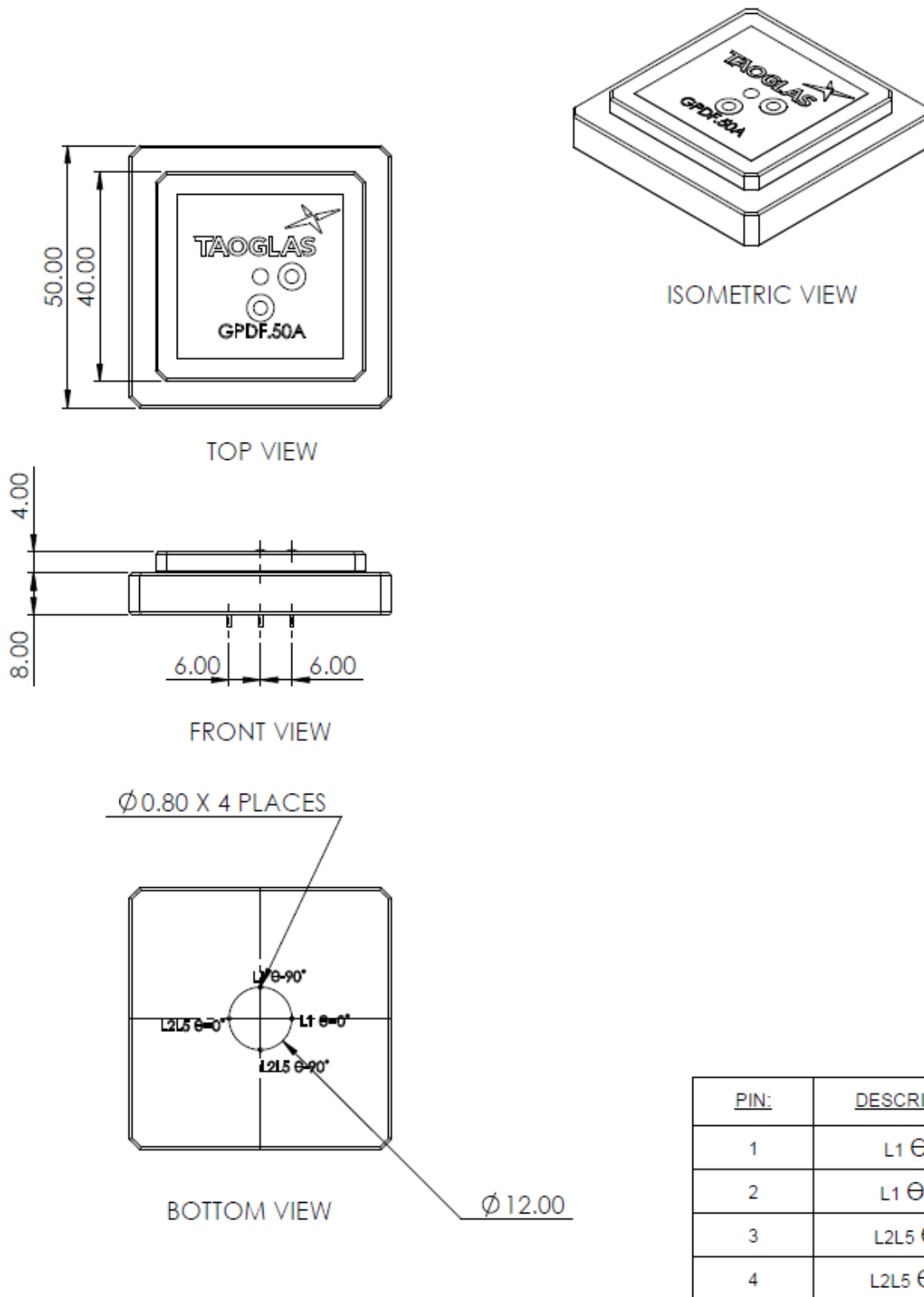

7. Evaluation Board Drawing (Units: mm)

ISO NO.: EDW-20-8-0504

STATE: Release

NOTES: 2. Soldermask Area: 3. Adhesive Tape: 4. Silver:

REV.	DESCRIPTION	ENG.	APPROVED	DATE
001	Initial Design	Mickey	Buluto	2020/05/25

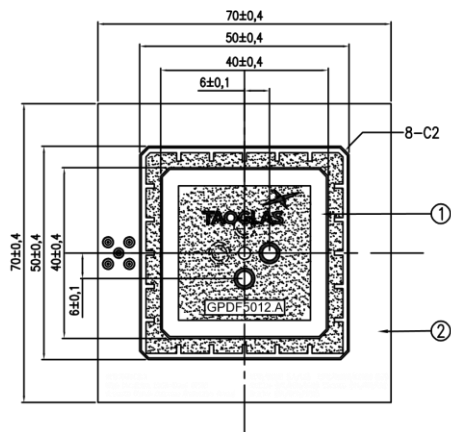

Top

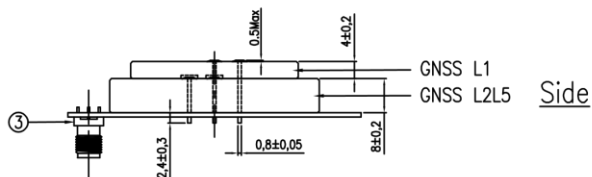

Side

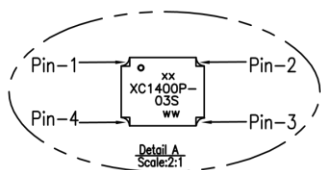

Detail A
Scale:2:1

	Configuration	Pin-1	Pin-2	Pin-3	Pin-4
1	GNSS L1	Output	Isolated	∅8	∅8-90
2	GNSS L2L5	Output	Isolated	∅8	∅8-90

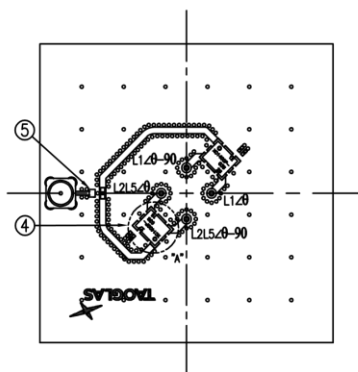

Bottom

	Name	P/N	Material	Finish	QTY
1	GPDF5012A Patch 50x50x12mm	01348BA200A04D	Ceramic	Clear	1
2	PCB_70x70x1.0mm	02110213040100	FR-4	Black	1
3	SMA(V) Connector	02104220000040	Copper	Gold	1
4	Hybrid Coupler	02121140061010	-	Silver	2
5	Power Divider	02102NP0092210	-	Black	1

APPROVED BY: Buluto	TW Design Centre This drawing and its inherent design concepts are property of Taoglas. Not to be copied or given to third parties without the written consent of Taoglas.
CHECK BY: Amos	
DRAWN BY: Mickey	
DATE: 2020/05/25	TITLE : GNSS Dual Feed Stacked Patch Antenna L1:1575MHz L2:1227MHz L5:1176.45MHz 50*50*12mm with EV Board
UNLESS OTHERWISE SPECIFIED TOLERANCES ON: XX:±0,5 X:±0,3 J:±0,2 K:±0,1 XXX:±0,05	PART NO. : GPDFD5012.A
THIRD ANGLE PROJECTION	UNIT: mm SCALE: 1:1.5 PAGES: 1/1 REV. D01

8. Antenna Integration Guide



8.1 Schematic Symbol and Pin Definitions

The circuit symbol for the antenna is shown below. The antenna has 4 pins as indicated below. The L1P1 and L1P2 (Pin 1 and 2) represent the higher GNSS frequency bands at 1559 - 1610MHz and the L2P1 and L2P2 (Pin 3 and 4) represent the lower GNSS frequency bands at 1164 - 1300MHz, including L5, E5a and E5b bands.

Pin	Description
1	L1P1 (0°)
2	L1P2 (-90°)
3	L2P1 (0°)
4	L2P2 (-90°)

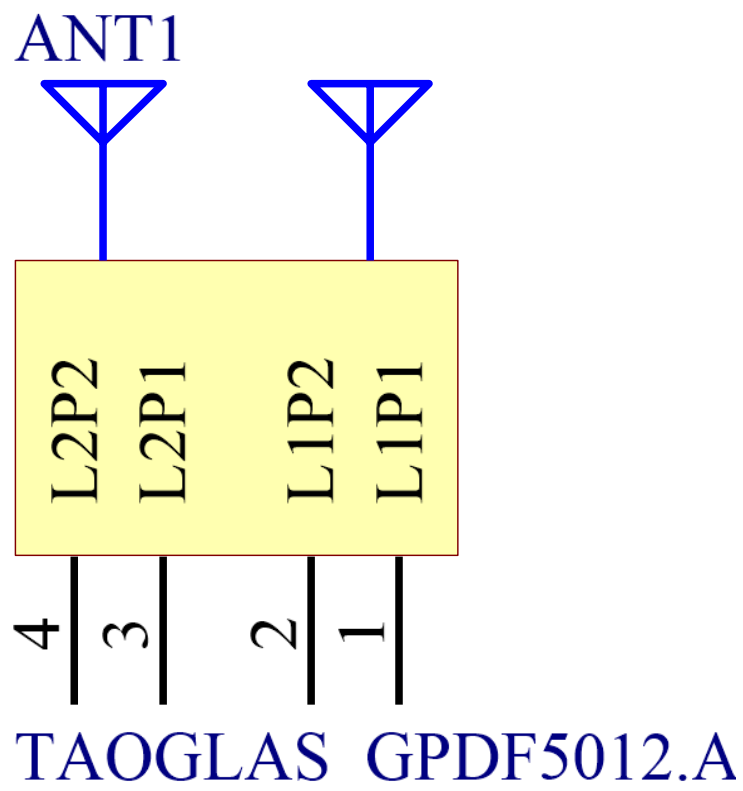

8.2 Antenna Integration

The antenna should be placed at the center of the PCB, in our integration we have used a 70mm X 70mm PCB evaluation board. Maintaining a symmetric ground plane shape and symmetric environment around the antenna is critical to maintaining the excellent axial ratio and phase center performance shown in this datasheet. The opposite side of the PCB from the antenna may be used for device electronics and does not need to maintain symmetry.

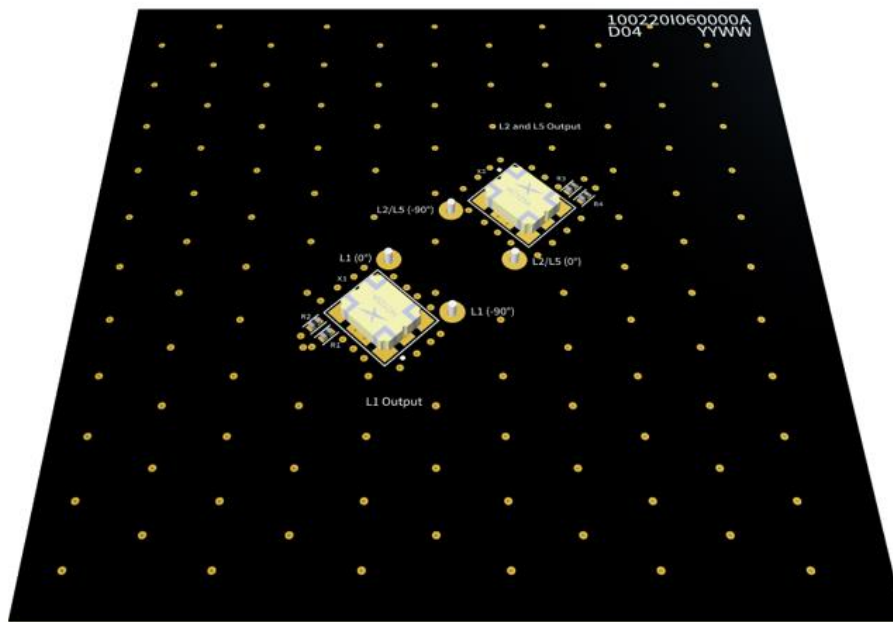

Bottom Side w/ Solder Mask

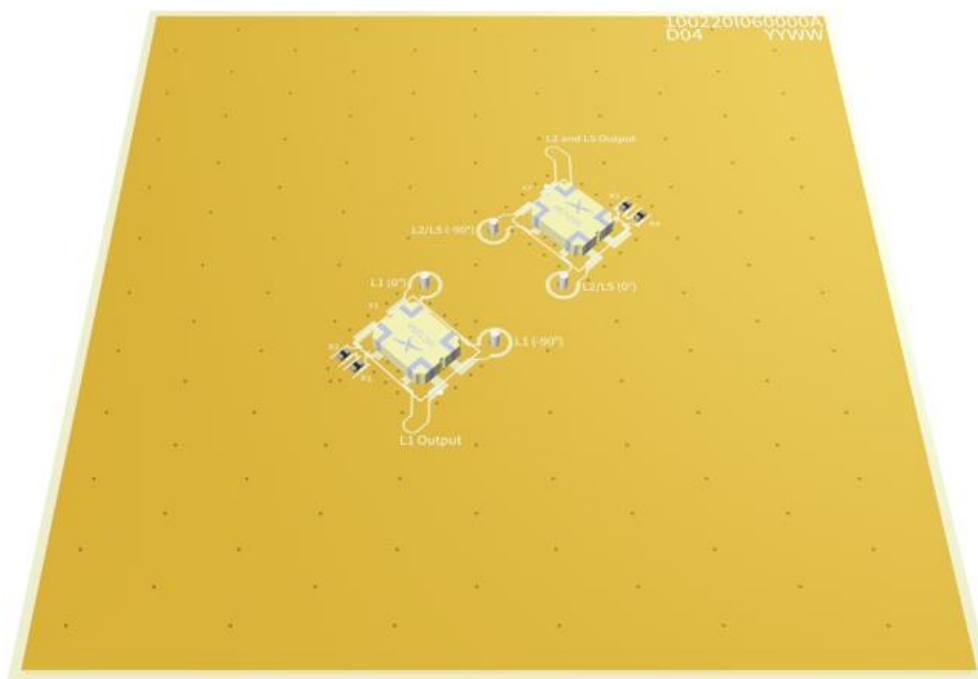

Bottom Side w/o Solder Mask

8.3 PCB Layout

The footprint and clearance on the PCB must comply with the antenna specification. The PCB layout shown in the diagram below demonstrates the antenna footprint.

Note that the hybrid couplers may be placed closer to the antenna pins. It is important that the trace length from the antenna pins are equal to their respected hybrid coupler. This is necessary to maintain the integrity of the phase in the signal.



Topside

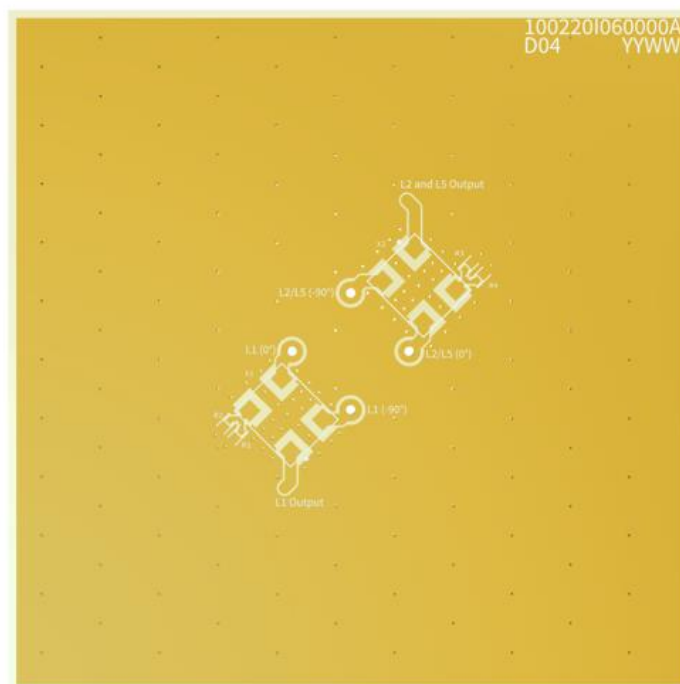

Bottom Side

8.4 Eval Board

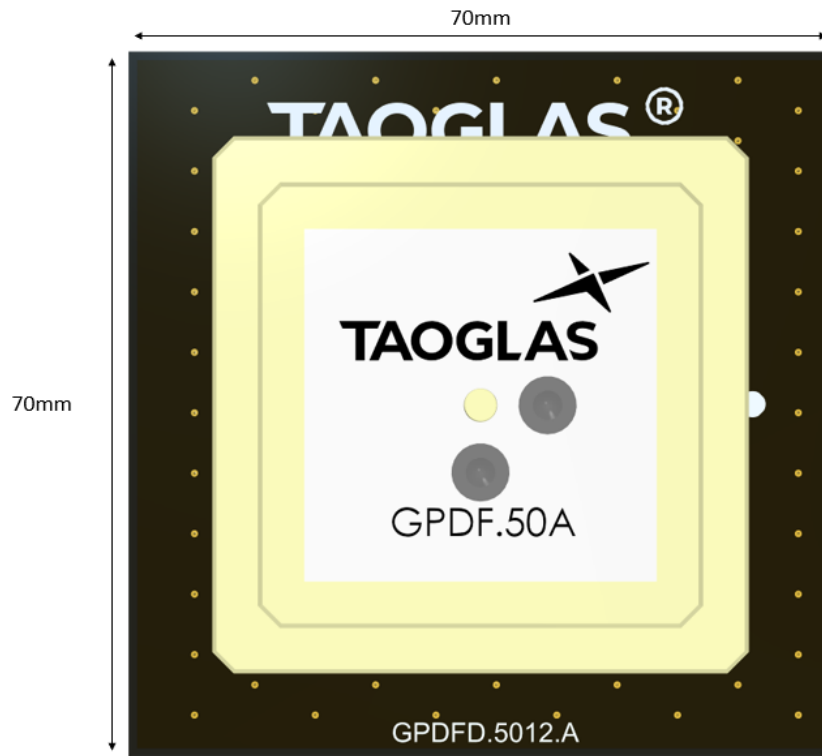

Topside

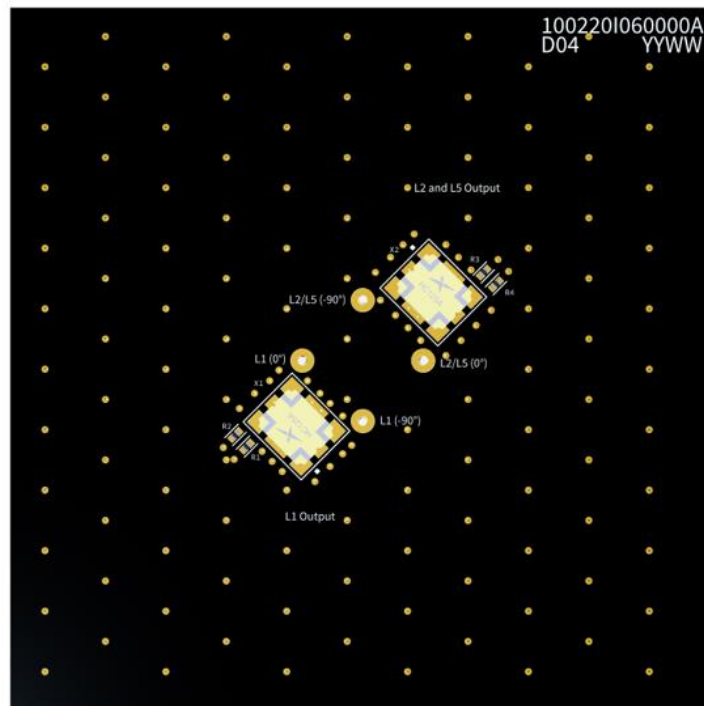

Bottom Side

8.5 Matching Circuit

Each patch element uses two orthogonal feeds that need to be combined in a hybrid coupler to ensure optimal axial ratio. Taoglas recommends our HC125.A, a high-performance hybrid coupler specifically engineered for use with our multi feed patches.

Two HC125.A's are required for this antenna, one for the high GNSS band of operation (1559-1610MHz) and another for the low GNSS band (1164MHz – 1300MHz). These hybrid couplers should be placed close to the antenna pins and terminated correctly using 2x 100ohm resistors in parallel.

The output of each of the hybrid couplers can feed into separate paths for high and low band GNSS filtering and amplification.

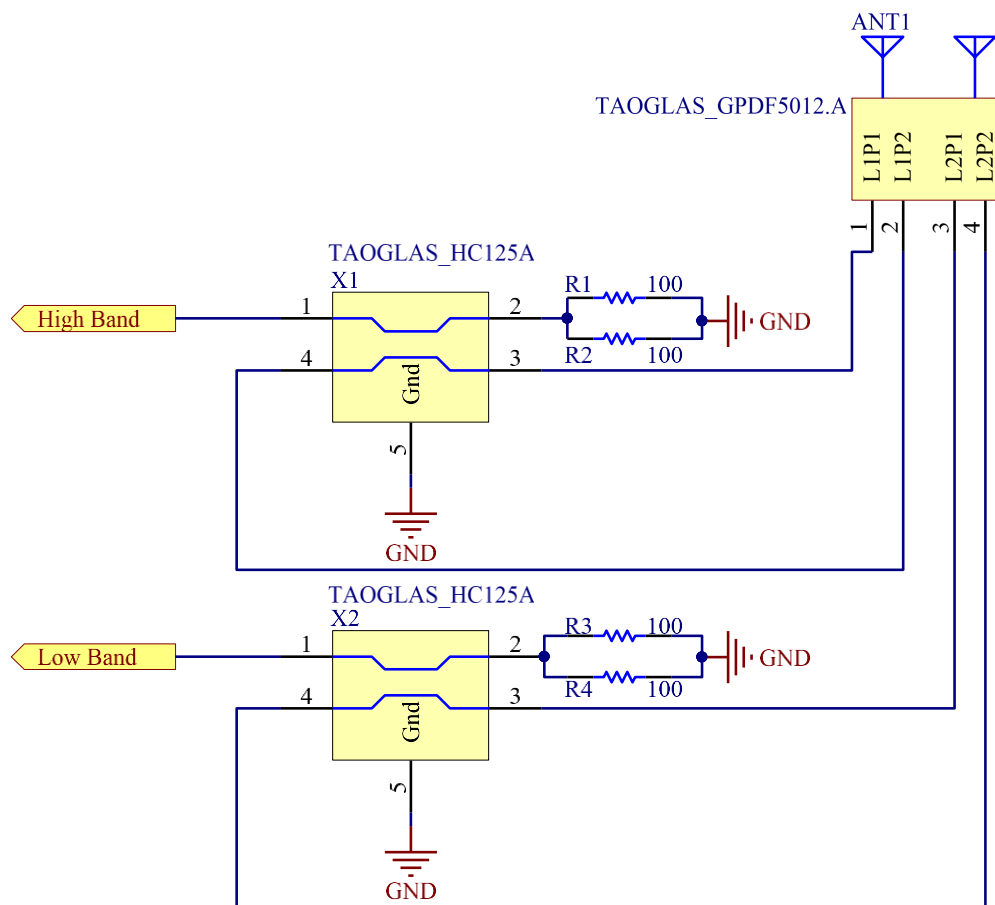

Designator	Type	Value	Manufacturer	Manufacturer Part Number
R1, R2, R3, R4	Resistor	100Ω (1%)	Vishay	CRCW0603100RFKEC

8.6 Footprint

TOPSIDE OF PCB

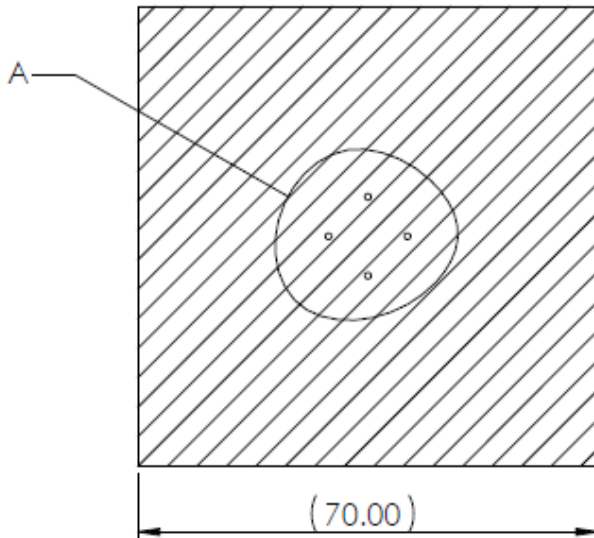

BOTTOM SIDE OF PCB

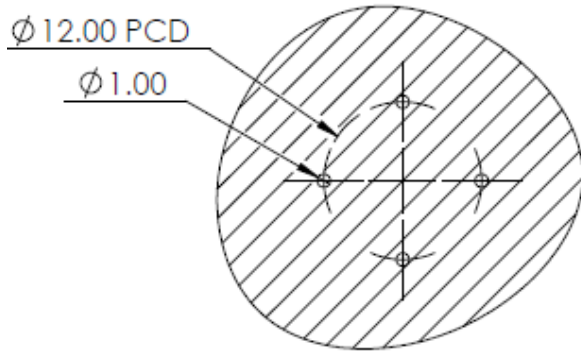
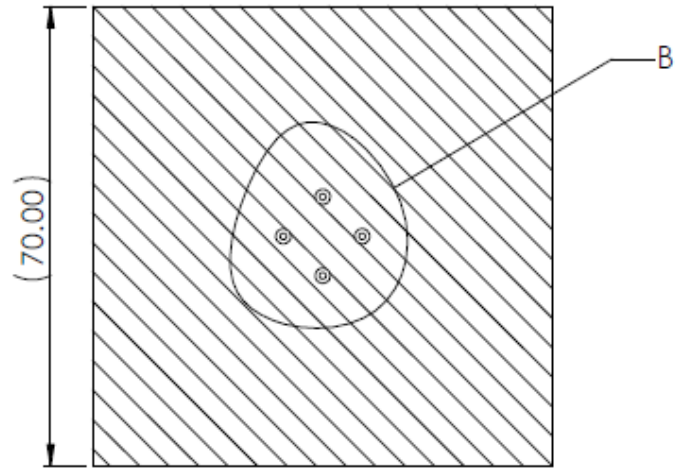

DETAIL A
SCALE 2:1

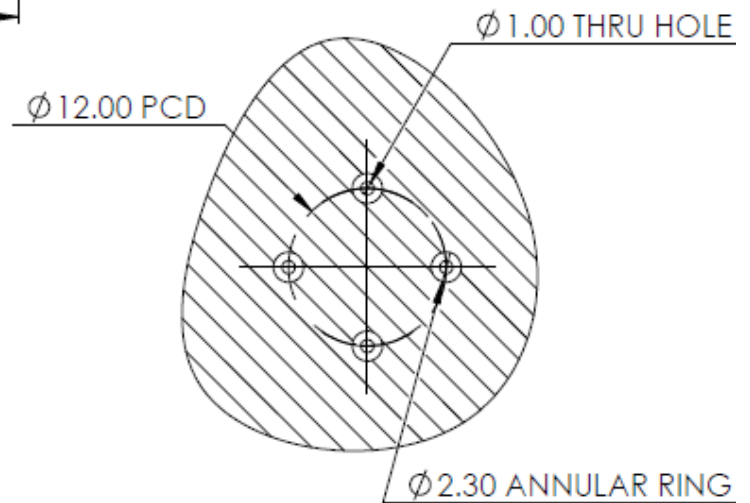

DETAIL B
SCALE 2:1

9. Packaging

8pcs GPDF5012.A per Tray
Weight: 690g

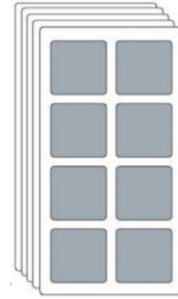

32pcs GPDF5012.A per Inner Carton
Dimensions: 263*154*96 mm
Weight: 3Kg

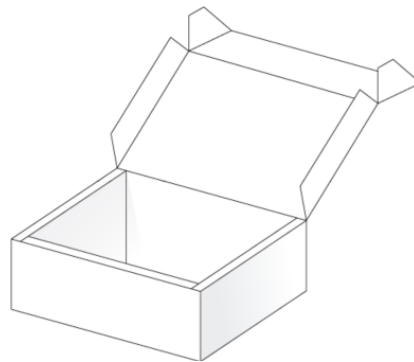

128pcs GPDF5012.A per Inner Carton
Dimensions: 327*280*218 mm
Weight: 12.5Kg

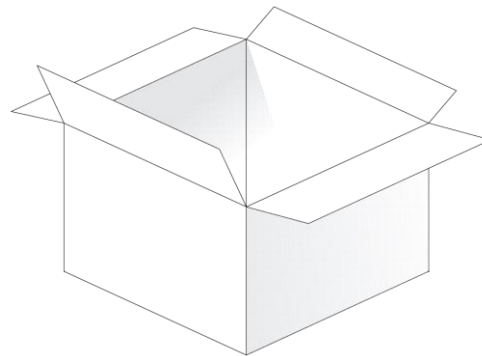

Changelog for the datasheet

SPE-20-8-103 – GPDF5012.A

Revision: E (Current Version)

Date:	2023-07-25
Notes:	Updated Antenna Field Testing
Author:	Gary West

Previous Revisions

Revision: D

Date:	2023-05-16
Notes:	Updated test data
Author:	Gary West

Revision: C

Date:	2022-01-11
Notes:	Added integration guide
Author:	Gary West

Revision: B

Date:	2022-01-11
Notes:	Added integration guide
Author:	Gary West

Revision: A (Original First Release)

Date:	2020-10-14
Notes:	Initial Release
Author:	Jack Conroy



www.taoglas.com

