

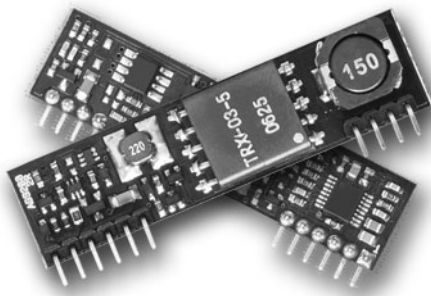

# Ag9200-S

## Power-Over-Ethernet Module



## 1 Features

- IEEE802.3af compliant
- Small SIL package size - 56mm (L) x 14mm (H)
- Low output ripple and noise
- Input voltage range 36V to 57V
- Minimal (low cost) external components required
- Overload and short-circuit protection
- Adjustable Output
- Higher efficiency DC/DC converter
- 1500V isolation (input to output)
- Silvertel "design-in" assistance

## 2 Description

The Ag9200 series of modules are designed to extract power from a conventional twisted pair Category 5 Ethernet cable, conforming to the IEEE 802.3af Power-over-Ethernet (PoE) standard.

The Ag9200 signature and control circuit provides the PoE compatibility signature and power classification required by the Power Sourcing Equipment (PSE) before applying up to 15W power to the port. The Ag9200 is compatible with Class 0 to Class 3 equipment.

The high efficiency DC/DC converter operates over a wide input voltage range and provides a regulated low ripple and low noise output. The DC/DC converter also has built-in overload and short-circuit output protection.

## Table of Contents

1	Features .....	1
2	Description.....	1
3	Ag9200 Product Selector.....	3
4	Pin Description .....	4
5	Functional Description .....	5
5.1	Inputs.....	5
5.2	PD Signature .....	5
5.3	Isolation .....	5
5.4	Power Classification .....	6
5.5	DC/DC Converter .....	7
5.6	Output Adjustment.....	7
5.7	Typical Connections .....	8
6	Typical Application.....	9
7	Typical Recommendations .....	10
8	Operating Temperature Range.....	10
9	Protection .....	12
10	Electrical Characteristics.....	13
10.1	Absolute Maximum Ratings <sup>1</sup> .....	13
10.2	Recommended Operating Conditions.....	13
10.3	DC Electrical Characteristics .....	13
11	Package .....	14
11.1	Ag9200 .....	14

## Table of Figures

Figure 1: Block Diagram .....	3
Figure 2: Ag9200 Package Format.....	4
Figure 3: Typical System Diagram.....	5
Figure 4: Class Programming Option.....	6
Figure 5: Output Adjustment .....	7
Figure 6: Typical Connection Diagram.....	8
Figure 7: Typical Application.....	9
Figure 8: Typical Layout.....	10
Figure 9: Power Plane Heatsink for Ag9200.....	11
Figure 10: Ag9203 Operating Profile .....	11
Figure 11: Ag9205 Operating Profile .....	12

### 3 Ag9200 Product Selector

Part Number†	Nominal Output Voltage	Maximum Output Power *	Marking
Ag9205-S	5.0V	13 Watts	5
Ag9203-S	3.3V	10 Watts	3

\*At 25°C with  $V_{IN} = 48V$

† The Ag9200 fully meets the requirements of the RoHS directive 2002/95/EC on the restriction of hazardous substances in electronic equipment.

**Table 1: Ordering Information**

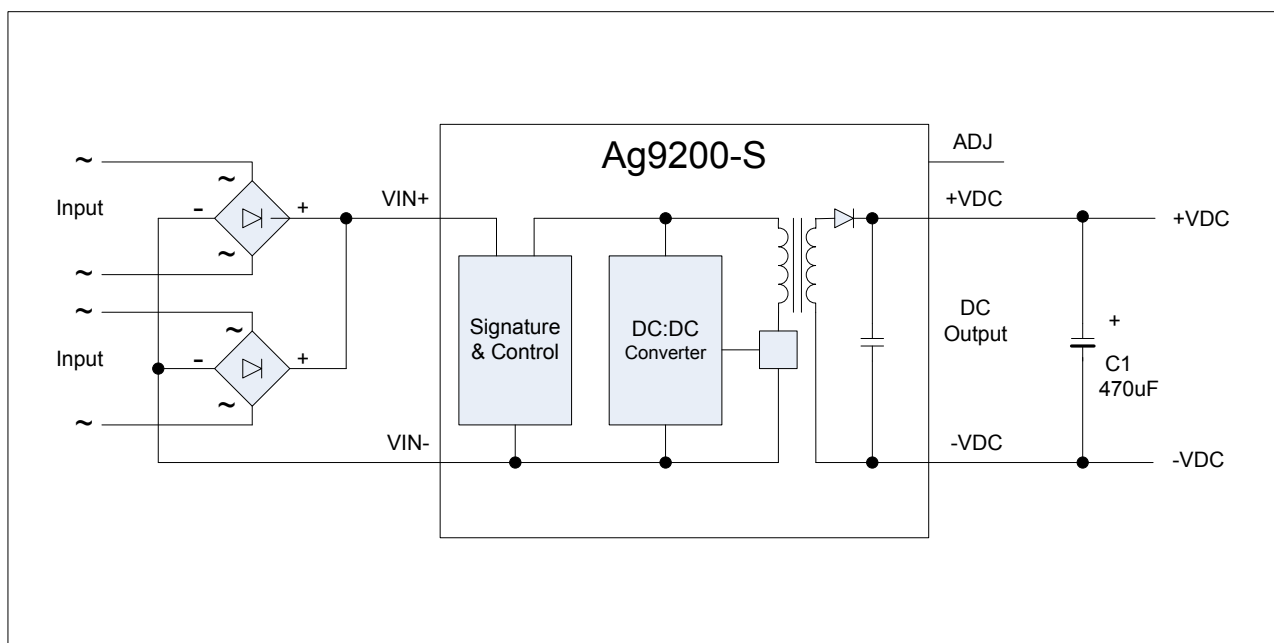

**Figure 1: Block Diagram**

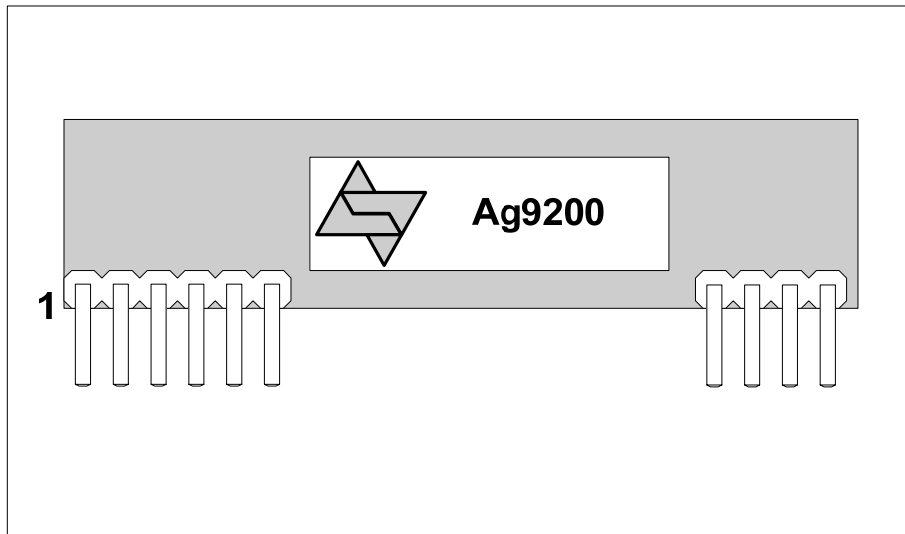

**Figure 2: Ag9200 Package Format**

## 4 Pin Description

Pin #	Name	Description
1	VIN+	<b>Direct Input +.</b> This pin connects to the positive (+) output of the input bridge rectifiers (internally connected to pin 3).
2	VIN-	<b>Direct Input -.</b> This pin connects to the negative (-) output of the input bridge rectifiers (internally connected to pins 4 and 5).
3	VIN+	<b>Direct Input +.</b> Internally connected to pin 1.
4	VIN-	<b>Direct Input -.</b> Internally connected to pin 2.
5		
6	CP	<b>Class Programming.</b> Connecting an external resistor to VIN- will change the current class of the module. With no resistor fitted the Ag9200 will default to Class 0.
7	-VDC	<b>Ground.</b> The ground return for the +VDC output.
8	+VDC	<b>DC Output.</b> This pin provides the regulated output from the DC/DC converter.
9	ADJ	<b>Output Adjust.</b> The output voltage can be adjusted from its nominal value, by connecting an external resistor from this pin to either the +VDC pin or the -VDC pin.
10	IC	<b>Internal Connection.</b> Do not connect to this pin.

## 5 Functional Description

### 5.1 Inputs

The Ag9200 is compatible with equipment that uses the different power options, see Figure 3: Typical System Diagram. It is specified that the PSE does not apply power to the both outputs at the same time (Refer to IEEE802.3af for more information).

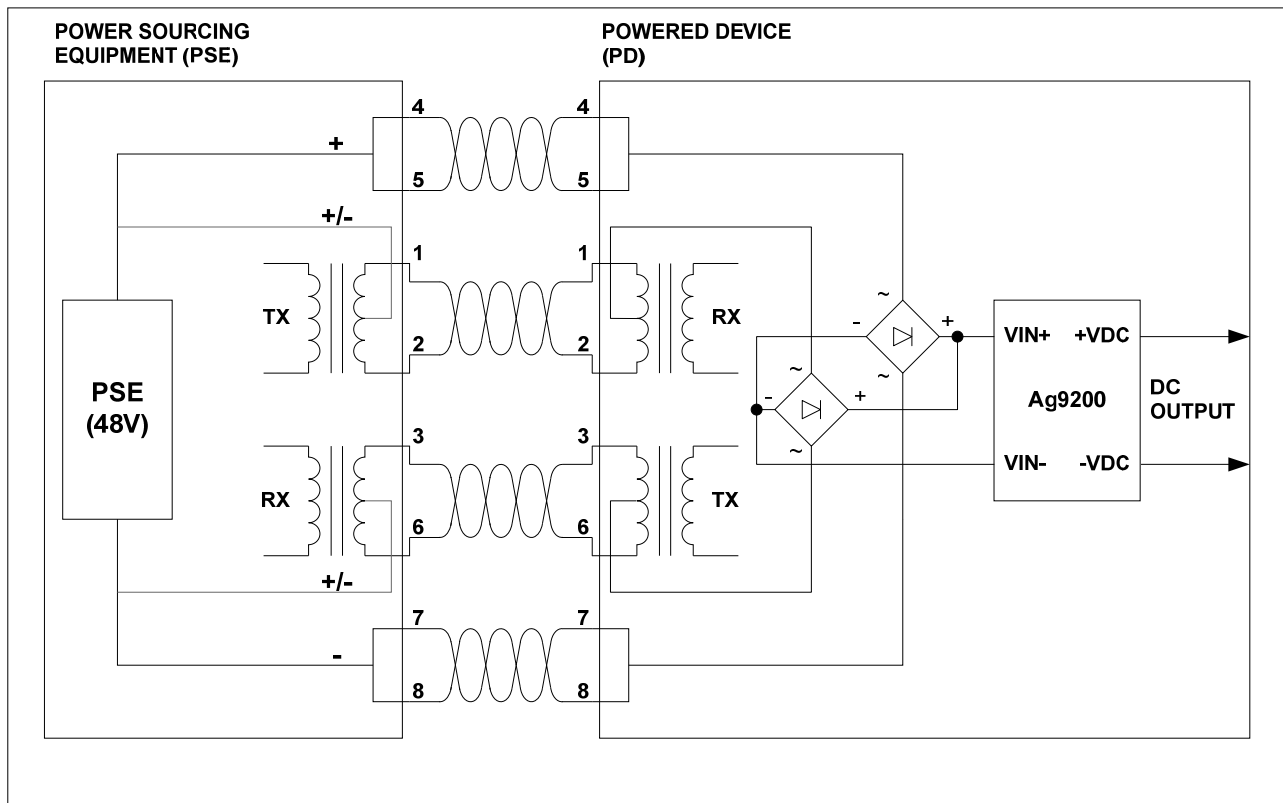

**Figure 3: Typical System Diagram**

### 5.2 PD Signature

When the Ag9200 is connected to the Cat 5e cable, it will automatically present a Powered Device (PD) signature to the Power Sourcing Equipment (PSE) or Midspan Equipment, when requested. The equipment will then recognise that a powered device is connected to that line and supply power.

### 5.3 Isolation

To meet the safety isolation requirements of IEEE802.3af section 33.4.1 a Powered Device (PD) must pass the electrical strength test of IEC 60950 sub clause 6.2. This calls for either a) 1000VAC test or b) 1500V impulse test. The Ag9200 is designed to meet b) 1500V impulse test. . It is also important that the tracks on either side of the isolation

barrier have at least a 3mm clearance, see Figures 8 & 9 and Section 11 for more information.

### 5.4 Power Classification

This is optional from the PSE and is used for power management. The Ag9200 allows the current class to be externally programmed by connecting a resistor between the CP and VIN- pins, see Figure 4: Class Programming Option. If no resistor is fitted the Ag9200 will default to Class 0, a full list of programming resistor values are shown in Table 2: Class Programming.

CLASS	Programming Resistance (Ohms)	Min Power (W)	Max Power (W)
0	Do not fit	0.44	12.95
1	698 $\pm$ 1%	0.44	3.84
2	383 $\pm$ 1%	3.84	6.49
3	249 $\pm$ 1%	6.49	12.95
4	TBD	Reserved	Reserved

**Table 2: Class Programming**

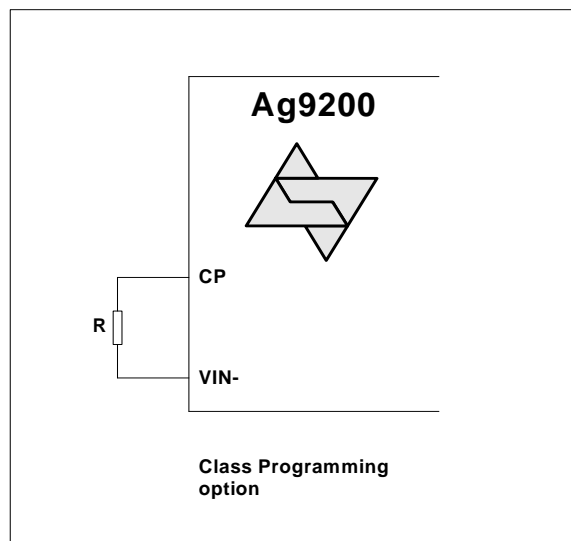

**Figure 4: Class Programming Option**

## 5.5 DC/DC Converter

The Ag9200's DC/DC converter provides a regulated low ripple and low noise output that has built-in overload and short-circuit output protection - see Table 1: Ordering Information for voltage and power ratings.

## 5.6 Output Adjustment

The Ag9200 has an ADJ pin, which allows the output voltage to be increased or decreased from its nominal value.

Figure 5: Output Adjustment shows how the ADJ pin is connected: -

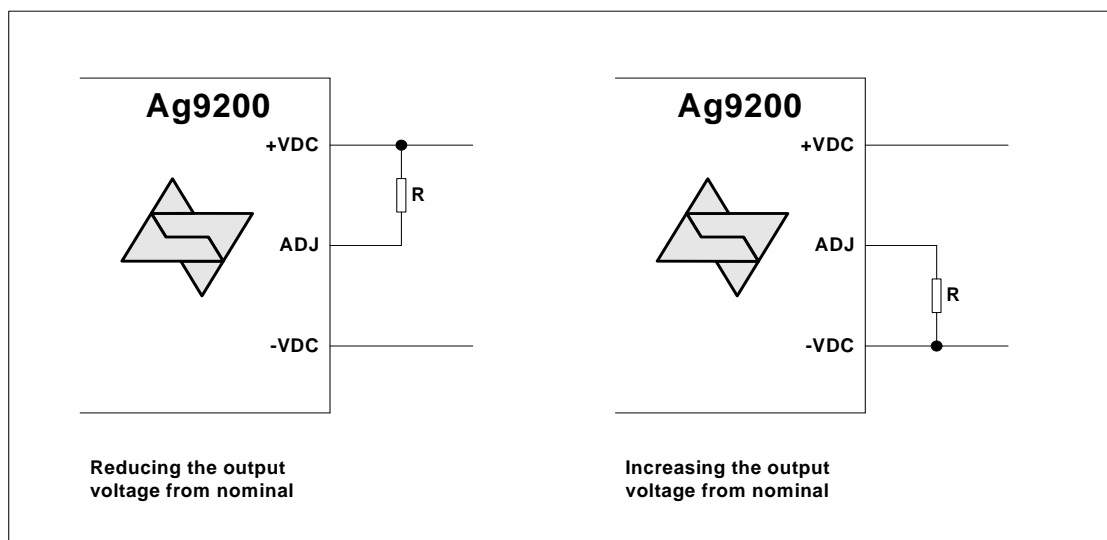

**Figure 5: Output Adjustment**

<b>Reducing the output voltage, connect R between ADJ and +VDC</b>		
Value of R	Ag9203 output	Ag9205 output
Open Circuit	3.30V	5.00V
0 Ohms	2.90V	4.50V
<b>Increasing the output voltage, connect R between ADJ and -VDC</b>		
Value of R	Ag9203 output	Ag9205 output
Open Circuit	3.30V	5.00V
0 Ohms	3.65V	5.65V

**Table 3: Output Adjustment Resistor (R) Value**

## 5.7 Typical Connections

Figure 6: Typical Connection Diagram, a minimum of 470 $\mu$ F is recommended.

The value of C1 will be related to the maximum load step change that the output needs to drive. For example, in an application where the output needs to cope with high load step changes, a minimum of 1000 $\mu$ F should be used. This can be a standard low cost electrolytic and does not need to be a low ESR type (ESR between 100m $\Omega$  to 350m $\Omega$ ).

Figure 6 shows a 16V capacitor that would cover all product variants up to and including the Ag9205, see Table 1: Ordering Information.

The Class programming and the Output Adjust inputs are optional and are provided to give great flexibility to the Ag9200 product range. Further information on using these inputs can be found in sections Power Classification and Output Adjustment.

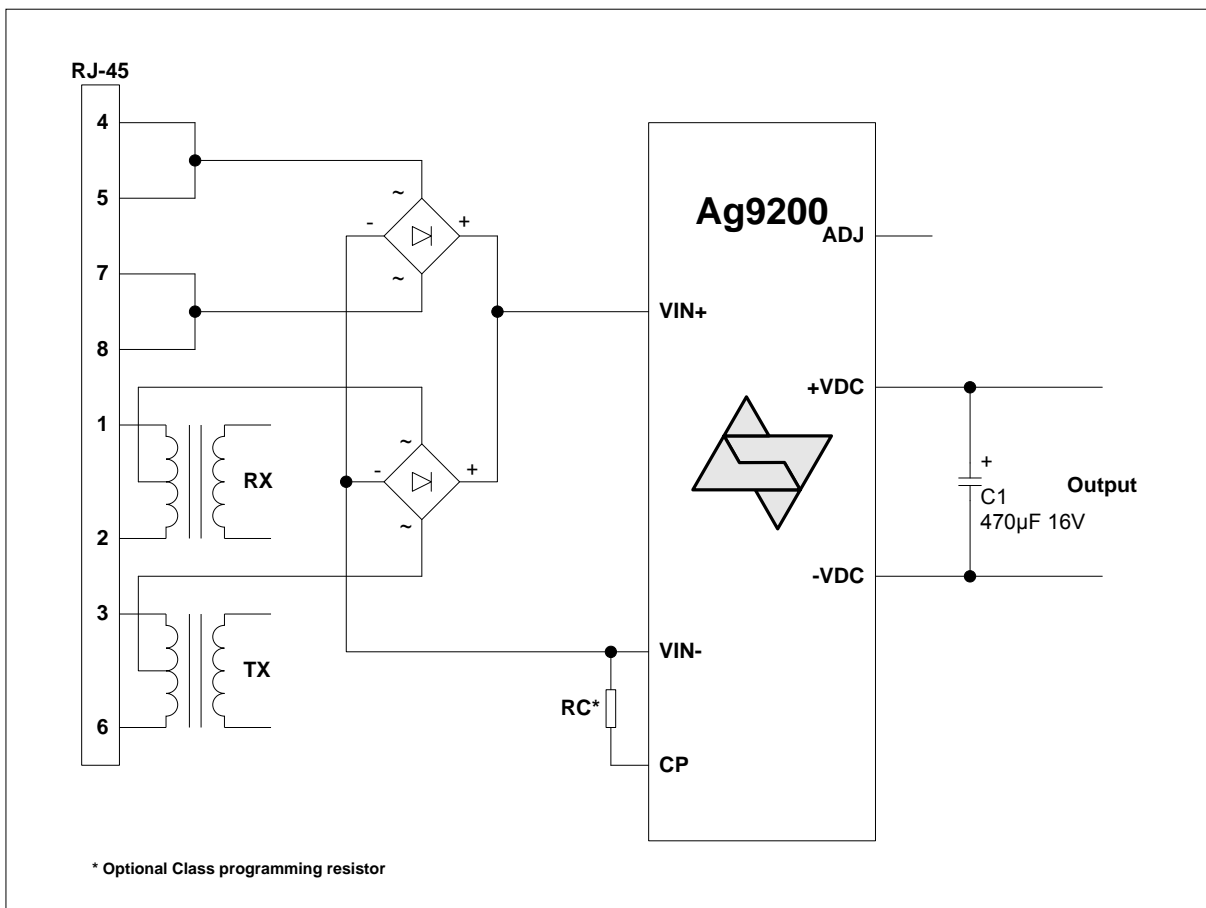

Figure 6: Typical Connection Diagram



## 6 Typical Application

The Ag9200 can be used in numerous applications, in the example shown in Figure 7: Typical Application, the data outputs from the switch are connected to the inputs of a midspan. The midspan will then add power (to the data) on each output that supports Power over Ethernet (PoE).

In this example port 1 is connected to an ethernet camera and port 2 is connected to a wireless access point, both of these devices have a built-in Ag9200. When the midspan is switched on (or when the device is connected), the midspan will check each output for a PoE signature. On ports 1 and 2 the Ag9200 will identify themselves as PoE enabled devices and the midspan will supply both data and power to these peripherals.

The other ports (shown in this example) will not have a PoE signature and the midspan will only pass the data through to these peripherals. The midspan will continuously monitor each output to see if a PoE enabled device has been added or removed.

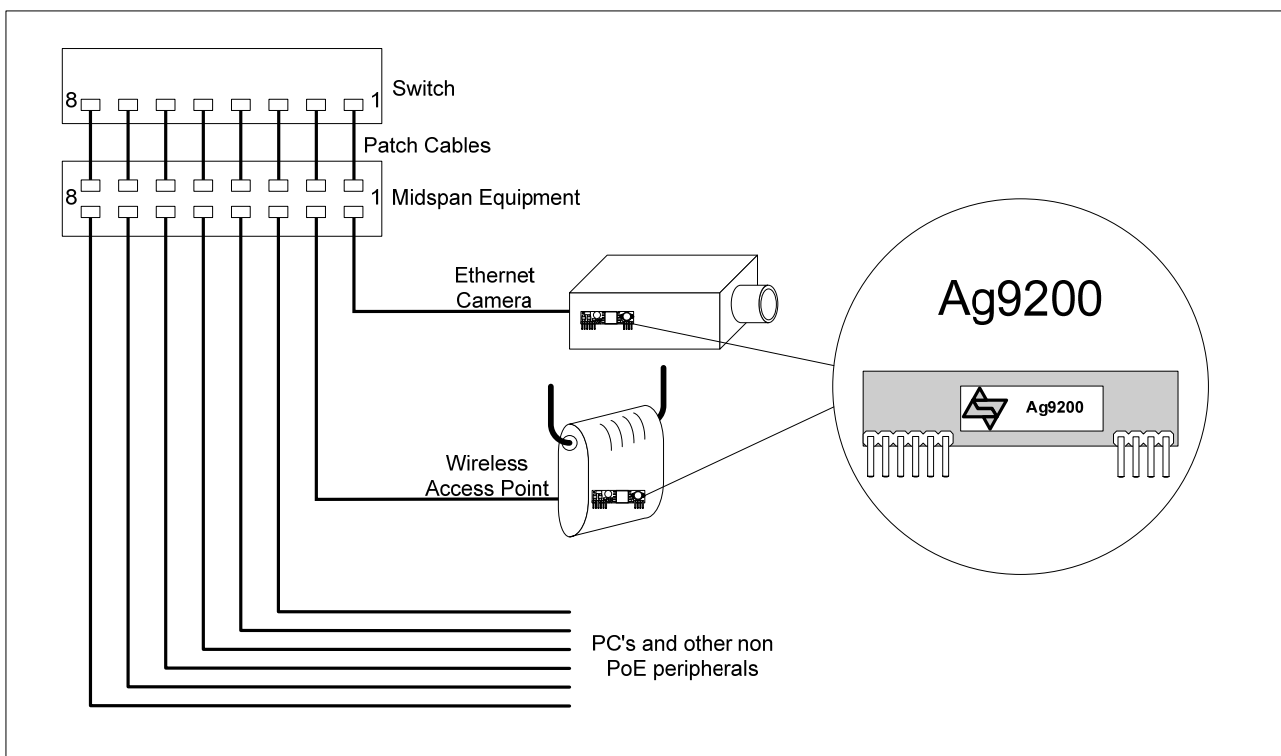

**Figure 7: Typical Application**

## 7 Typical Recommendations

Figure 8: Typical Layout gives an example of the tracking needed for the Ag9200. R1, R2 and R3 are optional components, The thermal performance of the Ag9200 can be improved by increasing the surface area of the output tracks (+VDC and -VDC). This is not applicable if the Ag9200 is in a socket.

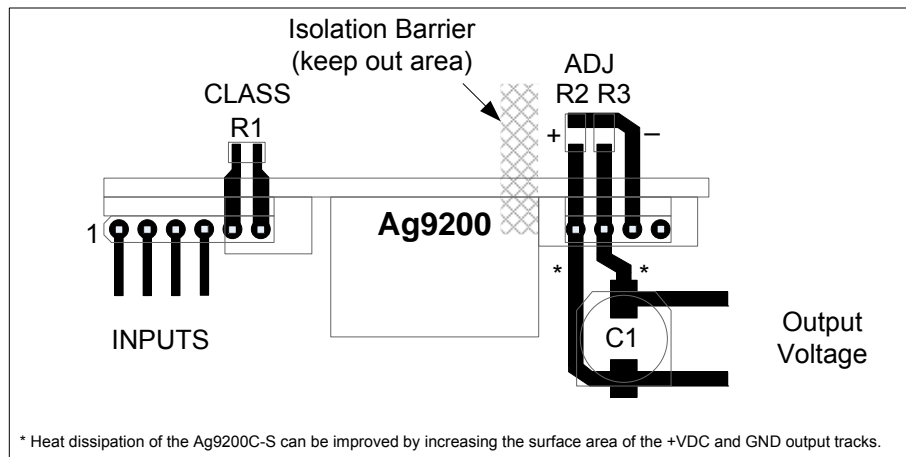

**Figure 8: Typical Layout**

## 8 Operating Temperature Range

Because the Ag9200 is a power component, it will generate heat, so it is important that this be taken into consideration at the design stage.

The heart of the Ag9200 is a DC/DC converter, which like any other power supply will generate heat. The amount of heat generated by the module will depend on the load it is required to drive and the input voltage supplied by the PSE. The information shown within this section of datasheet is referenced to a nominal 48Vdc input voltage supplied by the PSE.

The Ag9200 has a maximum ambient operating temperature of 70°C see Figure 10 & Figure 11. These results are in still air without any heatsinking, the performance of the Ag9200 can be improved by forcing the airflow over the part or by using a heatsink (see the Ag9200 application note on heatsinking for more information).

The output stage of the Ag9200 has a built-in thermal protection circuit, to prevent the module from being damaged if operated beyond its power / temperature specification.

Because each application is different it is impossible to give fixed and absolute thermal recommendations. However it is important that any enclosure used has sufficient ventilation for the Ag9200 and a direct airflow if possible.

One simple method for drawing some of the heat away from the Ag9200 is shown in Figure 9. Power planes connected to the +VDC and -VDC pins of the Ag9200 can be used to draw heat away from the DC/DC converter via the output pins.

These power planes must be on the outer layers of the PCB and the Ag9200 must not be fitted into a socket.

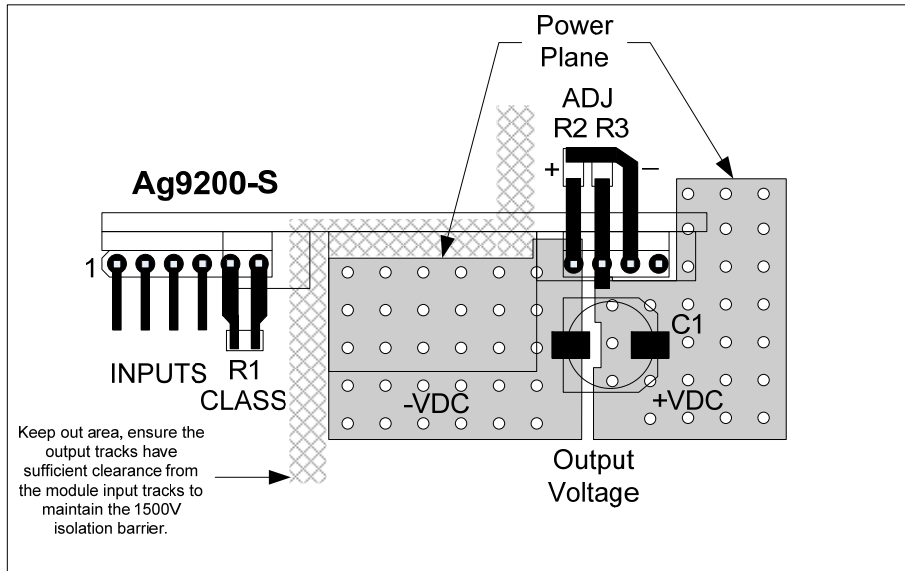

**Figure 9: Power Plane Heatsink for Ag9200**

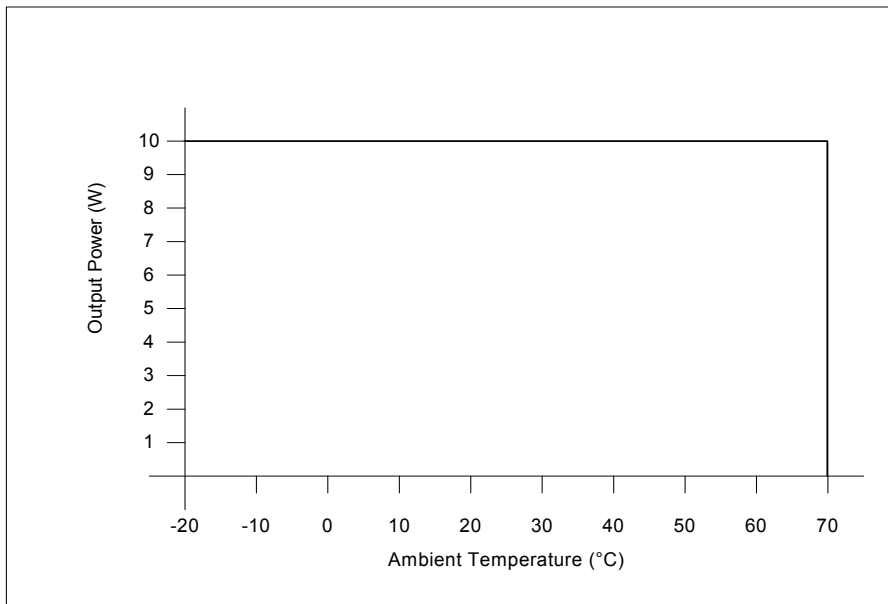

**Figure 10: Ag9200 Operating Profile**

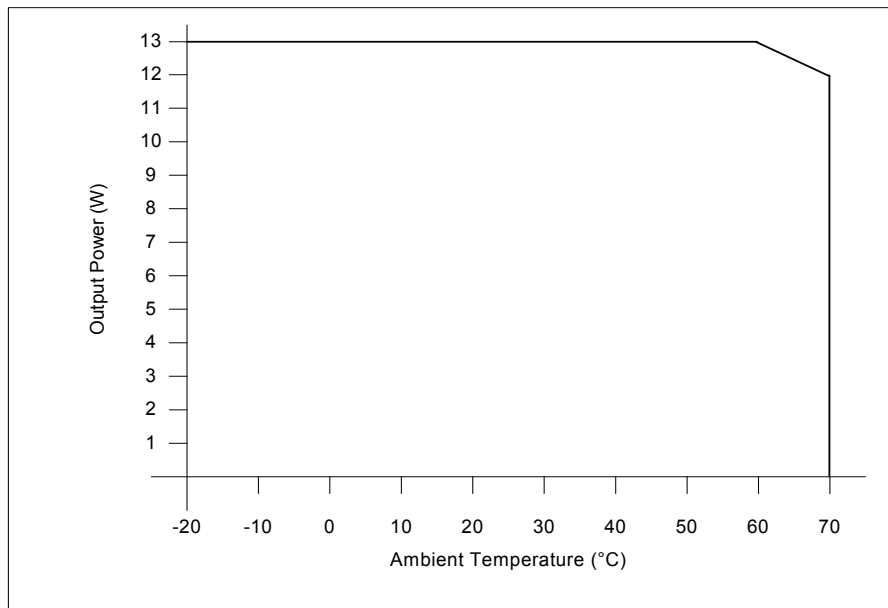

**Figure 11: Ag9205 Operating Profile**

## 9 Protection

The Ag9200 must be protected from over-voltages exceeding the 80V maximum rated surge input voltage. An inexpensive but effective solution can be achieved by connect Tranzorb diodes across each of the inputs; see Apps Note “ANX-POE-Protection”.

## 10 Electrical Characteristics

### 10.1 Absolute Maximum Ratings<sup>1</sup>

	Parameter	Symbol	Min	Max	Units
1	DC Supply Voltage	$V_{CC}$	-0.3	60	V
2	DC Supply Voltage Surge for 1ms	$V_{SURGE}$	-0.6	80	V
3	Storage Temperature	$T_S$	-40	+100	$^{\circ}C$

Note 1: Exceeding the above ratings may cause permanent damage to the product. Functional operation under these conditions is not implied. Maximum ratings assume free airflow.

### 10.2 Recommended Operating Conditions

	Parameter	Symbol	Min	Typ	Max	Units
1	Input Supply Voltage <sup>1</sup>	$V_{IN}$	36	48	57	V
2	Under Voltage Lockout	$V_{LOCK}$	30		36	V
3	Operating Temperature <sup>2</sup>	$T_{OP}$	-20	25	70	$T_a / ^{\circ}C$

Note 1: With minimum load

2: See Section Operating Temperature Range

### 10.3 DC Electrical Characteristics

	DC Characteristic	Sym	Min	Typ <sup>1</sup>	Max	Units	Test Comments
1	Nominal Output Voltage	+VDC	3.1	3.3	3.5	V	Ag9203
4.75			5	5.25	V	Ag9205	
2	Output Current ( $V_{IN} = 48V$ )	PWR			3.03	A	Ag9203
					2.6	A	Ag9205
3	Line Regulation	$V_{LINE}$		0.1		%	@ 50% Load
4	Load Regulation	$V_{LOAD}$		0.5		%	@ $V_{IN}=48V$
5	Output Ripple and Noise	$V_{RN}$		80		mVp-p	@ Max load <sup>2</sup>
6	Minimum Load	$R_{LOAD}$	100			mA	for specified regulation <sup>3</sup>
7	Short-Circuit Duration <sup>4</sup>	$T_{SC}$			$\infty$	sec	
8	Efficiency	EFF		88		%	Ag9205 @ 50% Load
9	Isolation Voltage (I/O)	$V_{ISO}$			1500	$V_{PK}$	Impulse Test
10	Temperature Coefficient	TC		0.02		%	Per $^{\circ}C$

Note 1: Typical figures are at 25 $^{\circ}C$  with a nominal 48V supply and are for design aid only. Not Guaranteed

2: The output ripple and noise can be reduced with an external filter, see application note.

3: Can be used with a minimum load of 20mA with reduced voltage regulation.

4: Continuous short circuit duration is applicable at 25 $^{\circ}C$  ambient temperature in free air. At higher temperatures or with restricted airflow (e.g. in a sealed enclosure) the duration will need to be limited to avoid overheating.

## 11 Package

### 11.1 Ag9200

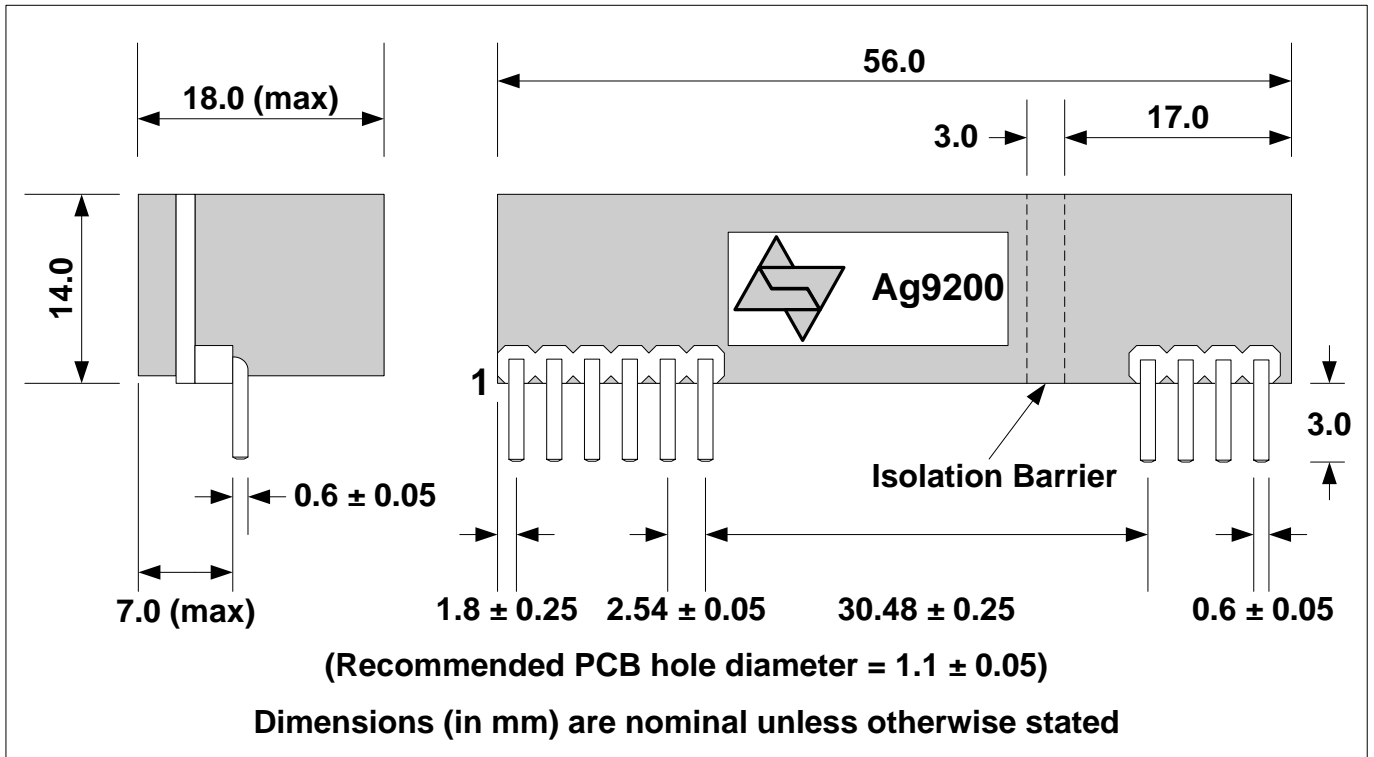

Information published in this datasheet is believed to be correct and accurate. Silver Telecom assumes no liability for errors which may occur or for liability otherwise arising out of use of this information or infringement of patents which may occur as a result of such use. No license is granted by this document under patents owned by Silver Telecom or licensed from third parties by Silver Telecom. The products, their specification and information appearing in this document are subject to change by Silver Telecom without notice.