

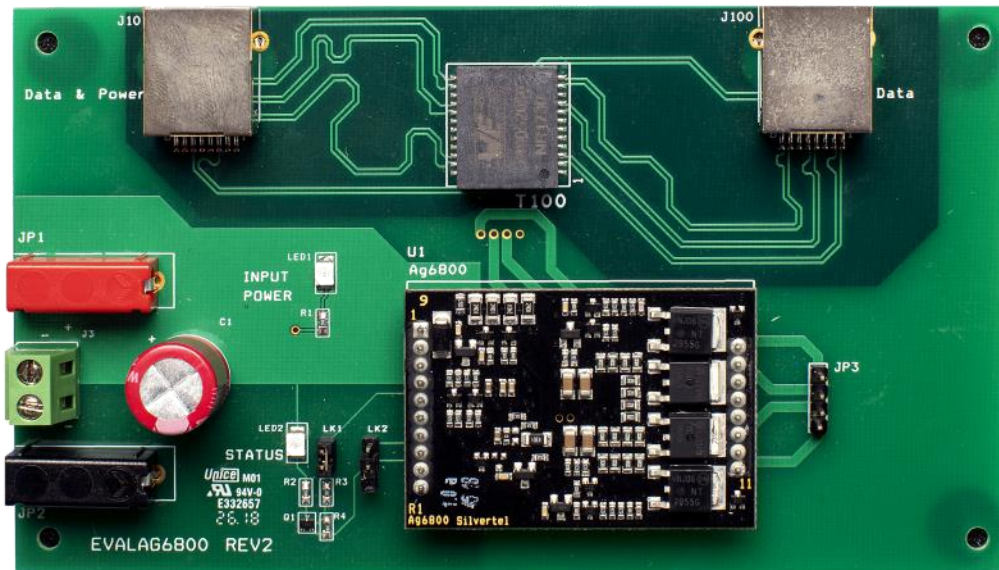

Evaluation Board User Manual



EvalAg6800 Evaluation Board User Manual

Version 1.1 – October 2022

Table of Contents

1	Introduction	3
2	Kit Contents.....	3
3	Board Layout.....	3
3.1	Link Settings	3
3.2	Input Output Connections.....	3
4	Input	4
4.1	Supply.....	4
4.2	Data Passthrough.....	4
4.3	PoH.....	4
5	LEDs.....	4
5.1	Power	4
5.2	Status	4
6	Output	5
7	Test Setup.....	5
8	Additional information.....	5
9	Schematic	6
10	Bill of Materials.....	7

Table of Figures

Figure 1: EvalAg7010 Board Layout.....	3
Figure 2: Basic Test Setup	5

1 Introduction

This Manual is a guide to using the EvalAg6800 evaluation board fitted with a Silvertel Ag6800 IEEE802.3bt compliant PSE module. The board is designed to pass through 10/100/1000/10GBASE-T Ethernet data rates in addition to power to an IEEE802.3 compliant PD device connected to J101.

2 Kit Contents

- EvalAg6800 Evaluation Board
- Ag6800 Module

3 Board Layout

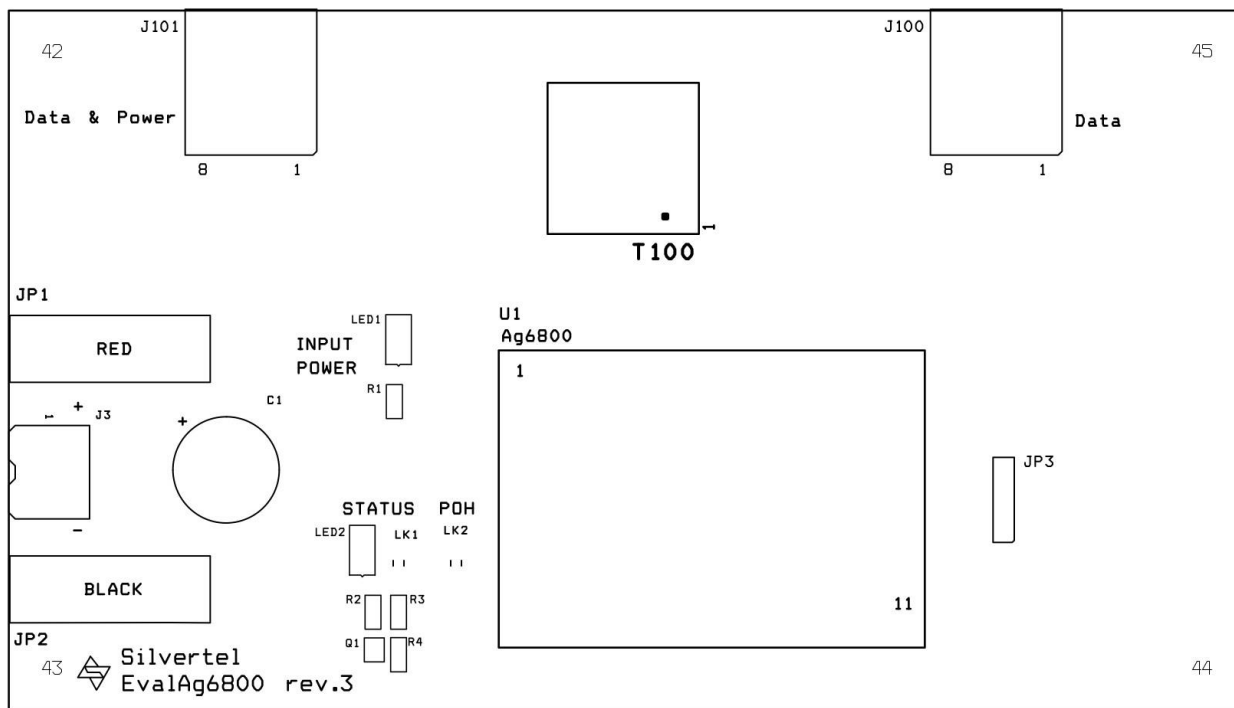

Figure 1: EvalAg7010 Board Layout

3.1 Link Settings

- LK1 – Status LED Enable
- LK2 – PoH enable

3.2 Input Output Connections

- J3 – Input Power DC jack
- JP1&JP2– Input Power Banana Connectors
- JP3 – Power Output link
- J100- – Data Passthrough
- J101 – Power and Data output

4 Input

4.1 Supply

The EvalAg6800 evaluation board can be powered using an isolated DC Power supply connected to either JP1 and JP2 via banana connectors, or with bare wire connections to J3

This supply should deliver between 52V-57V, a lower voltage will not cause damage to the module, but the module will not output if the supply voltage is too low.

It is recommended that the supply be capable of sourcing at least 3A to the Ag6800 to prevent the supply voltage dropping due to the inrush current of the connected PD.

4.2 Data Passthrough

Any data that is provided over the Data output port, J101 will be transposed along with the Power onto the PI (Ethernet cable) connected to the Data & Power port, J100 via the data transformer.

The data traces on the evaluation board have been designed to pass through 10/100/1000/10GBASE-T Ethernet data signals. No processing or amplification of this signal will be performed on the evaluation board.

4.3 PoH

If the powered device is to be a HDBaseT PoH or UPOE device, a jumper link should be connected to LK2 to enable the Ag6800 to provide full power to the Powered Device. This link should be open for all IEEE802.3 compliant PoE devices.

5 LEDs

5.1 Power

When voltage is supplied to the Evaluation board, LED1 will illuminate.

5.2 Status

The Status output pin is a low drive logic output and is connected to an LED drive circuit connected across the input rail. This can be disabled by removing the link LK1.

The LED will illuminate as per Table 1 once an IEEE compliant PD has been connected and powered.

Condition	Status Pulses (200ms)
No valid PD Detected	Off
PD Powered	On
Short Circuit Detected	1 x 200ms Pulse
Over Current Event Detected	2 x 200ms Pulse
Current Imbalance Detected	2 x 200ms Pulse
Input Voltage dropped below 47V	4 x 200ms Pulse

Table 1: Status LED

6 Output

To ensure that the Ag6800 does not apply power to a non-PoE enabled device the output port first checks for a valid PoE signature. If the Ag6800 does not detect a valid signature it will disconnect, wait approximately 2 seconds before trying again.

Once a valid signature has been detected the Ag6800 will then perform classification to determine the power requirement of the PD, only after this has occurred will the Ag6800 supply power to the powered device.

JP3 is a direct tap into the pairset power, this can be used to perform monitoring or If the output of the Ag6800 is to be connected into an application circuit, a jumper cable can be used to inject the output of the Ag6800 into the application circuit without having to pass through the RJ45 or data transformer.

7 Test Setup

Figure 2 shows the basic set up using the EvalAg6800 evaluation board powered by a DC power supply with an output between 52V and 57V. The powered device and data source do not need to be connected before power is applied.

The equipment required: -

- Power supply unit, +52-57V output e.g. 60V bench power supply
- Powered device
- CAT5e/CAT6a cables

Optional equipment: -

- Data source e.g. PC

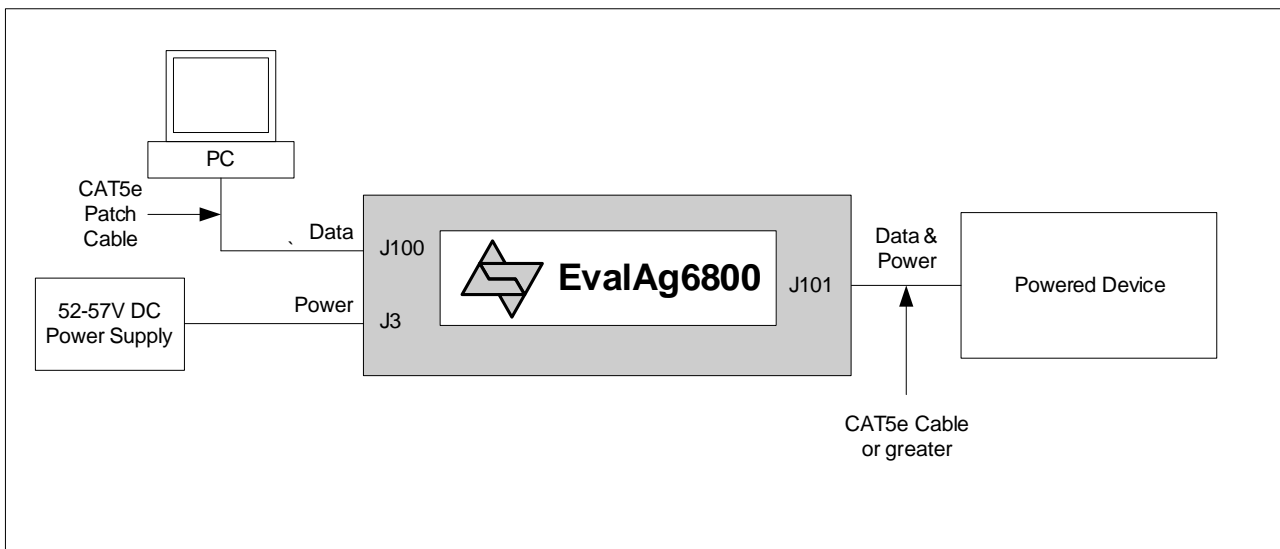
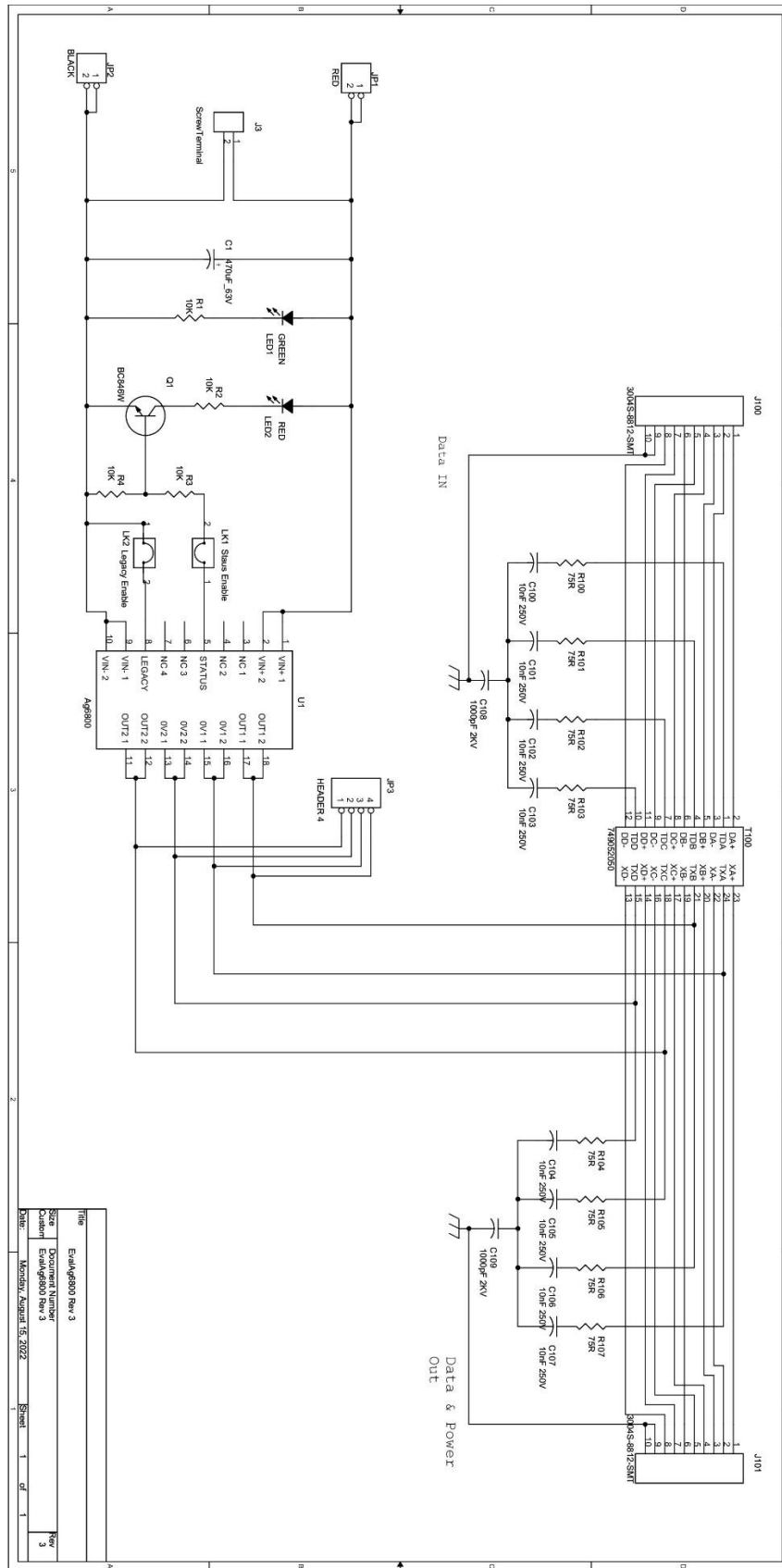

Figure 2: Basic Test Setup

8 Additional information

Full operating conditions and feature set can be found in the Ag6800 product datasheet, available from www.silvertel.com.

9 Schematic



10 Bill of Materials

Silver Part No.	Description	Value	Location:	Qty:	Package:	Rating:	Tol:	Supplier Pt NO:	Comments:
	PSE Module	Ag6800	U1	1	Custom	-	-	Silver Telecom Part	
	Transformer - Data	10G BaseT PoE+	J100	1	SMT	-	-	Wurth - 749052050	10 Way & 8 way socket
	SMD LED	RED LED	LED1, LED2	2	SMT	-	-	Wurth - 150 141 RS7 310 0	
	NPN Transistor	BC946BW	Q1	1	SOT323	60V	-		
	Capacitor Electrolytic	470uF	C1	1	Through Hole	63V	20%	Samsung NIC, TDK, Murata, Kemet, AVX & Wurth-860020778021	
	Ceramic multi-layer	10nF	C100 - C107	8	0805	63V	20%	Samsung NIC, TDK, Murata, Kemet, AVX & Wurth-885342207010	
	Ceramic multi-layer	1000uF 2KV	C108, C109	2	1206	2KV	20%	Samsung NIC, TDK, Murata, Kemet & AVX, Wurth-885342208024	
	Resistor - 0603	10K	R1, R2, R3, R4	4	0803	63mW	1%	Royal Ohm, Eurohm & Yageo	
	Resistor - 0905	75R	R100 - R107	8	0805	125mW	1%	Hirschmann, 973582100	
	Red Connector	4mm PCB Socket	JP1	1	Through Hole	-	-	Hirschmann, 973582101	
	Black Connector	4mm PCB Socket	JP2	1	Through Hole	-	-	Hirschmann, 973582101	
	0.1" header	4way (NO FIT)	JP3	0	Through Hole	-	-	Toby LHGS-04S-R-060-034, Wurth 6130041121	
	DC Power Connector	2 WAY SCREW TERMINAL	J3	1	Through Hole	-	-	Multicomp Pro MC000034, Wurth 691216510002S	
	Ethernet Connector	RJ45	J100, J101	2	SMT	-	-	Toby 3004S-8821-SMT	
	Link	2 Way	LK1, LK2	2	Through Hole	-	-	Toby LHGS-02S-R-060-034, Wurth 61300211121	
	Link	4 Way	JP3	1	Through Hole	-	-	Toby LHGS-04S-R-060-034, Wurth 6130041121	
	Module Socket	10 Way	U1a	1	Through Hole	-	-	Toby SLW-110-01-G-S	
	PCB	8 Way	U1b	1	Through Hole	-	-	Toby SLW-108-01-G-S	
	Jumpers Links	Rev 2R - 83.82mm x 146.56mm		1	-	-	-		
	Feet	Links		2	-	-	-		
	Feet	Sticky Feet		4	-	-	-	Atix RF-022	
			Total	39					

EvalAg6800 Eval Board - Rev.3

Date: 30th September, 2022